

SPECIFICATION SHEET

ARTISAN STONE DECK OVEN

MODELS: 4T2

Meet the oven that does it all. The Doyon 4T2 Series Artisan Stone Deck Oven gives bakers total command—zero convection, full temperature control, and customizable deck heights that adapt to any product you throw at it. Bake crackling hearth loaves, feather-light pastries, or a blistered 600°F pizza in minutes. Each chamber features its own steam tank, letting you dial in the exact crust and chew you want from the very first bake. This compact powerhouse delivers artisan quality without demanding artisan space.

- **High-Capacity Independent Steam Tank:** Generates a powerful, continuous volume of steam—essential for achieving the perfect artisanal crust and rise on yeast breads.
- **Ergonomic Advanced Digital Controls:** Positioned at eye level for effortless operation, this intuitive interface optimizes energy efficiency while allowing you to fine-tune the precise parameters of every bake.
- **Effortless Flip-Up Door:** Engineered for seamless, single-handed operation, allowing you to open or close the unit smoothly even when your hands are full.
- **Dual-Zone Independent Element Control:** Enjoy precision temperature calibration above and below your product. This advanced system dynamically compensates for heat loss during loading and unloading to ensure perfectly consistent bakes.
- **Manual Steam Release Vent:** Instantly expels excess moisture for rapid cavity recovery after your initial steam blast. This crucial step ensures uniform browning and helps achieve that coveted, perfectly blistered crust.
- **Double Deck Design. Maximize the output:** Eliminate installation headaches with a simple, single-point utility connection for electric, water, and drain. Engineered for ultimate space efficiency, this double deck design delivers the largest capacity-to-depth ratio on the market, holding three full-size or six half-size sheet pans per deck. Complete with a 3/4-inch-thick NSF-approved baking stone, you get authentic, direct-on-the-stone artisan results—and triple the production—without giving up precious kitchen space.



This appliance is intended to be used for commercial applications, for example, in kitchens of restaurants, canteens, hospitals and in commercial enterprises such as bakeries, butcheries, etc., but not for continuous mass production of food.



Project	
Item No.	
Notes	
Model Number	4T2

FEATURES & BENEFITS

<input type="checkbox"/> EYE LEVEL DIGITAL CONTROL	<input type="checkbox"/> 99 HOUR DELAY START TIMER & ECO MODE FOR SAVING MONEY BETWEEN BAKES
<input type="checkbox"/> INDEPENDENT STEAM TANK WITH CONTROL OF INJECTION (UP TO 4 SECONDS)	<input type="checkbox"/> BAKING TEMPERATURE UP TO 600°F
<input type="checkbox"/> CHAMBERS INTERIOR HEIGHT AVAILABLE IN 6", 8", 10", & 12"	<input type="checkbox"/> HOLDS (4) 18"X26" FULL SIZE OR (8) 13"X18" SHEET PANS
<input type="checkbox"/> INCLUDES (4) HEAVY DUTY S/S LEGS WITH HEAVY DUTY CASTERS	<input type="checkbox"/> INDEPENDENT ELEMENT CONTROL IN UPPER CHAMBER, LOWER STONE, AND COMPENSTION AROUND THE CHAMBER ENTRY POINT
<input type="checkbox"/> DESIGNED WITH A SINGLE ELECTRICAL CONNECTION, SINGLE DRAIN CONNECTION & SINGLE WATER LINE CONNECTION	

OPTIONS & ACCESSORIES

<input type="checkbox"/> MANUAL LOAF LOADER (LL4T)
<input type="checkbox"/> CLEANING BRUSH (MPA085)
<input type="checkbox"/> WATER FILTER (50-1530)
<input type="checkbox"/> REPLACEMENT CARTRIDGE (50-1531)
<input type="checkbox"/> STEEL DECK IN LIEU OF STONE
<input type="checkbox"/> EUROPEAN STYLE PROOFER (ES4T)
<input type="checkbox"/> SINGLE PHASE ELECTRICAL
<input type="checkbox"/> INTERNATIONAL ELECTRICAL (SEE BACK)

CONSTRUCTION

<input type="checkbox"/> FULL STAINLESS STEEL CONSTRUCTION
<input type="checkbox"/> SINGLE 1/2" WATER LINE CONNECTION
<input type="checkbox"/> ASSEMBLED FOR QUICK INSTALLATION
<input type="checkbox"/> 1/2" DRAIN LINE OUT REAR OF UNIT
<input type="checkbox"/> 3/4" THICK NSF APPROVED STONE INTERIOR PERFECT FOR TRUE HEARTH STYLE

CLEARANCES

6" (482 mm) on Top
1" (25 mm) around Sides
1" (76 mm) along Rear

INSTALLATION NOTES & REQUIREMENTS

Oven must be installed with proper ventilation in accordance with the local building code. Doyon does not recommend direct venting this oven. Prior to operation a water filter system must be installed.

INTERIOR CHAMBER HEIGHT

Doyon offers four different choices for interior chamber height. To help match up the best selection. Here is the optimal product for each height.

- 6" - Cookies, Cakes, Pies, Focaccia, Pizza, Cupcakes, Muffins, Cheesecakes
- 8" - Yorkshire Puddings/Popovers, Muffins, Bagels, Croissants, Scones, Focaccia, Angel Food Cake, Stollen
- 10" - Medium to Large Loaf of Bread (18 oz/ 500 Grams to 35 oz/1kg), Panettone
- 12" - Breads more then 35oz/1kg, Larger Protein Roasting & etc.

CONSULTANT SPECIFICATION

DOYON ARTISAN STONE DECK OVEN, ELECTRIC, FULLY INSULATED, STAINLESS STEEL CONSTRUCTION, PROGRAMMABLE TOUCHSCREEN CONTROL, STEAM INJECTION (INDEPENDENT TANK PER DECK), SINGLE WATER LINE CONNECTION, SINGLE DRAIN CONNECTION, SINGLE ELECTRICAL CONNECTION, AVAILABLE IN 6"/8"/10"/12" INTERIOR CHAMBER HEIGHTS, TWO DECKS EACH WITH 3/4" THICK NSF APPROVED STONE INTERIOR, ADJUSTABLE TEMPERATURE CONTROL IN UPPER PORTION OF CHAMBER/LOWER PORTION OF CHAMBER/DOOR COMPENSATION, ONE YEAR LABOR & TWO YEAR LIMITED PARTS WARRANTY, ETL, NSF, CE

WARRANTY

1 YEAR LABOR & 2 YEAR PARTS LIMITED WARRANTY

SPECIFICATIONS SUBJECT TO CHANGE WITHOUT NOTICE FOR PRODUCT IMPROVEMENT AND INNOVATION

KCL & REVIT DRAWINGS UPON REQUEST

REVISION 06/06/2026

DOYON BAKING

5600 13TH STREET, MENOMINEE, MI 49858

906.863.4401 | 800.338.9886

WWW.DOYONBAKING.COM



Project	
Item No.	
Notes	
Model Number	4T2

CONFIGURATIONS

Model	Inlet Size	Volts	Phase	Amps	kW	Hertz
4T2	Drain - 1/2" Inlet - 1/2"	208	1	90	18.6	50/60
		220	1	86	18.6	50/60
		230	1	82	18.6	50/60
		240	1	78	18.6	50/60
		208	3	56	18.6	50/60
		220	3	52	18.6	50/60
		230	3	52	18.6	50/60
		240	3	48	18.6	50/60
		380/415	3	28	18.6	50/60
		480	3	24	18.6	50/60

DRAWINGS

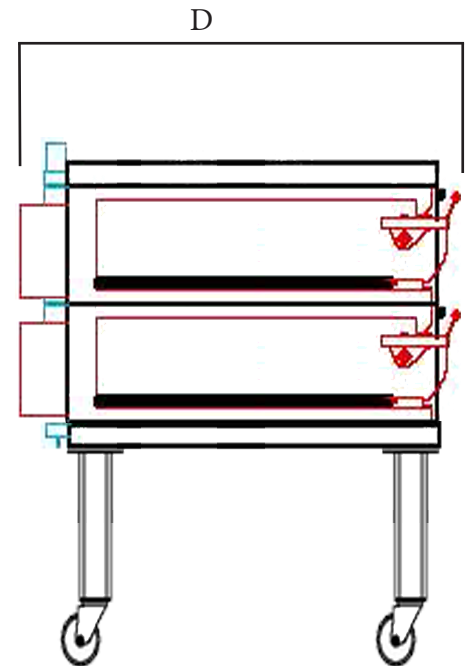
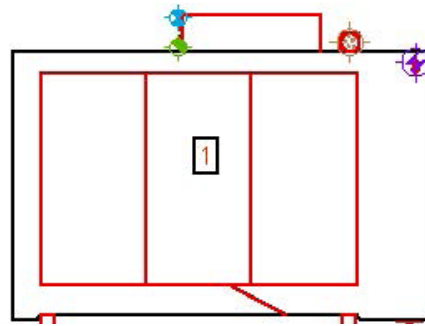
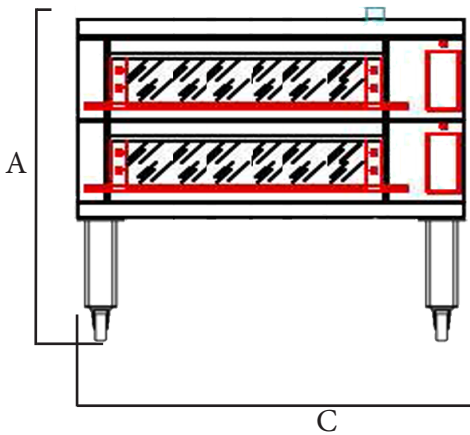

B
 Ext. Height (A) - 56.25" (1429 mm)
 Ext. Width (C) - 73" (1854 mm)
 Ext. Depth (D) - 57.12" (1451 mm)
 Int. Chamber Width - 56" (1420 mm)
 Int. Chamber Depth - 37.33" (949 mm)

- **Add 2" Additional to Height When Switching out the Deck (per) for 8" Interior Height, ,
- **Add 4" Additional to Height When Switching Out the Deck (per) for 10" Interior Height
- **Add 6" Additional to Height When Switching Out Deck (Per) for 12" Interior Chamber

Due to periodic changes in designs, methods, procedures, policies and regulations, the specifications contained in this sheet are subject to change without notice. While Doyon exercises good faith efforts to provide information that is accurate, we are not responsible for errors or omissions in information provided or conclusions reached as a result of using these specifications. By using the information provided, the user assumes all risks in connection with such use.

SPECIFICATIONS SUBJECT TO CHANGE WITHOUT NOTICE FOR PRODUCT IMPROVEMENT AND INNOVATION	DOYON BAKING
KCL & REVIT DRAWINGS UPON REQUEST	5600 13TH STREET, MENOMINEE, MI 49858
REVISION 06/06/2026	906.863.4401 800.338.9886
	WWW.DOYONBAKING.COM