



Project \_\_\_\_\_  
 AIA # \_\_\_\_\_ SIS # \_\_\_\_\_  
 Item # \_\_\_\_\_ Quantity \_\_\_\_\_ C.S.I. Section 114000



DEALERS CHOICE G-SERIES

## G-SERIES

### 1-Section Refrigerator Pass-Thru Self-Contained Solid Door(s)



### STANDARD PRODUCT FEATURES

- High Performance, Energy Efficient Refrigeration System
- Reliable Microprocessor Control With LED Temperature Display
- Evaporator Coil Outside Food Zone Provides More Usable Space
- Load-Sure Guard Prevents Problems From Improper Loading
- Durable All Metal Construction
- Stainless Steel Front & Doors, Anodized Aluminum Sides & Interior
- Full or Half Height Door Models with a Variety of Hinging Configurations
- Long Life EZ-Clean Door Gaskets
- Three (3) Epoxy Coated Shelves Per Section (factory installed)
- Easy to Maintain Front Facing Condenser Coil
- 6" High Locking Casters
- Guaranteed for Life Door Handles & Hinges
- 3-Year Parts & Labor Warranty
- 2-Years Additional Compressor Parts Warranty



This unit is listed to the applicable UL, CSA and NSF Standards by an approved NRTL. Consult the factory or unit's data plate for approval information.

### ACCESSORIES & OPTIONS (\*field installed)

- ▣ Tray Slides for 18" x 26" Sheet Pans\*
- ▣ Tray Slides for 12" x 20" Food Pans\*
- ▣ Tray Slides for 14" x 18" Sheet Pans\*
- ▣ Tray Slides for 18" x 26, 12" x 20" & 14" x 18" Pans\*
- ▣ Additional Shelves\*
- ▣ 6" High Legs\*
- ▣ Lower Height Casters\*

\*Please refer to form number TR35872 for precise kit details. See back page for tray slide versatility chart.

### AVAILABLE CONFIGURATIONS

Half-Height	Control Side	Non Control Side
<b>Door Models</b>	<b>Hinging</b>	<b>Hinging</b>
G10002P	Right	Right
G10003P	Right	Left
G10004P	Left	Left
G10005P	Left	Right

Full-Height	Control Side	Non Control Side
<b>Door Models</b>	<b>Hinging</b>	<b>Hinging</b>
G10012P	Right	Right
G10013P	Right	Left
G10014P	Left	Left
G10015P	Left	Right

Approved by \_\_\_\_\_ Date \_\_\_\_\_ Approved by \_\_\_\_\_ Date \_\_\_\_\_



CLICK  
**TRANSFER**   
 For KCL CADalog Website

**MODELS**

Half Height Door Models: G10002P, G10003P, G10004P, G10005P

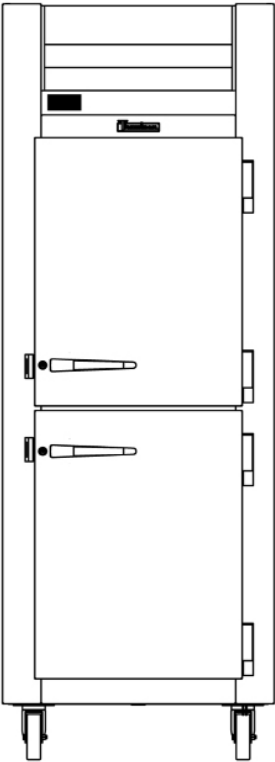

**G10002P Control Side**  
 Hinged Right Shown  
 (other hinging available)

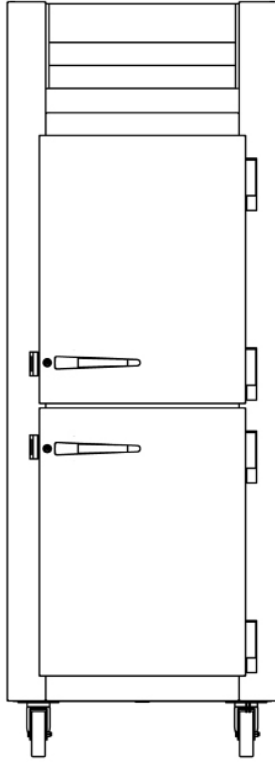

**G10002P Non Control Side**  
 Hinged Right Shown  
 (other hinging available)

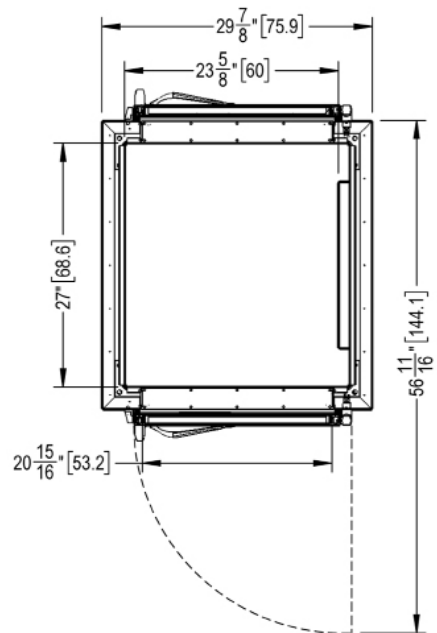
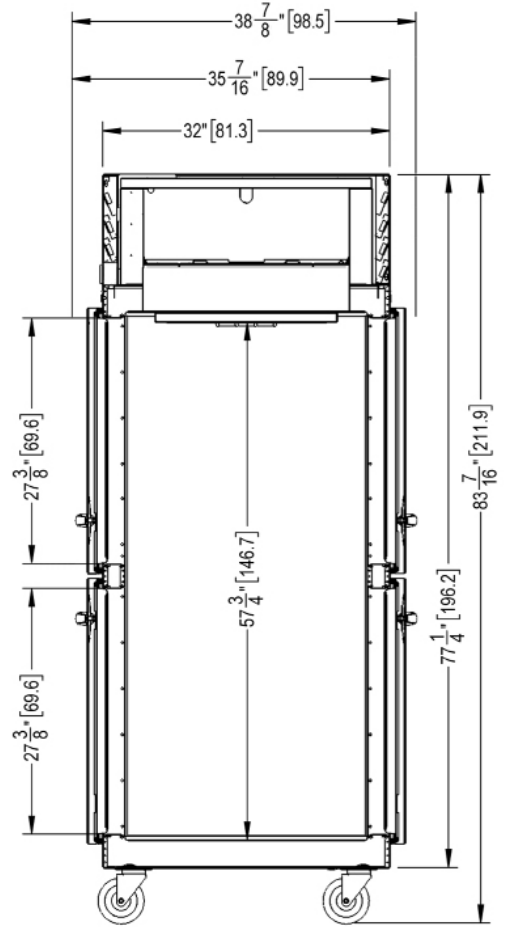

# G-SERIES

## 1-Section Refrigerator Pass-Thru Self-Contained Solid Door(s)

### MODELS

Full Height Door Models: G10012P, G10013P, G10014P, G10015P

CLICK  
**TRANSFER**  
For KCL CADalog Website

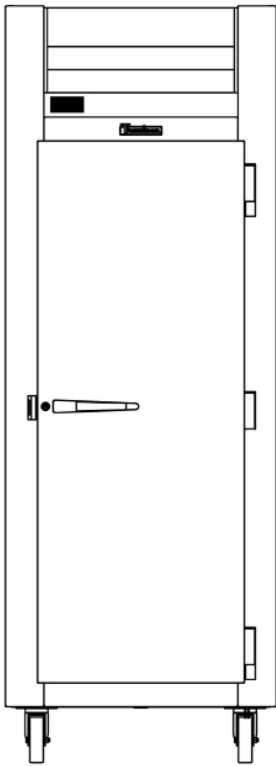

**G10012P Control Side**  
Hinged Right Shown  
(other hinging available)

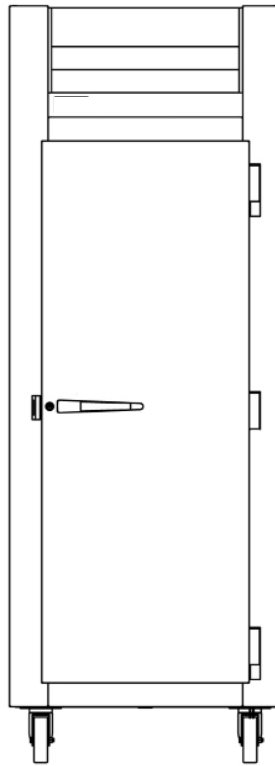

**G10012P Non Control Side**  
Hinged Right Shown  
(other hinging available)

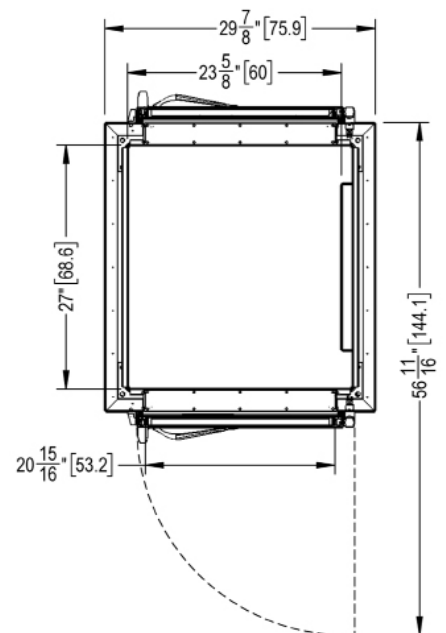
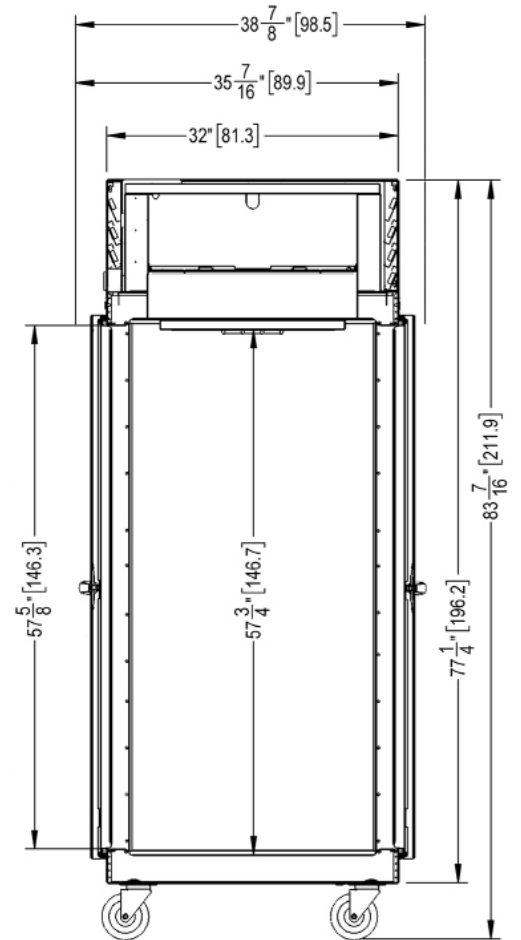



# G-SERIES

## 1-Section Refrigerator Pass-Thru Self-Contained Solid Door(s)

### MODELS

Half Height Door Models: G10002P, G10003P, G10004P, G10005P

Full Height Door Models: G10012P, G10013P, G10014P, G10015P

MODELS	G100__P
<b>DIMENSIONAL DATA</b>	
Net Capacity cu. ft. <sup>1</sup>	24.72 (699.9 l)   24.85 (703.6 l)
L x D x H - Overall in. <sup>2</sup>	29 <sup>7</sup> / <sub>8</sub> (75.9 cm) x 37 <sup>15</sup> / <sub>16</sub> (96.4 cm) x 83 <sup>7</sup> / <sub>16</sub> (211.9 cm)
Depth - over body in.	32 (81.3 cm)
Depth - door open 90° in.	57 <sup>7</sup> / <sub>8</sub> (146.3 cm)
Clear half-door W x H in.	21 <sup>1</sup> / <sub>8</sub> (53.6 cm) x 27 <sup>1</sup> / <sub>2</sub> (69.9 cm)
Clear full-door W x H in.	21 <sup>1</sup> / <sub>8</sub> (53.6 cm) x 57 <sup>7</sup> / <sub>8</sub> (146.3 cm)
No. Standard Shelves	3
Shelf Area sq. ft. <sup>3</sup>	18.8 (1.75 sq m)
<b>ELECTRICAL DATA</b>	
Voltage   Plug	115/60/1   NEMA 5-15P (attached)
Feed wires with ground	3
Full Load Amperes   MDEC <sup>4</sup>	4.9   2.47 kWh/Day
<b>REFRIGERATION DATA</b>	
Refrigerant	R-450A
Refrigerant Charge Amount	16 oz (453.6 g)
BTU/HR   H.P. <sup>5</sup>	1650   1/5 HP
Required Clearance	12" Above
<b>SHIPPING DATA</b>	
L x D x H Crated in.	48 (122 cm) x 42 (107 cm) x 85 (216 cm)
Volume Crated cu. ft.	99 (2803 l)
Uncrated   Crated Weight lbs.	320 (145 kg)   365 (166 kg)

#### NOTES:

1. Net Capacity cu. ft. = Half Height Door | Full Height Door models.
2. Height shown when mounted on standard 6" high casters.
3. Figure shown reflects the area of standard shelf complement.
4. MDEC = Maximum Daily Energy Consumption
5. Based on a 90°F ambient and 20°F evaporator.

### EQUIPMENT SPECIFICATIONS

#### CONSTRUCTION, HARDWARE, INSULATION

Cabinet exterior front, louver assembly and doors are constructed of stainless steel. Cabinet sides (including returns), interior and door liners are constructed of anodized aluminum. The exterior cabinet top and bottom are constructed of heavy gauge galvanized steel. A set of four (4) 6" (15 cm) high casters are included.

Doors are equipped with removable plug cylinder locks and guaranteed for life cam-lift, gravity action, self-closing metal, glide hinges with stay open feature at 120 degrees. Hinges include a concealed switch to automatically activate the interior LED lighting.

Gasket profile and durable long life material simplify cleaning and increase overall gasket life. Anti-condensate heaters are located behind each door opening.

The cabinet is insulated with an average of 2" (5 cm) thick high density, non-CFC, foamed in place polyurethane.

#### SELF-CONTAINED REFRIGERATION SYSTEM

A top mounted, self-contained, refrigeration system using environmentally friendly, non-flammable R-450A refrigerant is conveniently located behind the one piece louver assembly. It features an easy to clean front facing condenser, thermostatic expansion valve, air-cooled hermetic compressor, large, high humidity evaporator coil located outside the food zone and a top mounted non-electric condensate evaporator. A 9' (2.7 m) NEMA cord and 15-5P plug is provided. Standard operating temperature is 34° to 38°F (1° to 3°C).

#### CONTROL

The easy to use water resistant microprocessor control system is supplied standard. It includes a 3-Digit LED Display with both a Fahrenheit or Celsius Temperature Scale Display Capability.

#### INTERIOR ARRANGEMENTS

Standard interior arrangements include three (3) epoxy coated wire shelves per section, mounted on shelf pins, installed at the factory. Shelves are full-width, and do not have any large gaps between them requiring the use of "bridge" or "junior shelves." Recommended load limit per shelf should not exceed 225 lbs. (102kg).

#### DOMESTIC WARRANTY

Both a three year parts and labor warranty and a five year compressor warranty (self-contained models only) are provided standard.

### OPTIONAL ACCESSORY TRAY SLIDE VERSATILITY CHART

TRAY SLIDE DRAWINGS						
TRAY SLIDE OFFERING	#1 (1) 18" x26" or (2) 14"x18"	#4 (Rod Type) (1) 18" x26"	Universal (1) 18" x26" or (2) 14"x18" or (2) 12"x20"	#1 EZ-Change (1) 18" x26" or (2) 14"x18"	Universal EZ-Change (1) 18" x26" or (2) 14"x18" or (2) 12"x20"	HD Universal EZ-Change (1) 18" x26" or (2) 14"x18" or (2) 12"x20"
SPACING CAPACITY DOOR SIZE	2" 28 Pairs Full Door & 13 Half 3" 19 Pairs Full Door & 09 Half 4" 14 Pairs Full Door & 07 Half 5" 11 Pairs Full Door & 05 Half	1 1/2" 38 Pairs Full Door (2 Pair) 1 1/2" 18 Pairs Half Door (1 Pair)	4" 14 Pairs Full Door & 06 Half <sup>1</sup> 4" 14 Pairs Full Door & 07 Half <sup>2</sup> 5" 11 Pairs Full Door & 05 Half 6" 09 Pairs Full Door & 04 Half	2" 26 Pairs Full Door & 12 Half 4" 13 Pairs Full Door & 06 Half	2 1/4" 22 Pairs Full Door & 11 Half 4 1/2" 11 Pairs Full Door & 05 Half	4 1/2" 11 Pairs Full Door & 05 Half 9" 05 Pairs Full Door & 02 Half

- Upper Half Height Door<sup>1</sup>
- Lower Half Height Door<sup>2</sup>

CONTINUED PRODUCT DEVELOPMENT MAY NECESSITATE SPECIFICATION CHANGES WITHOUT NOTICE.