

DISPLAY REFRIGERATOR

Model: 2RESNSGD

Natural Refrigerant R-290 Model

2-Section Extra-Wide Display Reach-In Refrigerator with Sliding Glass Doors - Shallow Depth

2RESNSGD - Stainless steel front, aluminum end panels and interior

2RESNSASGD - Stainless steel exterior, aluminum interior

2RESNSSGD - Stainless steel exterior and interior

Designed to maintain NSF-7 temperatures in 100°F ambient.



Options and Accessories

(upcharge and lead times may apply)

Stainless steel case back	Wine rack
Additional epoxy coated steel shelves	Adjustable legs
Chrome or stainless steel shelves	Expansion valve
Heavy duty pilaster strips	Special electrical requirements (consult factory)

Consult factory for other model configurations, options and accessories.

Continental
Refrigerator



Project Name:

Model Specified:

Location:

Item No:

Quantity:

AIA #:

SIS #:

Standard Model Features

REFRIGERATION SYSTEM

Self contained, performance rated refrigeration system

Natural, environmentally safe, high efficiency R-290 refrigerant¹

Automatic, electric condensate evaporator

CABINET ARCHITECTURE

3" non-CFC polyurethane foam insulation

Double-pane, tempered sliding glass doors

Snap in door wiper

Self-closing doors

Heavy duty, epoxy coated steel shelves

5" casters

MODEL FEATURES

LED interior lighting

Electronic control, off cycle defrost

¹ R-290 refrigerant meets all federal and state regulatory requirements.

APPROVAL:

Model Specifications

DIMENSIONAL DATA

Net Capacity (cubic feet)	40 (1016 l)
Width, Overall (inches)	57 (1448 mm)
Depth, Overall (inches) (including grill)	27 ⁷ / ₈ (708 mm)
Depth (inches) (less grill)	25 ⁷ / ₈ (657 mm)
Clear Door Width (inches)	21 ⁷ / ₈ (556 mm)
Clear Door Height (inches)	54 ³ / ₄ (1391 mm)
Height, Overall (inches) (including 5" casters)	82 ¹ / ₄ (2089 mm)
Number of Doors	2
Number of Shelves	8
Shelf Area (square feet)	44.5 (4.1 sq m)

REFRIGERANT DATA

Condensing Unit Size (H.P.)	1/3
R-290 Refrigerant Charge (oz)	4.6
Capacity (BTU per hour)*	2540

ELECTRICAL DATA

Voltage (International)	115/60/1 (220/50/1)
Feed Wires (including ground)	3
Total Amps (International)	6.0 (3.0)
10 ft. Cord/Plug [attached] (International)	Yes (No)

SHIPPING DATA

Height - Crated (inches)	85 ¹ / ₂ (2172 mm)
Width - Crated (inches)	64 (1626 mm)
Depth - Crated (inches)	42 (1067 mm)
Volume - Crated (cubic feet)	133 (3766 cu l)
Weight Std - Crated (pounds)	460 (210 kg)
Weight SS - Crated (pounds)	555 (252 kg)

* Rating @ +25°F evaporator, 90°F ambient
Figures in parentheses reflect metric equivalents rounded to the nearest whole unit.



Equipped with one NEMA-5-15P Plug
(varies by country)

Continental
Refrigerator

Toll-Free: 800-523-7138
Phone: 215-244-1400
Fax: 215-244-9579

539 Dunksferry Road
Bensalem, PA 19020
www.continentalrefrigerator.com

Due to our continued efforts in developing innovative products, specifications subject to change without notice.



PROUDLY
DESIGNED & ASSEMBLED
IN THE U.S.A.

© Copyright 2021. Continental Refrigerator.
A Division of National Refrigeration & Air Conditioning Products, Inc.

Model Plan Views

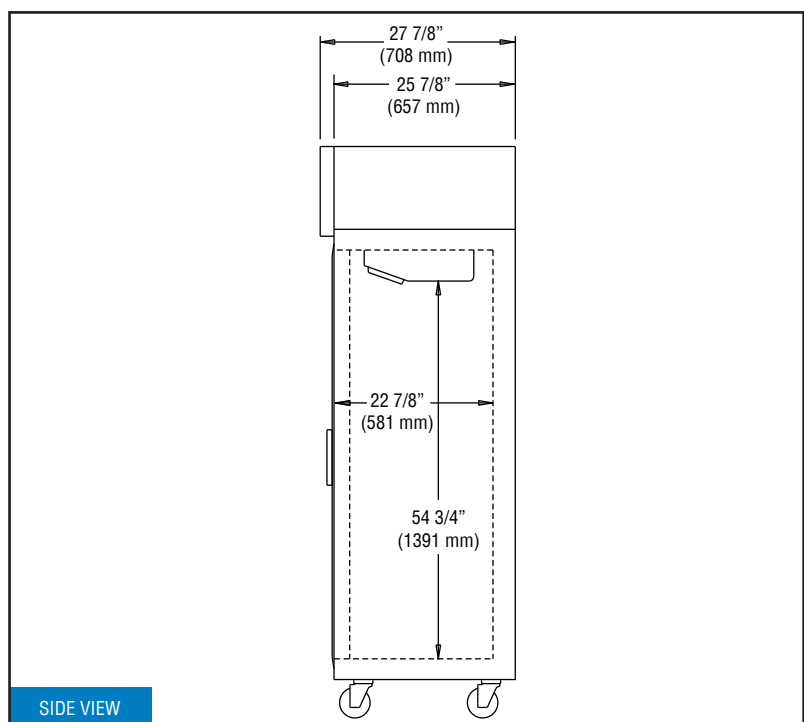
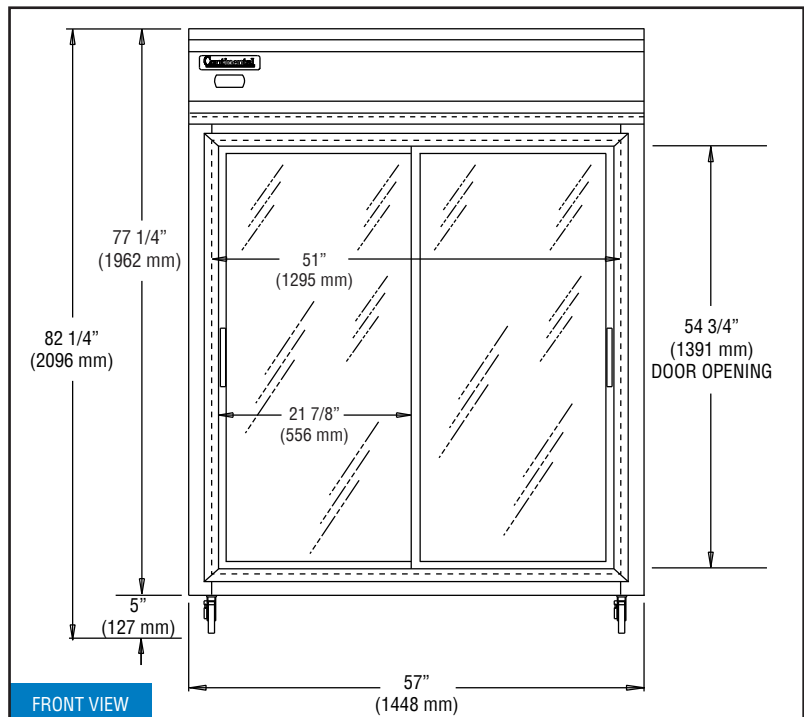

IMPORTANT NOTE: If the cabinet is located directly against a wall and/or under a low ceiling, a minimum clearance of 12" is required on top and 3" on sides and rear.

REVISED: 12/24/25