

Instinct Induction Countertop Wok

Project _____
 Item _____
 Quantity _____
 CSI Section 11400
 Approved _____
 Date _____

Models

- GIIC-SW3.5
- GIIC-SW5.0

powered by
INDUCS



GIIC-SW3.5

Standard Features

- Realtime Temperature Control System (RTCSmp)
- 12 power levels
- Easy to clean, high-temperature Ø 300 mm Ceran™ wok glass
- Timer function
- Superior energy-efficiency
- Convenient and reliable
- Short heat-up times
- Overheat protection
- LED Display
- Includes plug and cord (1.8 m - 6 ft.)
- Simple and intuitive "Tap and Turn" knob

Advanced Features

- RTCSmp control/monitoring
- Height-adjustable, locking feet
- Washable air filter
- Incoming voltage detection
- Easy power reduction
- Quiet ventilation for less noise

Specifications

Continuous temperature measurement at the bottom of the pan with Realtime Temperature Control System multi-point technology (RTCSmp).

The reliable overheating protection prolongs the service life of both the induction appliance and the cookware.

Consistent power transfer over the entire cooking time for optimal cooking results.

Convenient cooking without heating up the cooking environment thanks to direct heat transfer from the hob to the pan by means of induction.

Easy to clean thanks to a removable, washable and reusable air filter.

Cool to touch cooking surface, means no "burn on" of food debris on the cooking surface.

Exceptionally robust and developed for continuous operation in the restaurant industry.

Reduction of the maximum power from 100% to 25%.

Mains voltage detection and automatic loading of the optimal parameters. Single-phase version (up to 3.5 kW) at 208V - 240V: identical worldwide.

Automatic shut-off feature prohibits overheating.

The unit fits the power that the operator has available.

Warranty: 2 years on parts & labor (US and Canada only).

NOTE: Induction cooking requires use of induction-compatible cookware.





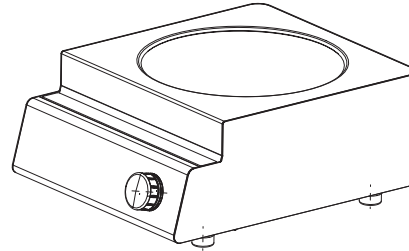
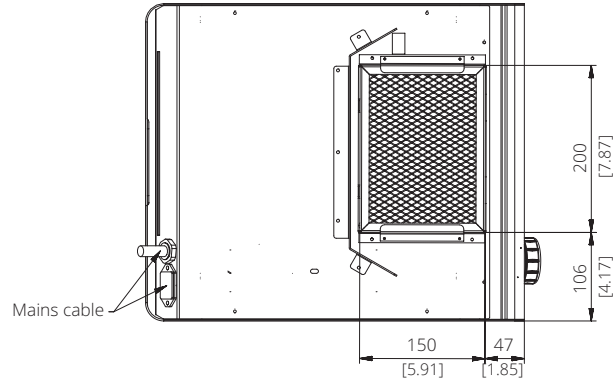
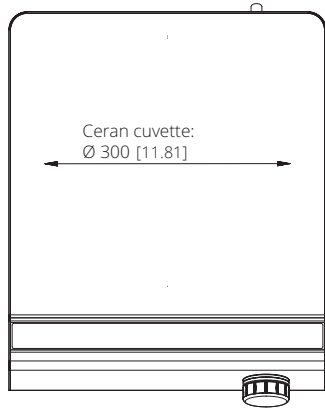
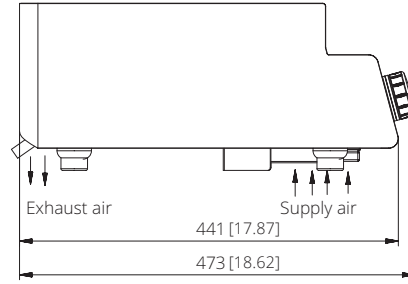
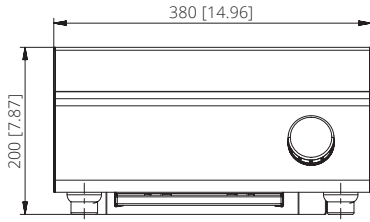

Instinct Induction Countertop Wok

Dimensions are specified in mm [inches]



Number of heating zones: 1
 Ceran™ glass surface: ø 300 mm [11.8 inches] wok Ceran™ bowl
 Inductor diameter: ø inductor coil 270 mm [10.63 inches]
 Power levels: 12
 Housing: stainless steel

Model	GIIC-SW3.5		GIIC-SW5.0	
Part Number	99570019		99570014	99570015
Dimension W x D x H	380 x 473 x 200 mm [14.96 x 18.62 x 7.87 inches]		380 x 473 x 200 mm [14.96 x 18.62 x 7.87 inches]	
Weight	14 kg [31 lbs]		16 kg [36 lbs]	
Electrical Specifications (EU/US)	Single Phase		3 Phases	
Power, Watts	3500W		5000W	
Electrical supply V/Hz	208-240 V/50-60 Hz/1 17A		208-240 V/50-60 Hz/3 14A	380-440 V/50-60 Hz/3 8A
Plug	 EU1-16P	 NEMA 6-20P	 NEMA L15-20P	 EU 5-Pole
Shipping Information				
Dimensions W x D x H	670 x 470 x 290 mm [26.38 x 18.51 x 11.42 inches]		670 x 470 x 290 mm [26.38 x 18.51 x 11.42 inches]	
Weight	18 kg [40 lbs]		19 kg [42 lbs]	

Note:
 Garland products are not approved or authorized for home or residential use, but are intended for commercial applications only.
 Garland will not provide service, warranty, maintenance or support of any kind other than in commercial applications.

Garland reserves the right to make changes to the design or specifications without prior notice.