



TRUE MANUFACTURING CO., INC.
U.S.A. FOODSERVICE DIVISION

2001 East Terra Lane • O'Fallon, Missouri 63366-4434 • (636)240-2400
Fax (636)272-2408 • Toll Free (800)325-6152 • Intl Fax# (001)636-272-7546
Parts Dept. (800)424-TRUE • Parts Dept. Fax# (636)272-9471 • www.truemfg.com

Project Name: _____

Location: _____

Item #: _____ Qty: _____

Model #: _____

A/A #

S/S #

Model:

TUC-48D-4-HC~SPEC3

Undercounter:

Drawered Refrigerator with Hydrocarbon Refrigerant~Spec Package 3



TUC-48D-4-HC~SPEC3

- ▶ True's undercounter units are designed with enduring quality that protects your long term investment.
- ▶ Designed using the highest quality materials and components to provide the user with colder product temperatures, lower utility costs, exceptional food safety and the best value in today's food service marketplace.
- ▶ Factory engineered, self-contained, capillary tube system using environmentally friendly R290 hydro carbon refrigerant that has zero (0) ozone depletion potential (ODP), & 0.02 global warming potential (GWP).
- ▶ Stainless steel front, countertop, sides, and back.
- ▶ Interior - Stainless steel liner. Stainless steel floor with coved corners.
- ▶ Heavy duty 20 gauge drawers.
- ▶ Heavy duty all metal working spec door handle.
- ▶ Counter-Top front is flush with front of drawers.
- ▶ Electronic temperature control with digital display.
- ▶ Each drawer accommodates one (1) full size 12"L x 18"W x 6"D (305 mm x 458 mm x 153 mm) food storage box (sold separately).
- ▶ Foamed-in-place using a high density, polyurethane insulation that has zero ozone depletion potential (ODP) and zero global warming potential (GWP).
- ▶ Spec Series® logo.

ROUGH-IN DATA

Chart dimensions rounded up to the nearest 1/8" (millimeters rounded up to next whole number).

Specifications subject to change without notice.

Model	Drawers	Cabinet Dimensions (inches) (mm)			HP	Voltage	Amps	NEMA Config.	Cord Length (total ft.) (total m)	Crated Weight (lbs.) (kg)
		W	D†	H*						
TUC-48D-4-HC~SPEC3	4	48 3/8	29 1/8	29 3/4	1/5	115/60/1	2.0	5-15P	10	330
		1229	740	756	1/5	220-240/50-60/1	1.0	▲	3.05	150

† Depth does not include 1 1/2" (39 mm) for drawer handles. † Depth does not include 1" (26 mm) for rear bumpers.

* Height does not include 6 1/4" (159 mm) for castors or 6" (153 mm) for optional legs.

▲ Plug type varies by country.



APPROVALS:

AVAILABLE AT:

Model:
TUC-48D-4-HC~SPEC3

Undercounter:
Drawered Refrigerator with Hydrocarbon
Refrigerant~Spec Package 3



STANDARD FEATURES

DESIGN

- True's commitment to using the highest quality materials and oversized refrigeration systems provides the user with colder product temperatures, lower utility costs, exceptional food safety and the best value in today's food service marketplace.

REFRIGERATION SYSTEM

- Factory engineered, self-contained, capillary tube system using environmentally friendly R290 hydro carbon refrigerant that has zero (0) ozone depletion potential (ODP), & 0.02 global warming potential (GWP).
- Oversized, factory balanced refrigeration system with guided airflow to provide uniform product temperatures.
- High capacity, factory balanced refrigeration system that maintains cabinet temperatures of 33°F to 38°F (.5°C to 3.3°C) for the best in food preservation.
- State of the art, electronically commutated evaporator and condenser fan motors. ECM motors operate at higher peak efficiencies and move a more consistent volume of air which produces less heat, reduces energy consumption and provides greater motor reliability.
- Condensing unit access in back of cabinet, slides out for easy maintenance.

CABINET CONSTRUCTION

- Exterior - stainless steel front, top, sides, and back.
- Interior - Stainless steel liner. Stainless steel floor with coved corners.

- Insulation - entire cabinet structure and drawer facings are foamed-in-place using a high density, polyurethane insulation that has zero ozone depletion potential (ODP) and zero global warming potential (GWP).
- 5" (127 mm) diameter stem castors - locks provided on front set. 36" (915 mm) work surface height.

DRAWERS

- Stainless steel exterior drawer facings and liners. Stainless steel drawer frames.
- Heavy duty 20 guage drawers.
- Drawer locks standard.
- Each drawer fitted with heavy duty all metal working spec handle.
- Heavy-duty stainless steel drawer slides and rollers. Removable without tools for easy cleaning.
- Magnetic drawer gaskets of one piece construction, removable without tools for ease of cleaning.
- Drawers will support a wide variety of incremental pan size configurations; divider bars available.
- Each drawer accommodates one (1) full size 12"L x 18"W x 6"D (305 mm x 458 mm x 153 mm) food storage box or one 1/2 size and one 1/2 size pan (sold separately).

MODEL FEATURES

- Evaporator is epoxy coated to eliminate the potential of corrosion.
- Counter-Top front is flush with front of drawers.
- Electronic temperature control with digital display.
- Spec Series® logo.
- NSF/ANSI Standard 7 compliant for open food product.

ELECTRICAL

- Unit completely pre-wired at factory and ready for final connection to a 115/60/1 phase, 15 amp dedicated outlet. Cord and plug set included.



OPTIONAL FEATURES/ACCESSORIES

- Upcharge and lead times may apply.
- 230-240V / 5-600 Hz.
 - 6" (153 mm) standard legs.
 - 6" (153 mm) seismic/flanged legs.
 - 2 1/2" (64 mm) diameter castors.
 - Single overshelf.
 - Double overshelf.
 - TUC-27 Stacking collar.
 - Cutting boards provided by others. Requires "L" brackets. Field installed brackets provided by True (contact factory).
 - ADA compliant models with 34" (864 mm) work surface height.
 - Low profile models with 31 7/8" (810 mm) work surface height.
 - Heavy duty 16 gauge top.

PLAN VIEW

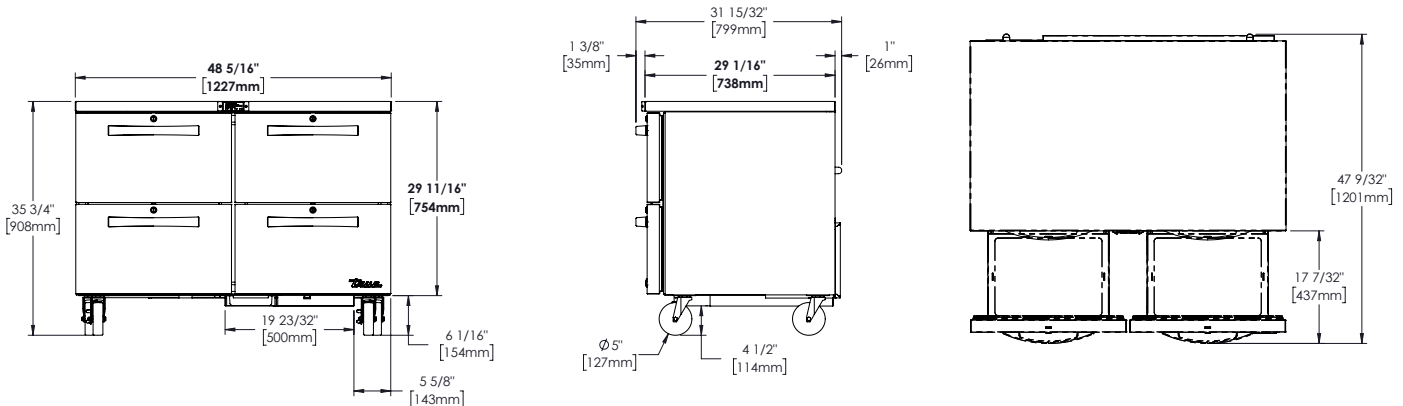

METRIC DIMENSIONS ROUNDED UP TO THE NEAREST WHOLE MILLIMETER
 SPECIFICATIONS SUBJECT TO CHANGE WITHOUT NOTICE



Model	Elevation	Right	Plan	3D	Back
TUC-48D-4-HC~SPEC3					

TRUE MANUFACTURING CO., INC.