

ITEM #



MS Series

Wood-Fired Oven, Metal Exterior, Square
MS83-31W

Experience a level of quality that is Italian-inspired, but manufactured for the needs of North American restaurants. Marra Forni brick ovens combine traditional artisanal workmanship, such as a full refractory brick enclosure for outstanding performance, with modern manufacturing technology and design innovation. Each oven is hand-made, brick-by-brick, using the same time-proven techniques that masons have used for generations.

Each model features our unique Marra Stone® stone-hearth cooking surface as its heart. This proprietary refractory brick surface includes volcanic material, for outstanding cooking results as well as constant temperatures for consistency. Insulated construction allows heat to be absorbed and retained in the oven cavity for improved efficiency.

Marra Forni MS Series “metal square” ovens combine a flush, square metal exterior with our standard traditional brick oven interior. This provides a unique oven solution, offering all of the performance advantages of our traditional Neapolitan brick oven solutions while also providing an easy-to-clean exterior that permits installation in more restricted areas. Classic wood-fired heating imparts traditional flavor profiles and enhances cooking adjustability. While known best for cooking pizza, these ovens are designed to support a variety of cuisines and cooking applications.



Standard Features

- MarraStone® stone hearth deck is of a refractory brick that includes volcanic material. This deck is both durable and highly porous, and is capable of maintaining cooking temperatures from 200-950°F (93-510°C) for consistent high-volume production
- Superior cooking performance and recovery based upon natural convective airflow within the oven chamber, and the heat retention of custom formulated refractory bricks
- Wood-burning heating provides traditional cooking flavors
- Flush metal exterior front and side panels
- Integrated “eyebrow” exhaust duct at the loading/unloading entrance is integrated into the structure of the oven, greatly reducing emissions into the room while enhancing staff visibility of oven interior
- Suitable for either direct venting or installation under a Type 1 ventilation hood (subject to local and national code requirements)
- 1-1/4” (32mm)-thick black granite ledge
- Painted matte black steel front facade and side panels
- Heavy duty black powder-coated steel stand
- Manufactured in the U.S.A.

Cooking Capacity (typical)

- 8” (200mm) pizzas: 19
- 10” (250mm) pizzas: 16
- 12” (300mm) pizzas: 12
- 16” (400mm) pizzas: 4

Production capacity varies depending upon type of food product being cooked, food preparation and set temperature.

Total Cooking Surface 17.87 sq. ft. (1.66 sq. m)

Cooking Deck Dimensions 82-3/4 x 31-3/8” (2102 x 797mm)

Configuration Options (Check all that apply)

Fuel Type

- Wood-Fired

Options

- Direct Ventilation (quoted separately)
- Exhaust Fan with Variable Speed Fan Control
- Integrated Fan Interlock
- Stainless Steel Facade
- Stainless Steel Stand
- Stainless Steel Front and Side Panels
- Interior Light Box
- Customized Tile Upgrade (front and side panels)
- Base Enclosure (Side Panels)
- Base Enclosure (Full Skirt Enclosure)

Accessories

- Dough Tray
- Dough Tray Lid(s)
- Dough Tray Dolly
- Standard Peel Tool Kit
- Deluxe Peel Tool Kit
- Wall Mounted Tool Rack



CSA 1.8 | UL 2162 | ULC/ORD C2162 | NSF/ANSI 4

MS Series
MS83-31W

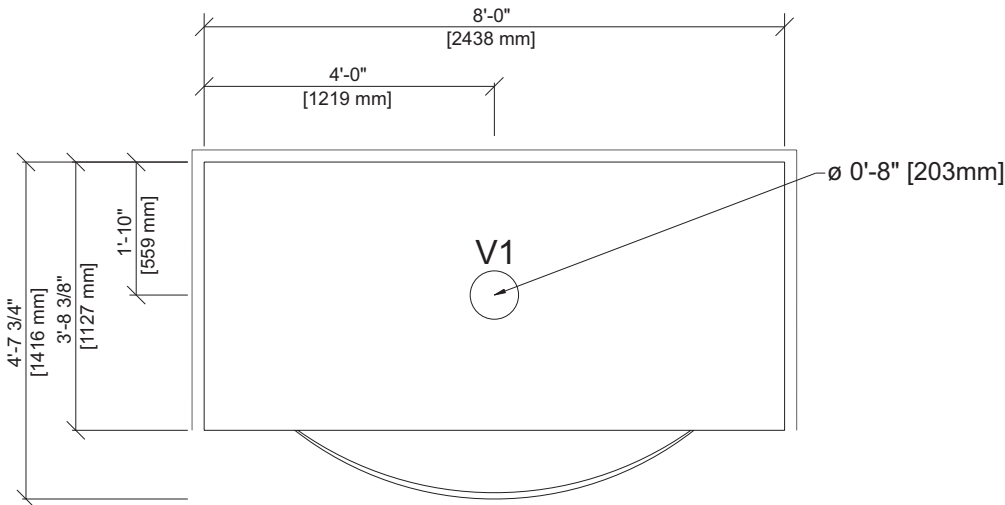
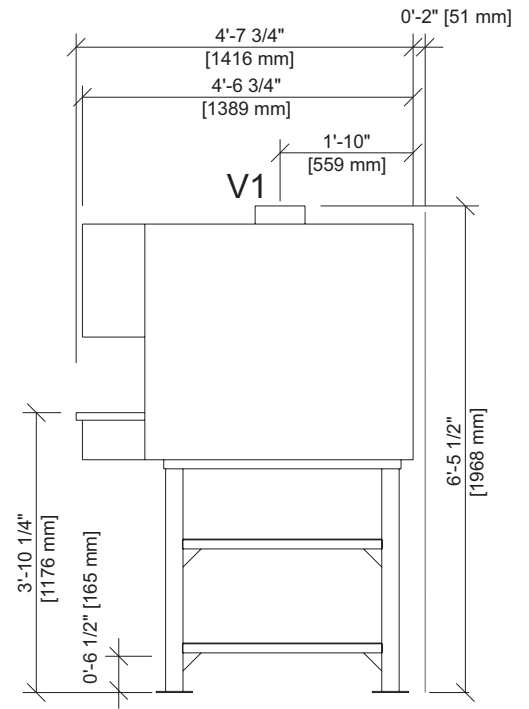
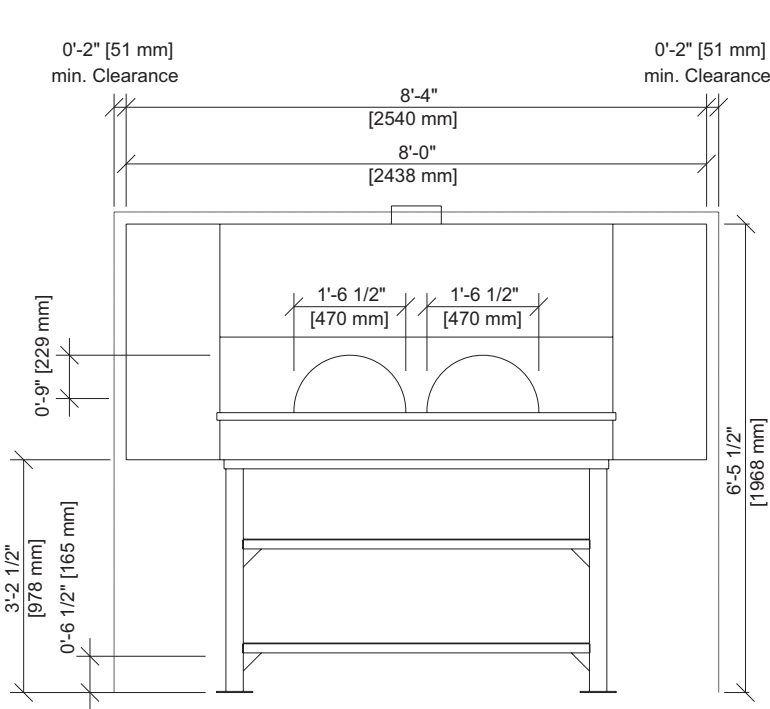

Solid fuel loading (through front door)

Wood
Volume and wood type is dependent on desired flavor profile and baking temperature



Ventilation connection
8" (203mm) dia.

For utility loads and connection details, refer to Page 3 of this spec sheet.

All specifications are subject to change without notice, based on Marra Forni's commitment to ongoing product development and improvement measures. Ovens are designed only for the cooking of manufacturer-approved food products in commercial and institutional settings, and should not be used for any other purpose.

Dimensional Information

- Minimum clearance: 2" (51mm) on all sides and rear from combustible surfaces, 0" (0mm) from non-combustible surfaces, 18" (450mm) side clearance recommended for service access
- Exterior: (H x W x D): 77-1/2" x 96" x 55-3/4" (1968 x 2438 x 1416mm)
- Shipping: (H x W x D): 86-1/2" x 78" x 102" (2197 x 1981 x 2591mm)
- Weight: 2,911 lbs. (1320 kg)
- Crated Weight: 3,311 lbs. (1502 kg)
- Freight Class: 77.5, shipped LTL

Ventilation Connection Requirements

Connection	Volume	Static Pressure
8" (203mm)	150 CFM	0.01" W.C.
round collar	255 m ³ h	2.5 Pa

Oven may be installed with an approved direct vent system, or an approved Type 1 exhaust hood system. Ventilation system must comply with all applicable local and national codes.

If direct ventilation is desired, a Marra Forni-designed optional vent system is available as an option and is strongly recommended. This option also requires the exhaust fan (with variable speed fan control) option.

If not using a Marra Forni-supplied direct ventilation connection, determining correct ventilation and code compliance is the responsibility of others.

Specification

MS83-31W Item # _____

Unit will be an ETL-listed Marra Forni MS83-31W freestanding, wood heated brick oven, intended for cooking and baking pizza and other approved food products.

Unit heating will be provided by wood burning.

Unit will feature a stone hearth cooking deck composed of a refractory brick composition, including volcanic material, to provide and maintain cooking temperatures up to 950°F (510°C).

Unit cooking area will measure 82-3/4" W x 31-3/8" D (2102 x 797mm).

Unit will feature two individual door openings. Each door opening will measure 18-1/2" (470mm) in width and 9" (229mm) in height.

Unit will feature a brick interior for superior heat retention and distribution within the cooking chamber.

Unit will feature a flush metal exterior.

Unit will include an oven mantle featuring a 1-1/4" (32mm)-thick black granite ledge.

Unit will include a black powder-coated steel stand and painted matte black steel facade, front and side panels.

Unit will be manufactured in the U.S.A. and comply with all applicable FTC requirements for this status.