

# eurodib

## M20B



The M20B planetary mixer will help you with your culinary creations. It's robust construction and powerful motor will effortlessly mix, knead and emulsify the ingredients guaranteeing consistent results every time.

### FEATURES

- Compact design ideal for medium-sized kitchens.
- Durable stainless steel construction guaranteeing long-term reliability and consistent performance.
- Intuitive controls for simple user-friendly operation.
- Exceptional value with quality assurance for professional results.
- This mixer is **NOT** suited for mixing bread or pizza dough.



PARTS AND  
LABOR

### CAPACITY CHART

Bowl size:	21 qt. (20 L)
Egg whites:	1.1 qt. (1 L)
Marshmallow:	2.2 lb (1 kg)
Cake batter:	15.5 lb (7 kg)
Cookie dough:	12 lb (5.5 kg)
Bread dough:	<b>NOT SUITABLE</b>
Pizza dough:	<b>NOT SUITABLE</b>

### SPECIFICATIONS

Power:	110 V, 1100 W, 9 A, 5-15P
Capacity:	20 qt. (18 L)
Bowl depth:	12" (30 cm)
Bowl diameter:	14" (35 cm)
Mixing speed:	113/168/386 rpm
Max. kneading cap.:	13 lb/h (6 kg/h)
Dimensions:	
Length:	21.5" (54 cm)
Width:	17.5" (44 cm)
Height:	30.6" (77 cm)

Connection:  (110 V)

Net weight:	216 lb (98 kg)
Shipping dimensions:	
Length:	42" (106 cm)
Width:	32" (81 cm)
Height:	31" (78 cm)
Shipping weight:	295 lb (133 kg)

### Included accessories

- Bowl
- Spiral hook
- Whip
- Beater
- Meat grinder attachment



**FRONTAL VIEW**

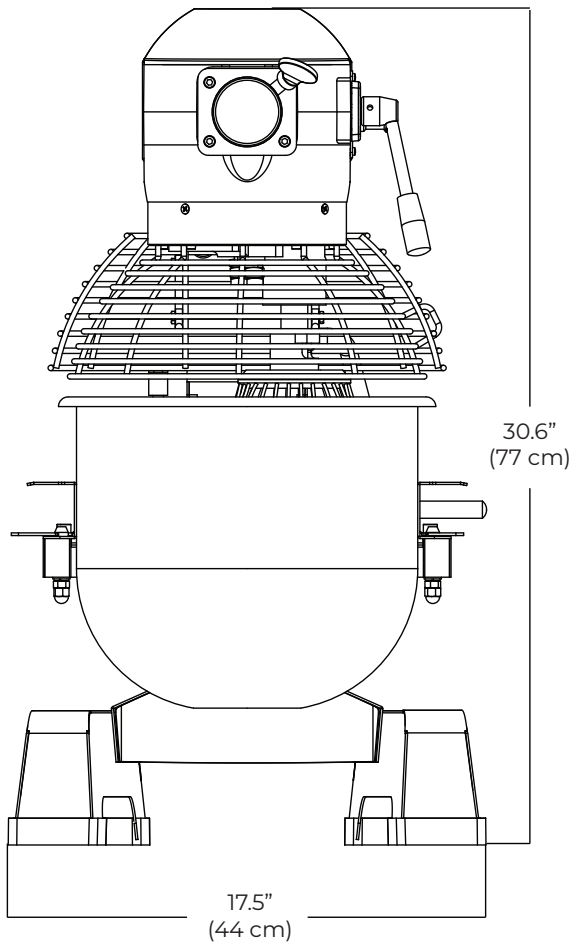

**TOP VIEW**

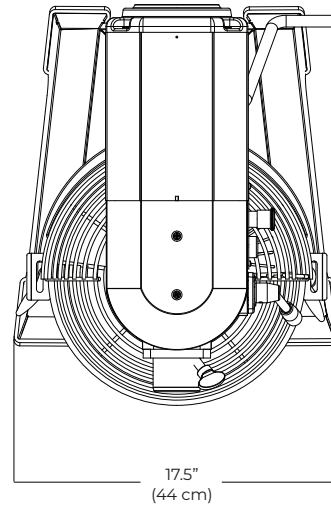

**LEFT VIEW**

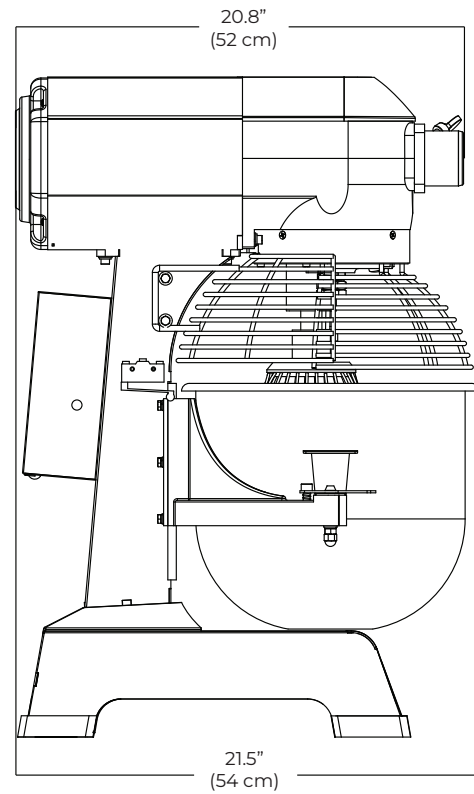

# eurodib

## M20B



Le mélangeur planétaire M20B vous aidera dans vos créations culinaires. Sa construction robuste et son moteur puissant mélangeront, pétriront et émulsionneront les ingrédients sans effort, garantissant ainsi des résultats constants à chaque fois.

### CARACTÉRISTIQUES

- Conception compacte idéale pour les cuisines de taille moyenne
- Construction durable en acier inoxydable garantissant une fiabilité à long terme et des performances constantes.
- Commandes intuitives pour une utilisation simple.
- Valeur exceptionnelle doublée d'une assurance-qualité pour des résultats professionnels.
- Ce mélangeur ne convient **PAS** pour la préparation de pâte à pain ou à pizza.



PIÈCES ET  
MAIN-D'ŒUVRE

### TABLEAU DES CAPACITÉS

Format du bol : 21 pte (20 L)

Blancs d'œufs : 1,1 pte (1 L)

Guimauve : 2,2 lb (1 kg)

Pâte à gâteau : 15,5 lb (7 kg)

Pâte à biscuit : 12 lb (5,5 kg)

Pâte à pain : **NE CONVIENT PAS**

Pâte à pizza : **NE CONVIENT PAS**

### SPÉCIFICATIONS

Puissance : 110 V, 1100 W, 9 A, 5-15P

Capacité : 21 pte (20 L)

Profondeur du bol : 12 po (30 cm)

Diamètre du bol : 14 po (35 cm)

Vitesse : 113/168/386 rpm

Capacité maximale de pétrissage :  
13 lb/h (6 kg/h)

Dimensions :

Longueur : 21,5 po (54 cm)

Largueur : 17,5 po (44 cm)

Hauteur : 30,6 po (77 cm)

Connexion :



(110 V)

Poids net : 216 lb (98 kg)

Dimensions d'expédition :

Longueur : 42 po (106 cm)

Largueur : 32 po (81 cm)

Hauteur : 31 po (78 cm)

Poids d'expédition : 295 lb (133 kg)

### Accessoires inclus

- Crochet
- Fouet
- Batteur
- Hachoir à viande



### VUE AVANT

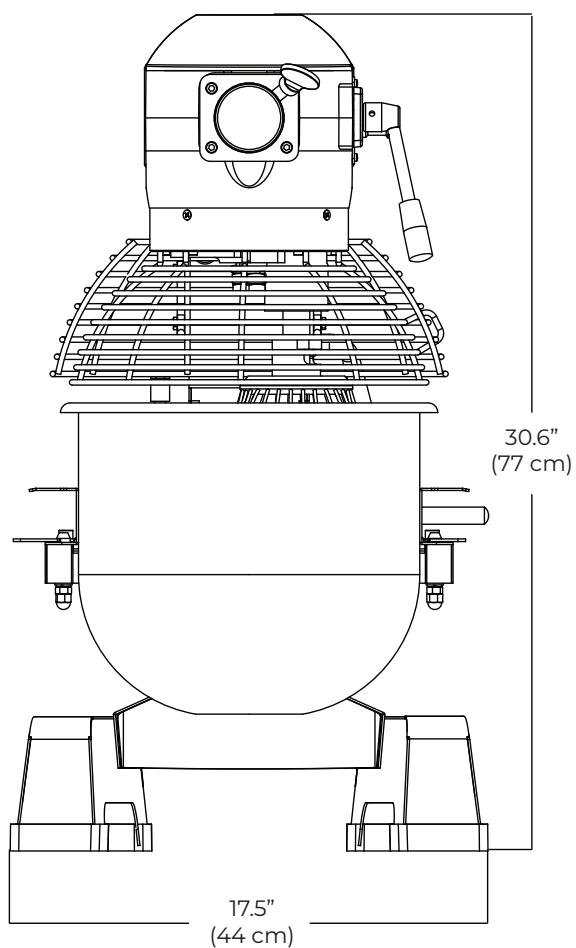

### VUE DE DESSUS

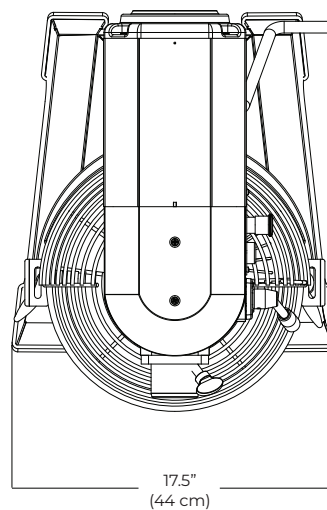

### VUE DE CÔTÉ GAUCHE

