



GAS

IMPERIAL

TUBE FIRED SIDE CAR FRYER FILTER SYSTEMS



IFSCB250

Filter System with Drain Station

MODEL NUMBERS

IFSCB150	IFSCB450
IFSCB175	IFSCB475
IFSCB250	IFSCB550
IFSCB275	IFSCB575
IFSCB350	IFSCB650
IFSCB375	IFSCB675

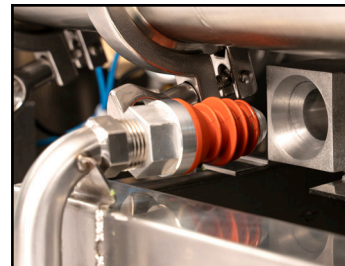

**With
Hands-free
Filter Connection System**

FILTER PACKAGE CHOICES

- Up to six fryers can be battered into one fryer / filter system.
- Available for 50 and 75 lb. (27 and 41 Liters) oil capacity fryers.
- Available in Snap Action Thermostats, Electronic Thermostats or Computer Controls.

LOCATED UNDER FRYERS

- Filter location under fryers saves valuable space.
- Internally plumbed oil drain and return line.

UNIQUE FILTER PAN DESIGN

- Filter pan is designed for maximum oil return.
- Stainless steel construction is easy to clean and has a professional look.
- Positive-latching filter paper holder holds paper in place for optimal filtration.
- Quick disconnect connection offers quick and safe connection of the filtered oil back into the frypots.
- All oil drain and return lines are internally plumbed for convenience and safety.

ROLLER-PUMP

- 5.5 GPM pump with a 1/3 HP motor speeds up filtering process
- Can pump oil into a disposal vat up to 20 feet away.
- Reclamation system

DRAIN STATION

- Includes a matching stainless steel cabinet with a food warmer and dump pan.
- Cabinet may be located anywhere within the fryer battery.
- Cabinet is a convenient storage area when located at the end of the battery.

EXTERIOR FEATURES

- Continuous cabinet provides a professional look.
- 5" (127 mm) deep continuous stainless steel front landing ledge.
- Stainless steel precision welded frypot.
- Includes casters, joiner strips and filter starter kit.
- Rear gas manifold with one point gas connection.
- Includes fryer tip brush.



**Touch Screen
Digital Controls
Now Available!**

IMPERIAL

1128 Sherborn Street | Corona, CA 92879 | 800.343.7790 | imperialrange.com | imperialsales@imperialrange.com

©2026 Imperial Commercial Cooking Equipment Imperial reserves the right to change specifications at any time without prior notice and without any obligation for past or future equipment purchases. Visit www.imperialrange.com for specification updates



GAS

TUBE FIRED SIDE CAR FRYER FILTER SYSTEMS

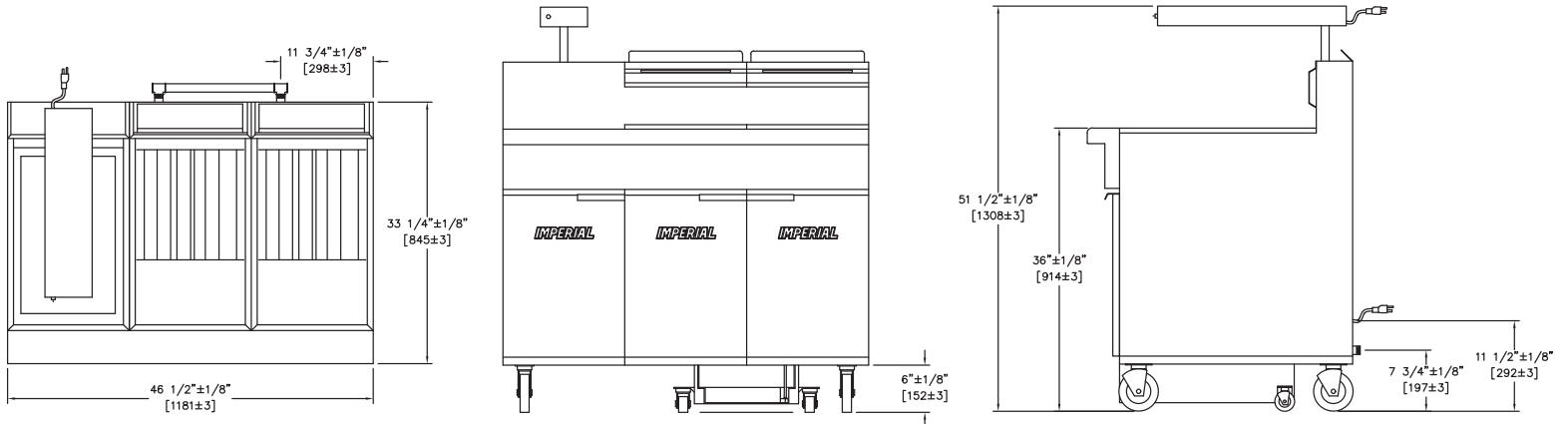

MODEL	OIL CAPACITY	WIDTH	FRYERS	SHIP WEIGHT KG	SHIP WEIGHT LBS
IFSCB150	50 LBS. (41 L)	31" (787 MM)	1	196	433
IFSCB250	50 LBS. (41 L)	46-1/2" (1181 MM)	2	311	686
IFSCB350	50 LBS. (41 L)	62" (1575 MM)	3	426	939
IFSCB450	50 LBS. (41 L)	77-1/2" (1969 MM)	4	541	1192
IFSCB550	50 LBS. (41 L)	93" (2362 MM)	5	655	1445
IFSCB650	50 LBS. (41 L)	108-1/2" (2756 MM)	6	770	1698
IFSCB175	75 LBS. (51 L)	39" (911 MM)	1	204	450
IFSCB275	75 LBS. (51 L)	58-1/2" (1486 MM)	2	327	720
IFSCB375	75 LBS. (51 L)	78" (1981 MM)	3	449	990
IFSCB475	75 LBS. (51 L)	97-1/2" (2477 MM)	4	572	1260
IFSCB575	75 LBS. (51 L)	117" (2972 MM)	5	694	1530
IFSCB675	75 LBS. (51 L)	136-1/2" (3467 MM)	6	816	1800

FILTER ELECTRICAL REQUIREMENT			
VOLTS	PHASE	HERTZ	AMPS
115 V	1	60	6.8 AMPS

6ft. (1829 mm) power cord with 3 prong plug provided

CLEARANCE

For use only on non-combustible floors with legs or casters. Provide 0" clearance from non-combustible surfaces and 6" (152 mm) from combustible surfaces.

OPTIONS AND ACCESSORIES

- Automatic basket lifts with computerized controls
- Manual controlled basket lifts
- Gas shut off valve, 3/4" N.P.T.
- Stainless steel tank cover
- Stainless steel side drain shelf
- Stainless steel side splash, 6"
- Goofer Declogger Rod
- Sediment Scooper
- Filter paper 40# thickness, 20 microns, 100 sheets per box



MODEL	DIMENSIONS	CRATED DIMENSIONS	MODEL	DIMENSIONS	CRATED DIMENSIONS
IFSCB150	31" W X 33-1/4" D X 51-1/2" H (787 X 845 X 1308 MM)	32-1/2" W X 38" D X 40" H (826 X 965 X 1016 MM)	IFSCB175	39" W X 40-1/2" D X 45-3/4" H (911 X 1029 X 1162 MM)	40-1/2" W X 43" D X 49-1/2" H (1029 X 1092 X 1257 MM)
IFSCB250	46-1/2" W X 33-1/4" D X 51-1/2" H (1181 X 845 X 1308 MM)	48" W X 38" D X 40" H (1219 X 965 X 1016 MM)	IFSCB275	58-1/2" W X 40-1/2" D X 45-3/4" H (1486 X 1029 X 1162 MM)	60" W X 43" D X 49-1/2" H (1524 X 1092 X 1257 MM)Z
IFSCB350	62" W X 33-1/4" D X 51-1/2" H (1575 X 845 X 1308 MM)	63-1/2" W X 38" D X 40" H (1613 X 965 X 1016 MM)	IFSCB375	78" W X 40-1/2" D X 45-3/4" H (1981 X 1029 X 1162 MM)	79-1/2" W X 43" D X 49-1/2" H (2019 X 1092 X 1257 MM)
IFSCB450	77-1/2" W X 33-1/4" D X 51-1/2" H (1969 X 845 X 1308 MM)	79" W X 38" D X 40" H (2007 X 965 X 1016 MM)	IFSCB475	97-1/2" W X 40-1/2" D X 45-3/4" H (2477 X 1029 X 1162 MM)	99" W X 43" D X 49-1/2" H (2515 X 1092 X 1257 MM)
IFSCB550	93" W X 33-1/4" D X 51-1/2" H (2362 X 845 X 1308 MM)	94-1/2" W X 38" D X 40" H (2400 X 965 X 1016 MM)	IFSCB575	117" W X 40-1/2" D X 45-3/4" H (2972 X 1029 X 1162 MM)	118-1/2" W X 43" D X 49-1/2" H (3010 X 1092 X 1257 MM)
IFSCB650	108-1/2" W X 33-1/4" D X 51-1/2" H (2756 X 845 X 1308 MM)	110" W X 38" D X 40" H (2794 X 965 X 1016 MM)	IFSCB675	136-1/2" W X 40-1/2" D X 45-3/4" H (3467 X 1029 X 1162 MM)	138" W X 43" D X 49-1/2" H (3505 X 1092 X 1257 MM)



1128 Sherborn Street | Corona, CA 92879 | 800.343.7790 | imperialrange.com | imperialsales@imperialrange.com