



TWO COMPARTMENT 24 PAN STEAMER WITH CABINET BASE



COMPARTMENT PAN CAPACITY PER COMPARTMENT					
MODEL	PAN DEPTH				
	1"	2-1/2"	4"	4" & 1"	4" & 2-1/2"
GCX-24	24	12	8	4 x 4" 12 x 1"	4 x 4" 2 x 2-1/2"

Job # _____

SPECIFICATIONS:

Shall be a Crown model **GCX-24** convection steamer with gas steam boiler. The steamer shall be constructed of satin finish stainless steel, type 304, with a cooking chamber of one piece all welded 316 stainless steel. The doors shall have a removable inner liner of stainless steel with full perimeter gasket seal, an outer liner of one-piece all welded stainless steel and a positive lock and seal mechanism. The door opening shall be 17.625" x 26.75" (448 x 680mm).

The steamer shall be provided with removable stainless steel pan supports and a stainless steel drip trough connected to the drain to collect condensate when door is opened.

The control housing shall be constructed of stainless steel with a full access removable panel. The timing of each cooking compartment shall be independently controlled by a "60" minute timer, a green ready pilot light and a red cook pilot light. At the end of the cooking cycle an audible signal is sounded. Steam flow to the cooking chamber shall be interrupted when the door is opened during the cooking cycle and shall be reactivated when the door is closed.

The convection steamer shall be mounted on a cabinet base with full perimeter angle frame, reinforced counter, and boiler mountings, gas boiler with controls, all stainless steel exterior, hinged doors and 6" (152mm) stainless steel legs with 4 adjustable flanged feet for securing to the floor. Water treatment system, automatic blowdown, CSD-1 boiler controls, electronic ignition, and split water line are standard.

SEE REVERSE SIDE OF SPEC SHEET FOR WATER TREATMENT SYSTEM STATEMENTS

OPERATION SHALL BE BY:

Gas heated steam boiler, operating at 9-11 psi (62-76kPa) rated at 300,000 BTU.

The gas boiler shall be equipped to operation on:

- Natural gas
- Propane gas

The controls shall be equipped for operation on:

- 115 VAC, 1 Phase, 60 Hz

STANDARD FEATURES:

- Water Treatment System
- Automatic boiler blowdown
- Split water lines
- CSD-1 boiler controls
- Flanged feet

OPTIONAL ITEMS AT EXTRA COST:

- 220 or 240 VAC, 1 Phase, 50 Hz
- Stainless steel frame (SSF)
- Stainless steel back on cabinet (SSB)
- Load compensate timer
- Sheet pan support (SPS-24-1)

ACCESSORIES:

- Spray and rinse assembly
- Water in "Y" strainer
- Steam take off kit



MODEL	SHIPPING WEIGHT (36" CABINET)	MINIMUM CLEARANCE	
		SIDES BACK	0 0
GCX-24	990 lbs. [449 kg]		

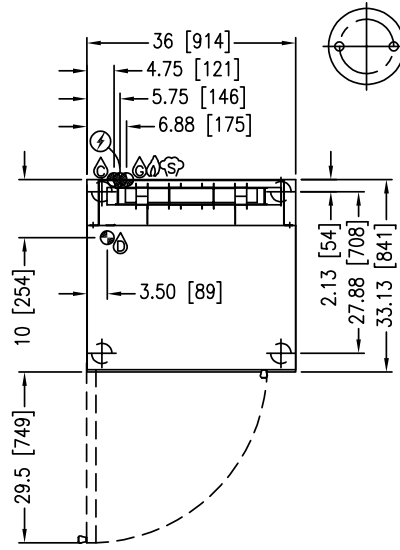
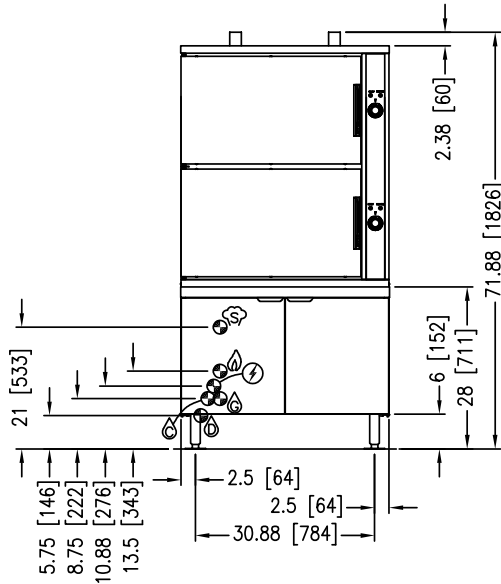

FLANGED FOOT DETAIL
 2 EQUALLY SPACED
 Ø7/16" [11mm] HOLES
 ON 2.5" [63mm] B.C.

IN [mm]

8816R1

SERVICE CONNECTIONS

- GENERATOR: COLD WATER: 1/2" NPT, 25-50 psi (170-345 kPa).
- CONDENSATE: COLD WATER: 1/2" NPT, 25-50 psi (170-345 kPa).
- DRAIN: 2" (51 mm) IPS piped to open floor drain. No solid connection.
- ELECTRICAL CONNECTION: 1/2" (13 mm) conduit connection to controls. 2 Amps per compartment, 120-60-1 or 220-50-1.
- STEAM TAKE-OFF CONNECTION: 3/4" (19 mm) optional to operate adjacent equipment.
- GAS CONNECTION: 3/4" (19 mm) IPS supply line required.

UTILITIES

MODEL	GAS SUPPLY			
	WATER COLUMN PRESSURE		BTU/HR	kW/HR
GCX-24	Natural	Propane	250,000	73.3
	min 4" (102 mm)	min 11" (279 mm)	300,000	87.9

WATER QUALITY STATEMENT

Water is the essential ingredient in steam equipment, water quality is the major factor affecting the performance of your appliance. Crown Steam Group offers a Comprehensive Water Treatment System which exceeds our minimum water requirements. Proof of installation and proper cartridges replacement is required for warranty coverage. Water supply to Crown Steam Group steamers must be within these guidelines.

- Total dissolved solids.....Less than 60 PPM
- Total alkalinityLess than 20 PPM
- Silica.....Less than 13 PPM
- ChlorineLess than 1.5 PPM
- pH Factor6.8 - 7.3

Water which does not meet these standards should be treated with the installation of Middleby's Water Treatment System. Call 919-762-1000 if you have questions concerning your water meeting these parameters.

*Failure or malfunction of this appliance due to poor water quality is not covered under warranty.

Reference www.crownsteamgroup.com for complete warranty details and instructions.

**INTENDED FOR COMMERCIAL USE ONLY.
 NOT FOR HOUSEHOLD USE.**



70 Oakdale Road, Toronto ON, Canada M3N 1V9
 (919) 762-1000 www.crownsteamgroup.com