



The Signature of Quality®

### FEDERAL INDUSTRIES

A Standex Company

215 Federal Avenue  
Belleville, WI 53508-9201

Phone: 800-356-4206  
Fax: 608-424-3234  
Email: geninfo@federalind.com  
Website: www.federalind.com

Project Name: \_\_\_\_\_

Item #: \_\_\_\_\_

Model #: \_\_\_\_\_ Qty: \_\_\_\_\_

Approval: \_\_\_\_\_

AIA#

SIS#

## UNDER COUNTER SL - Square End, Refrigerated, Self-Serve Display Case

Incorporate into your own counter to drive product sales. The under-counter merchandiser will entice customers with last minute impulse sales through visual appeal.



Shown with optional accessories



Counter not included

MODEL	DIMENSIONS ( Includes End Panels )
<input type="checkbox"/> UCRSL3633S	35.7 x 24 x 32.5 (in) 907 x 610 x 826 (mm)
<input type="checkbox"/> UCRSL4833S	47.7 x 24 x 32.5 (in) 1212 x 610 x 826 (mm)
<input type="checkbox"/> UCRSL6033S	59.7 x 24 x 32.5 (in) 1516 x 610 x 826 (mm)
<input type="checkbox"/> UCRSL7233S	71.7 x 24 x 32.5 (in) 1821 x 610 x 826 (mm)

### STANDARD FEATURES

#### Model Features

- Black interior
- Squared ends with mirrored liner
- Black top
- Black 1 step riser
- Black powder coated steel base
- Black exterior. Other finishes optional
- Light and power switch on back of case
- Front access to refrigeration system for quick and easy service
- Cord & plug
- Recessed casters with adjustable leg lever

#### Refrigeration

- On-Demand PTC condensate evaporator provided for a totally self-contained system
- Electronic temperature controls maintain 38° - 40°F
- Easy clean, rustproof insulated evaporator coil compartment
- Rear condensing unit air intake & discharge
- R290 Refrigerant
- Thermometer

#### Lighting

- 3500 LED top light

#### Agency Approvals

- UL, C-UL and UL Sanitation listed to NSF-7, Type I conditions
- DOE 2017 compliant

### OPTIONAL ACCESSORIES

- White or stainless interior (Including step riser or shelf)
- Glass, stainless steel, white or black solid shelf w/ LED light
- Special exterior finish
- Energy saving night curtain
- Security night cover
- Condensate pump
- 6" Legs
- 4" Casters
- Rear air intake, front discharge



**WARRANTY\***  
One year Parts and Labor  
2nd thru 5th year part  
only service compressor  
(U.S.A and Canada)



Note: Information is subject to change at any time. Visit [www.federalind.com](http://www.federalind.com) for the most current specs.

AIA#

# UNDER COUNTER SL - Square End, Refrigerated, Self-Serve Display Case

SIS#

## Product Specifications

Intended Environment: Type I - Designed to operate in maximum ambient conditions of 75°F (24°C) and 55% relative humidity.

Zone	Intended Product To Be Displayed	Avg Prod Temp °F/°C
All	Packaged Refrigerated Products	38°F / (3.3°C)

DIMENSION: xx"/(mm)  
 DIMENSION TOLERANCE +/- 0.25 (6.4)

SYMBOL KEY:  
 ELECTRICAL JUNCTION BOX (SUPPLIED W/6 LEADS OR POWER CORD)

 TUB DRAIN LOCATION

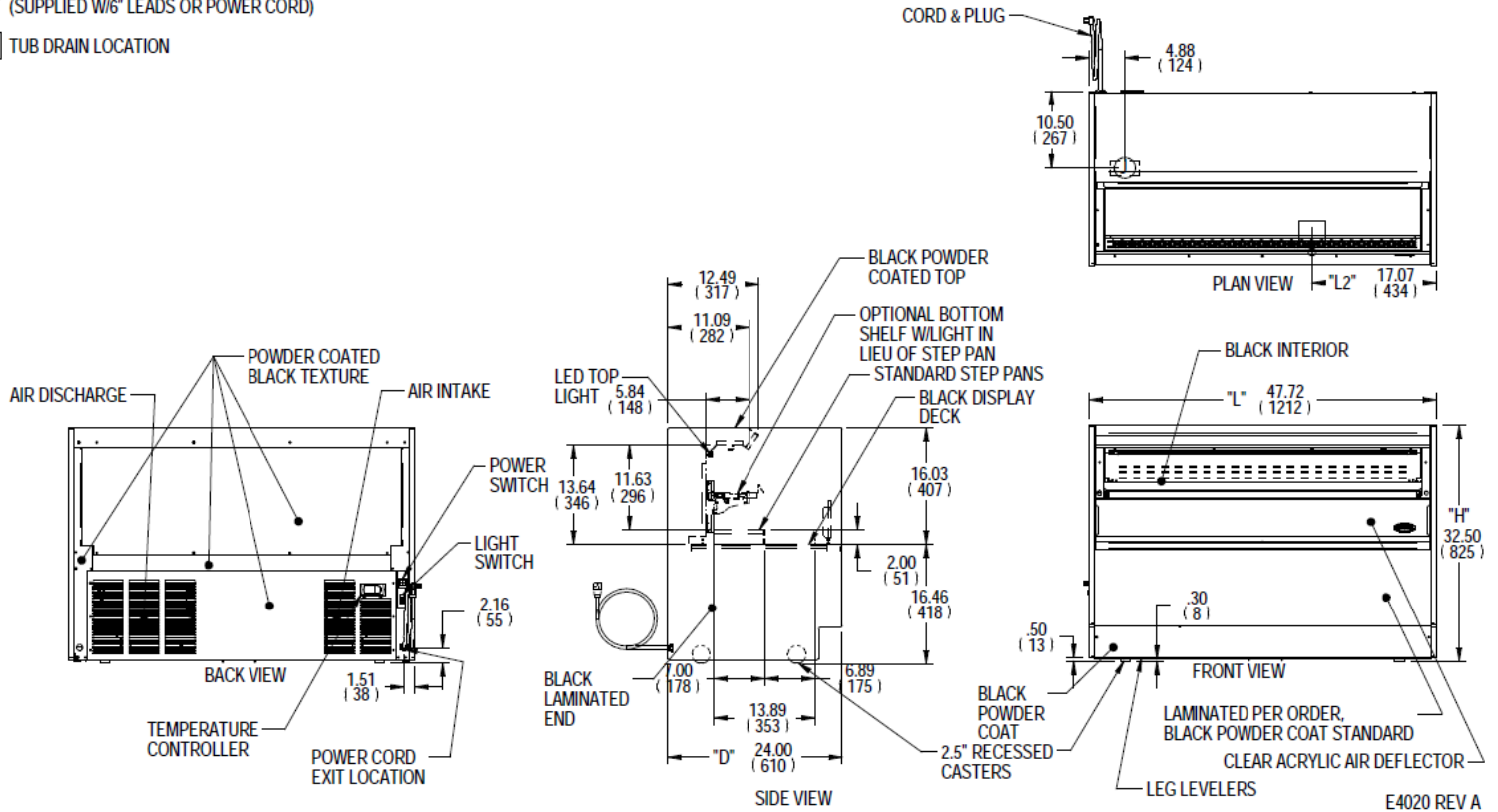

MODEL	DIMENSION			TUB DRAIN	STEP RISER	INTERIOR VOLUME CU FT	ELECTRICAL	STANDARD CONNECTION			REFRIGERANT	CONDENSATE REMOVAL	SHIP WEIGHT	
	L	D	H	L2	# OF STEPS			CORD & PLUG						
	in	in	in	in				2-WIRE + GROUND	AMPS	MAX FUSE SIZE				NEMA CORD & PLUG
	mm	mm	mm	mm				mm	mm					
UCRSL3633S	35.7	24.0	32.5	8.01	1	7.00	120/60/1	10.0	15	5-15	R290	CONDENSATE PAN	365 LBS	
	907	610	826	203		178							853	166 KILO
UCRSL4833S	47.7	24.0	32.5	17.01	1	7.00	120/60/1	10.0	15	5-15	R290	CONDENSATE PAN	495 LBS	
	1212	610	826	432		178							1158	224 KILO
UCRSL6033S	59.7	24.0	32.5	22.01	1	7.00	120/60/1	16.0	20	5-20	R290	CONDENSATE PAN	620 LBS	
	1516	610	826	559		178							1463	281 KILO
UCRSL7233S	71.7	24.0	32.5	28.01	1	7.00	120/60/1	16.0	20	5-20	R290	CONDENSATE PAN	750 LBS	
	1821	610	826	711		178							1768	340 KILO

- Case temperature will vary if the air curtain is disrupted.
- Due to continuing engineering improvements, specifications are subject to change without notice.



**FEDERAL INDUSTRIES**  
 A Standex Company  
 215 Federal Avenue Belleville, Wisconsin 53508-9201

**Phone:** 800-356-4206  
**Fax:** 608-424-3234  
**Email:** Geninfo@Federalind.com  
**Website:** Federalind.com