



Project _____
 AIA # _____ SIS # _____
 Item # _____ Quantity _____ C.S.I. Section 114000



HL662 LEGACY+ 60-Quart Maximum Heavy-Duty Pizza Mixer



SPECIFIER STATEMENT

Specified mixer will be an NSF rated 60-quart maximum heavy-duty, all-purpose mixer with Hobart PLUS System, two fixed agitator speeds. Mixer has 2.7 HP output at the planetary shaft and gear transmission. Features include automatic time recall, swing-out bowl, Shift-on-the-Fly™ controls, power bowl lift and FastStop™ technology that stops rotation within 3 seconds. Mixer finished with a metallic gray hybrid powder coat and has a NoChipMAX™ system with aluminum planetary, attachment hub with stainless steel insert, yoke and feet covers, and stainless steel bowl guard.

MODEL

HL662 60-Quart Maximum Heavy-Duty Pizza Mixer

STANDARD FEATURES

Features in bold are exclusive to Hobart

- + **PLUS System**
 - **VFDadvantage** variable frequency drive
 - **Maximum capacity** overheat protection
 - **Reinforced planetary shaft system**
- + **NoChipMax™ System**
 - **NoChip™ aluminum planetary** with heat-treated metallic burnished finish
 - **#12 taper attachment hub with stainless steel insert and dye-cast cover**
 - **Yoke and feet covers**
- + **Triple interlock system with MagnaLock technology**
- + Heavy-duty 2.7 HP motor
- + Gear transmission
- + Two fixed agitator speeds
- + **Shift-on-the-Fly™ controls**
- + Soft start agitation technology
- + **20-minute SmartTimer™**
- + Automatic time recall
- + Large, easy-to-reach controls
- + **Single point bowl installation**
- + **Ergonomic swing-out bowl**
- + Power bowl lift
- + Open base
- + Stainless steel removable bowl guard
- + **FastStop™ interlock**

ACCESSORY PACKAGE

Featuring Hobart Quick Release™ Agitators

- HL662-1STD Standard Pizza Accessory Package includes:
 - + 60-quart stainless steel bowl
 - + 60-quart “ED” dough hook

HL662 LEGACY+ 60-QUART MAXIMUM HEAVY-DUTY PIZZA MIXER

Approved by _____ Date _____ Approved by _____ Date _____



HL662 LEGACY+ 60-Quart Maximum Heavy-Duty Pizza Mixer

SOLUTIONS/BENEFITS

PERFORMANCE

VFDadvantage Variable Frequency Drive

- + Direct drive system
- + Ensures superior mixing consistency, motor protection and long life

Quick Release™ Agitators

- + Eliminates the up/down play of bayonet-style agitators
- + Consistent agitator-to-bowl ratio delivers superior mixing performance

Two Fixed Agitator Mixing Speeds

- + Supports consistent results, thorough kneading
- + Ideal for pizza dough

Reinforced Planetary Shaft System

- + Rugged durability under the most challenging mixing conditions

Maximum Capacity Overheat Protection

- + Extreme-duty wiring and connections handle more power, reducing thermal cycling impact

EASE OF USE

Ergonomic Swing-Out Bowl

- + Easily swing bowl to the side to remove/add ingredients
- + Adds convenience and saves time

Single-Point Bowl Installation

- + Easy-to-mount bowl uses only one point to install
- + Reduces risk of spills, speeds up mixing process

Power Bowl Lift

- + Electronic, smoothly moves bowl into mixing position

Shift-on-the-Fly™ Controls

- + Allows safe, convenient speed changes while the motor is running
- + Pulse and jog as needed

20-Minute SmartTimer™

- + Automatic recall of time and speed

SANITATION & CLEANING

NoChip™ Aluminum Planetary

- + Prevents paint chipping

NoChip™ #12 Taper Attachment Hub with Stainless Steel Insert and Dye-Cast Cover

- + Prevents paint chipping

NoChip™ Yoke and Feet Covers

- + Prevents paint chipping

Stainless Steel Removable Bowl Guard

- + Easy to remove without tools for cleaning
- + Dishwasher-safe for easy cleaning and sanitizing

Soft Start Agitation Technology

- + Gradually delivers electricity to the mixer
- + Minimizes the risk of ingredient splash out

OPERATOR ASSURANCE

Triple Interlock System with MagnaLock Technology

- + Prevents mixer from operating unless the bowl is fully up and locked in place and the bowl guard is secured

FastStop™

- + VFDadvantage brings all moving parts to a complete stop in less than 3 seconds

HL662 MIXER CAPACITY CHART

Recommended Maximum Capacities – dough capacities based on 70°F water and 12% flour moisture.

Product	Agitators Suitable for Operation	HL662
Capacity of Bowl (Qt. Liquid)		60
Egg Whites	D	2 qt.
Mashed Potatoes	B & C	40 lb.
Whipped Cream	D or C	12 qt.
Cakes		75 lb.
Cookies, Sugar		50 lb.
Dough, Bread or Roll ★ (Lt.-Med.) 60% AR	ED	90 lb. ■
Dough, Heavy Bread 55% AR ★	ED	85 lb. ■
Dough, Thin Pizza 40% AR ★ (max. mix time 5 min.)	ED	60 lb. ● 40 lb. ■
Dough, Thick Pizza 60% AR ★	ED	90 lb. ■
Dough, Whole Wheat 70% AR	ED	90 lb. ■
Icing, Fondant	B	36 lb.
Icing, Marshmallow	C or I	5 lb.
Pasta, Basic Egg Noodle (max. mix time 5 min.)	ED	40 lb. ●

Note: % AR (% Absorption Ratio) – Water weight divided by flour weight. Capacity depends on moisture content of dough. Above capacities based on 12% flour moisture at 70°F water temperature.

● 1st Speed

■ 2nd Speed

▲ 3rd Speed

★ If high gluten flour is used, reduce above dough batch size by 10%.

2nd speed should never be used on 50% AR or lower products.

Use of ice requires a 10% reduction in batch size.

1 gallon of water weighs 8.33 lbs.

Note: Attachment hub should not be used while mixing.



HL662 LEGACY+

60-Quart Maximum Heavy-Duty Pizza Mixer

SPECIFICATIONS

Motor: 2.7 HP high torque motor.

Electrical: 200-240/50/60/1; 18.0 amps, 200-240/50/60/3; 8.0 Amps, 380-460/50/60/3; 4.0 amps - UL Listed.

Controls: Magnetic contactor and thermal overload protection. Internally sealed "Start-Stop" and Power Bowl Lift push buttons. Reduced voltage pilot circuit transformer is supplied for 380-460/50/60/3 machines. A 20-minute SmartTimer™ is standard. SmartTimer™ includes:

- **Automatic Time Recall**, which remembers the last time set for each speed.
- **Transmission:** A rated 5.4 HP poly-V belt transfers power from motor to input shaft then geared down to desired reduction with a constant gear mesh. Gears and shafts are heat-treated hardened alloy steel along with anti-friction ball bearings. Circulating oil and grease lubricants furnished to all gears and shafts.

Speeds	Agitator (RPM)	Attachment (RPM)
First	56	111
Second	99	196
Grind Meat		212
Cheese Shred		355
Vegetable Slice		700

Bowl Guard: Heavy-duty stainless steel wire front and solid rear portion. Front portion of guard rotates easily to add ingredients and install or remove agitator. It detaches in seconds for cleaning in dishwasher or sink. Rear portion of guard can be quickly cleaned in position. Guard must be in closed position before mixer will operate. Bowl support interlock provides further protection.

Power Bowl Lift: Powered by an electric motor, the bowl may be raised or lowered by fingertip control through the conveniently located switch. Bowl will remain in position until switch is activated.

Stir-on-Lift Feature: Allows the agitator to run in Stir Speed while the mixer bowl is being raised. Once the bowl is in the raised position, the mixer automatically shifts into the preselected speed.

Finish: Metallic gray hybrid powder coat finish.

Footpads: Neoprene footpads are standard.

Attachment Hub: Comes with front-mounted Hobart standard #12 taper attachment hub for use with Hobart #12 size attachments.

Attachments and Accessories:



The following are available at extra cost:

Attachment / Accessory	Device #
Stainless Steel Bowl	BOWL-HL60
"B" Flat Beater	BBEATER-HL60
"C" Wing Whip	CWHIP-HL60
"D" Wire Whip	DWHIP-HL60
"ED" Dough Hook	EDDOUGH-HL60
"E" Dough Hook	EDOUGH-HL60
"P" Pastry Knife	PPASTRY-HL60
"I" Heavy Duty Wire Whip	IWIRE-HL60
Bowl Splash Cover (lexan)	SPLASH-LEX060
Bowl Scraper**	SCRAPER-HL60**
Bowl Scraper	SCRAPER-HL60AP
Bowl Scraper, 40-Qt. Bowl**	SCRAPER-HL640**
Bowl Scraper, 40-Qt. Bowl	SCRAPER-HL64AP
Ingredient Chute	CHUTE-HL
Bowl Truck	TRUCK-HL1486
Bowl Extension Ring	EXTEND-SST60G
Deck Plate	DECK-LEG60
9" Vegetable Slicer	VS9
Meat Chopper Attachment	12TIN-C/EPAN
Additional 40 Quart Accessories	See HL400 spec sheet

**These scrapers are only for use with 60-qt. mixers with a serial number BEFORE #311681285

Plugs and Receptacles:

Hobart recommends that your machine be hardwired to the power source for optimal performance. Refer to the data plate on your machine and local power codes; cords not provided.

Machine Voltages			
HL662	200-240	200-240	380-460
Service Current Requirement if Plug Connected	200-240/50/60/3/1	230/60/3	460/60/3
	20 Amp.	20 Amp.	20 Amp.
Terminal Designation of Plug		3 Pole 4 Wire Grounding	3 Pole 4 Wire Grounding
NEMA Plug Configuration		L15-20P	L16-20P
Plug Configuration			
Molded Plug on Cord		No	No
Plug - Straight/Angle		Straight	Straight
NEMA Receptacle or Connector Configuration		L15-20R	L16-20R
Power Cord Included	No	No	No



HL662 LEGACY+ 60-Quart Maximum Heavy-Duty Pizza Mixer

SPECIFICATIONS

Electrical: 200-240/50/60/1, 200-240/50/60/3 and 380-460/50/60/3 – UL Listed.

Weight: Net – 866 lbs.; Shipping – 916 lbs.

Warranty: Unit has full one-year warranty on parts, labor and mileage against manufacturer's defects. Service contracts are available.

DETAILS AND DIMENSIONS

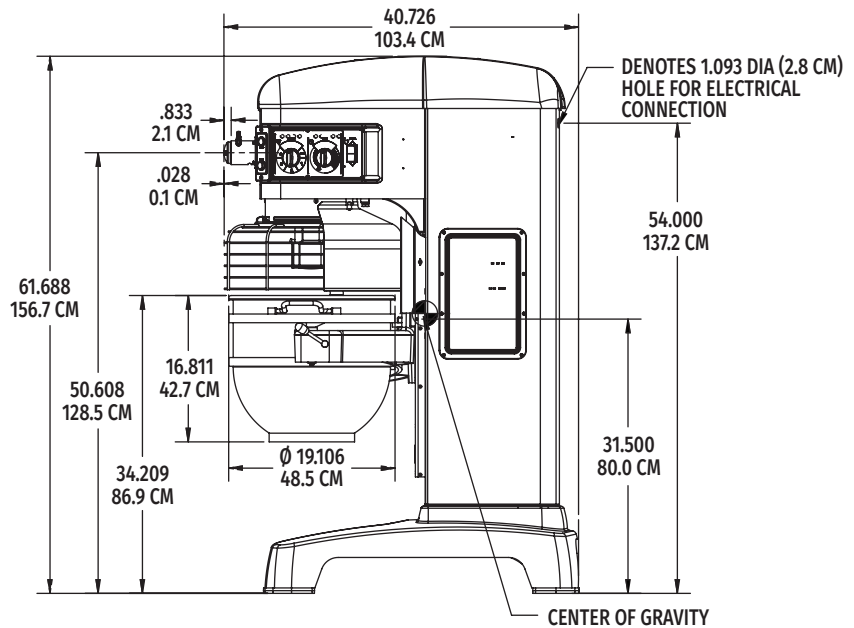
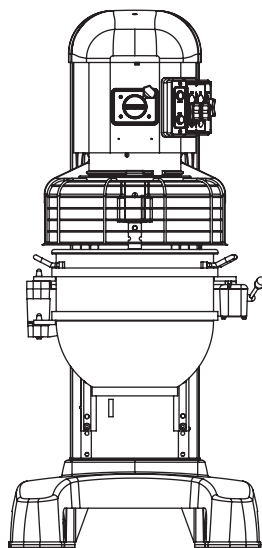
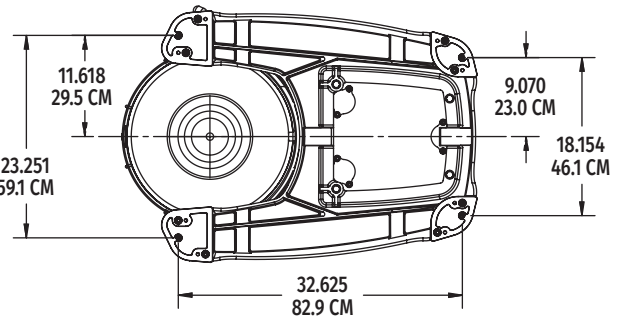
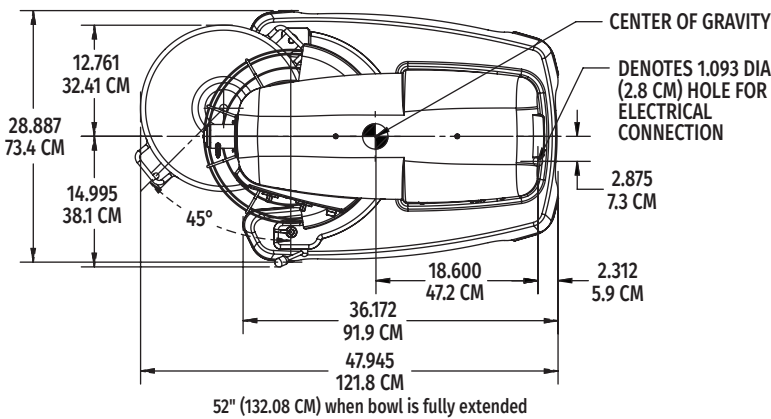

WARNING: Electrical and grounding connections must comply with the applicable portions of the National Electrical Code and/or other codes in force.

NOTE:
Net Weight (Bowl Included): 905 lbs. (411.4 kg)
Domestic Shipping Weight (Bowl Included): 955 lbs. (434.1 kg)
Bowl Weight: 39 lbs. (17.7 kg) - Ref