

REACH-IN FREEZER (0°F)

Model: 1FENPT

Natural Refrigerant R-290 Model

1-Section Extra-Wide Pass-Thru Freezer

- 1FENPT** - Stainless steel front, aluminum end panels and interior
- 1FENSAPT** - Stainless steel exterior, aluminum interior
- 1FENSSPT** - Stainless steel exterior and interior



Options and Accessories

(upcharge and lead times may apply)

Additional epoxy coated steel shelves	Hinged glass doors (consult factory)
Chrome or stainless steel shelves	Half door(s)
Wine rack	Rehinging of doors (consult factory)
Universal pan slides	Correctional Facility Options
Adjustable legs	<ul style="list-style-type: none"> • One way security screws
Custom laminates	<ul style="list-style-type: none"> • Locking hasp (lock not included)
Special electrical requirements (consult factory)	<ul style="list-style-type: none"> • Stainless steel mesh cover • Coverless hinges

Consult factory for other model configurations, options and accessories.

Continental[®]
Refrigerator



Project Name:

Model Specified:

Location:

Item No:

Quantity:

AIA #:

SIS #:

Standard Model Features

REFRIGERATION SYSTEM

Self contained, performance rated "plug" refrigeration system

Natural, environmentally safe, high efficiency R-290 refrigerant¹

Refrigeration system is readily accessible on top of cabinet, separate from the "food zone"

Automatic, hot gas condensate evaporator

Expansion valve system

CABINET ARCHITECTURE

3" non-CFC polyurethane foam insulation

Smooth, polished chrome workflow door handle

Cam action, lift off hinges

Self-closing door

Magnetic snap in Santoprene™ door gasket

Cylinder lock in door

Heavy duty, epoxy coated steel shelves

Heavy duty pilaster strips

5" casters

MODEL FEATURES

LED interior lighting

Electronic control, automatic electric defrost

Top and side air distribution ducts

Cabinet upper side panels and refrigeration "plug" system can be removed and reinstalled at job site

¹ R-290 refrigerant meets all federal and state regulatory requirements.

APPROVAL:

Model Specifications

DIMENSIONAL DATA

Net Capacity (cubic feet)	22 (623 l)
Width, Overall (inches)	28 1/2 (724 mm)
Depth, Overall (inches) (including handles)	38 3/4 (984 mm)
Depth (inches) (less doors)	32 (813 mm)
Depth (inches) (doors open 90°)	84 (2134 mm)
Clear Door Width (inches)	21 7/8 (556 mm)
Clear Door Height (inches)	58 5/8 (1489 mm)
Height, Overall (inches) (including 5" casters)	82 1/4 (2089 mm)
Number of Doors	2
Number of Shelves	3
Shelf Area (square feet)	20.4 (1.9 sq m)
Tray Slide Capacity (2" centers)	24

REFRIGERANT DATA

Condensing Unit Size (H.P.)	1/2
R-290 Refrigerant Charge (oz)	4.3
Capacity (BTU per hour)*	1980

ELECTRICAL DATA

Voltage (International)	115/60/1 (220/50/1)
Feed Wires (including ground)	3
Total Amps (International)	6.0 (3.0)
Defrost Amps (International)	4.4 (2.2)
10 ft. Cord/Plug [attached] (International)	Yes (No)

SHIPPING DATA

Height - Crated (inches)	85 1/2 (2172 mm)
Width - Crated (inches)	31 5/8 (803 mm)
Depth - Crated (inches)	42 (1067 mm)
Volume - Crated (cubic feet)	65 (1841 cu l)
Weight Std - Crated (pounds)	370 (168 kg)
Weight SS - Crated (pounds)	445 (202 kg)

* Rating @ -15°F evaporator, 90°F ambient
 Figures in parentheses reflect metric equivalents rounded to the nearest whole unit.

Model Plan Views

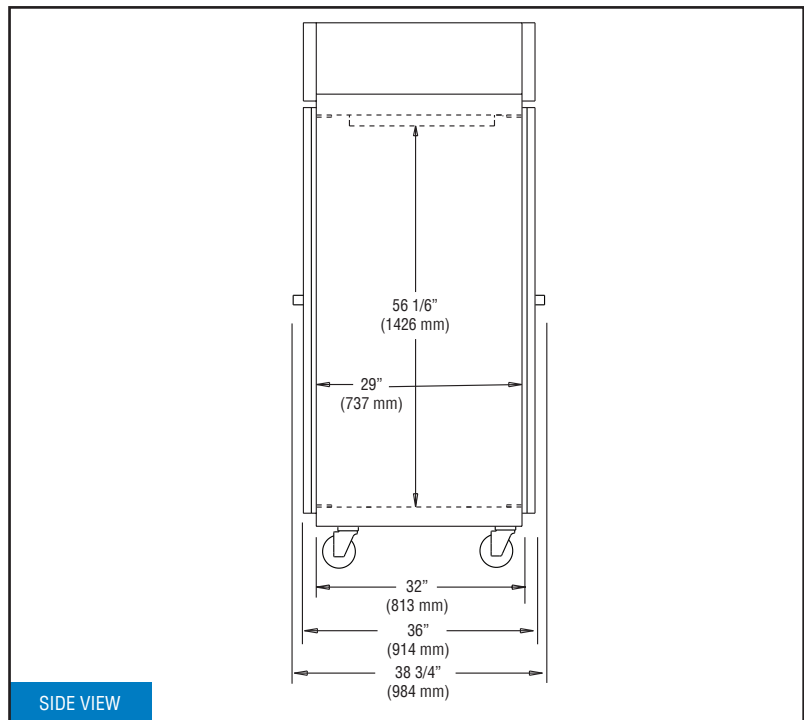
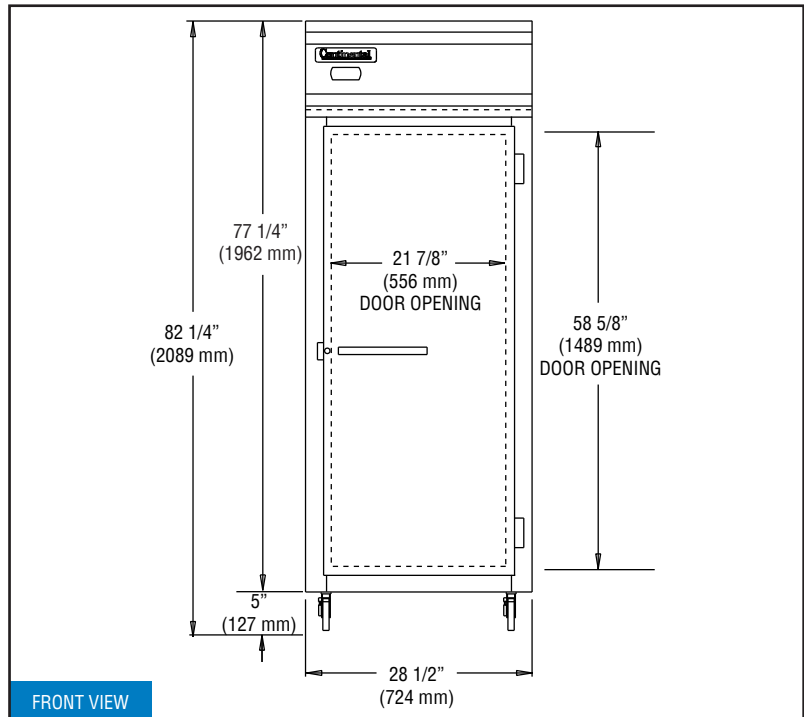

IMPORTANT NOTE: If the cabinet is located under a low ceiling, a minimum clearance of 12" is required on top and 3" on sides.



Toll-Free: 800-523-7138
 Phone: 215-244-1400
 Fax: 215-244-9579

539 Dunksferry Road
 Bensalem, PA 19020
www.continentalrefrigerator.com

Due to our continued efforts in developing innovative products, specifications subject to change without notice.



PROUDLY
 DESIGNED & ASSEMBLED
 IN THE U.S.A.

Intertek

© Copyright 2021. Continental Refrigerator.
 A Division of National Refrigeration & Air Conditioning Products, Inc.



Equipped with one NEMA-5-15P Plug
 (varies by country)

REVISED: 1/30/25