



# HAND BLENDER XM-31V 120/50-60/1

Professional immersion blender. 0.54 Hp / 400 W.



P/N. 3030863



✓ Approved by NSF: guaranteed safety and hygiene.

## INCLUDES

- ✓ Variable speed motor block.
- ✓ MA-31 mixer arm.
- ✓ Wall mount.

## OPTIONS

- MA-32 mixer arm.
- MA-33 mixer arm.
- Whisk.
- "Quick fix" clamp.
- Clamp sliding frame.

## ACCESSORIES

- Motor unit MM-30V

## SPECIFICATIONS

Total loading: 0.54 Hp / 400 W  
 Maximum recipient capacity: 32 qt  
 Motor speed: 1500 - 12000 rpm  
 Blade diameter: 2.17"  
 Blade guard diameter: 3.6"  
 Electrical supply: 120 V / 50-60 Hz / 1~ (3.5 A)  
 Plug: USA (NEMA 5-15P / 2P+G)

### Length

Liquidising arm length: 12.05"  
 Total length: 24.17"

Net weight: 7.36 lb  
 Noise level (1m.): <80 dB(A)

### Crated dimensions

17.9 x 18.7 x 4.6 "  
 Gross weight: 9.3 lbs.

## SALES DESCRIPTION

- ✓ Variable speed motor block.
- ✓ 12.05" detachable arm.
- ✓ Designed for continuous use in recipients of up to 32 qt.

### All-in-one

- ✓ Professional hand blender designed for carrying out different preparations without the need for add-on tools.
- ✓ Professional Y-blade, made from tempered steel and with a long-duration cutting edge.
- ✓ Adjustable speed.
- ✓ Designed to work in recipients of up to 30 litres.

### Maximum comfort for the user

- ✓ Compact design: logical and manageable size.
- ✓ Ergo-design & bi-mat-grip: external casing made in two materials for an ergonomic hold. Anti-slip grip. Optimum inclination of handle, minimising fatigue.
- ✓ Click-on-arm: detachable arm with fast and secure closure.
- ✓ Hood designed to avoid splashes.
- ✓ Intuitive use: very simple operation. LED warning light in two colours to indicate the status of the machine.
- ✓ Possibility of continuous operation.

### Built to last

- ✓ Professional performance: capable of carrying out prolonged work without the casing overheating.
- ✓ Life-plus: equipped with a motor which has passed all of the most demanding usage tests.
- ✓ Studied geometry: casing designed to avoid rolling and falling.
- ✓ Easy to clean: detachable arm, can be cleaned under the tap.



DYNAMIC PREPARATION  
COMMERCIAL HAND BLENDERS

product sheet  
updated 05/16/24



# HAND BLENDER XM-31V 120/50-60/1

Professional immersion blender. 0.54 Hp / 400 W.



P/N. 3030863

DYNAMIC PREPARATION  
COMMERCIAL HAND BLENDERS

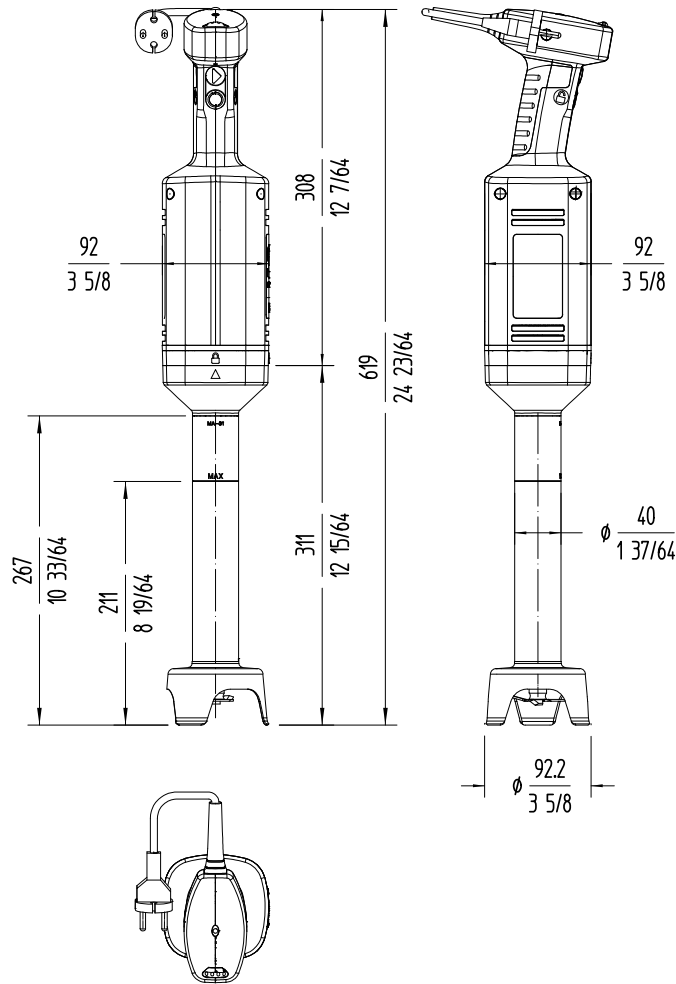

**sammic** | www.sammic.us  
Food Service Equipment Manufacturer

usa@sammic.com  
1225 Hartrey Avenue  
60202-1056 Evanston, IL

phone +1 (224) 307-2232  
toll free +1 844 275 3848



Project	Date
Item	Qty
Approved	

product sheet  
updated 05/16/24