

Champion[®]

The Dishwashing Machine Specialists

PROJECT: _____

ITEM # _____ QTY: _____

MODEL # _____

AIA # _____ SIS # _____

UH 330 ADA

ADA UNDERCOUNTER HIGH TEMPERATURE



Rendered image is for general visual representation only. Please refer to specifications for the latest detailed product information.

OPTIONS & ACCESSORIES

- Additional Dish Racks
 - Peg
 - Flat
- 17" Stand Stainless Steel
- 4.5" Stand (converts to a standard counter height)
- 8" Leg Stand
- 3 Phase Connection (prewired at factory)
- 1" Roller Kits available (includes 4 casters)
- Drain Water Tempering Kit (unmounted)
- Power Cord Kit
- Chemical alarm kit (mounted)
- Door interlock switch (mounted)

STANDARD FEATURES

- **Space Saving 29-7/8" Height**
fits easily under the thickest countertops – allowing for 34" ADA requirements
- **12" Internal Clearance**
- **Heat Recovery:**
Cold water feed only! Up to 50% more energy efficient! Quicker drying of wares! Condensation is removed! Reduced operating costs!
- **Dry Assist**
provides improved and quicker drying of wares
- **Multi-Cycle**
3 cycle time options for enhanced cleaning
- **Insulated Booster**
- **StemSure**
Soft start to protect glasses and dishes from chipping and breaking
- **Simple Field Conversion From Single To Three Phase**
- **Precise Digital Temperature Display And Control**
- **ENERGY STAR[®] Qualified**
- **Rinse Sentry**
ensures 180°F/ 82°C final rinse for sanitized wares
- **Standard Liquid Detergent And Rinse-Aid Pumps**
- **Advanced Service Diagnostics**
- **Pumped Drain**
- **Automatic Drain Cycle**
- **1 HP Corrosion Resistant Pump**
- **316 Stainless Steel Tank**
for improved corrosion resistance, an industry exclusive
- **Independent Stainless Steel Interchangeable Upper And Lower Wash And Rinse Arms**
- **Includes Two Racks**
1 peg and 1 flat

SPECIFIER STATEMENT

Specified unit will be only 29-7/8", 12" internal clearance high temperature undercounter dishwasher operating on a 1/2" cold water supply only with heat recovery. Unit shall incorporate a "dry assist" feature to improve and speed-up the drying of wares. Features selectable 120, 200 and 277 second cycle times, 3 time cycle options, LED temp display, Rinse Sentry, rinse aid and detergent pumps, flexible fill and drain hoses, stainless steel top and side panels. Constructed of stainless steel.

1 year parts and labor warranty.

Note: Vent hood is not recommended, as unit does not produce excessive steam.

Note: Always follow local building code guidelines.



In the USA:

3765 Champion Blvd, Winston-Salem, NC 27105
Tel: (336) 661-1556 Fax: (336) 661-1979
www.championindustries.com

In Canada:

2674 N. Service Rd., Jordan Station, Ontario, Canada LORISO
Tel: (905) 562-4195 Fax: (905) 562-4618
www.championmoyerdiebel.ca

SPECIFICATIONS

Capacities

Cycle time (seconds) 150/200/277
Racks per hr. 24/18/13

Motor Horsepower

Wash 1

Water Consumption

U.S. Gal (max. use) per hr. 15.6/12.9
U.S. Gal. per rack 0.65/.54

Temperature °F/°C

Wash 150/66
Rinse 180/82

Heating

Tank heat, electric, (kW) 2.0
Electric booster, (kW) 4.3

Time Cycle in seconds

Wash 45/120/197
Rinse 13
Heat Recovery/condense 62

Standard 20" x 20" Rack Complement

Dish 1
Open 1

UH330 with Booster

Elec. Specs	Rated Amps	Minimum Supply Ckt. Conductor Ampacity	Maximum Overcurrent Protective Device
208-240/60/1	32-36	40	40
208-240/60/3	22-24	30	30

Field convertible to accept 3 phase power

Utilities

- Electrical**
208-240/60/1; 3 wire plus ground, (See box).
208-240/60/3; 4 wire plus ground, (See box).
Field convertible to accept 3 phase power, see service manual for details
- Cold Water**
1/2" supply; 55-80°F [12-26°C] cold water; 25 PSI min.
Machine equipped with 3/4" [19] garden hose connector.
- Pumped Drain**
5/8" [15.9] I.D. flexible reinforced hose, 6 ft. [1829] long.
Max. drain flow 15 US gpm. [12.5 imp gal] Max. drain height 3 ft. [914]

Warning: Plumbing, electrical connections should be made by qualified personnel who will observe all the applicable plumbing, sanitary and safety codes and the National Electrical Code.

Plumbing Notes: Because of the variation in house-supplied steam and water pressures, steam and water pressure regulating valves (PRVs) may be needed. (Water PRV is standard on machines with booster.) The PRVs can either be purchased from Champion or obtained locally.

Champion does not endorse using on-demand (tankless) water heating systems, as well as PEX and other plumbing materials that may limit water flow, as these could impair machine performance. For optimal results, we recommend using appropriately sized conventional hot water tanks and standard copper water supply lines that adhere to our specifications. Not following these recommendations may void the manufacturer's warranty.

Water hardness of 3 grains/US Gal (0.83 Imp Gal) - 5.3 Mg/L or less

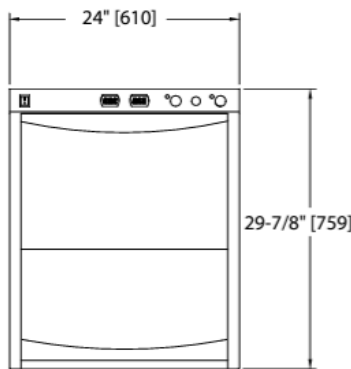
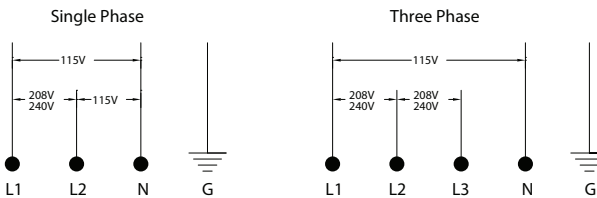

Front View

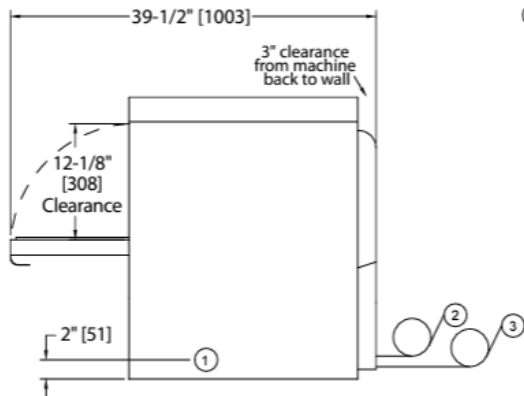

Side View

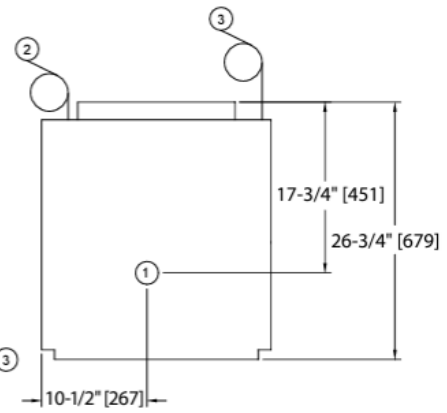

Plan View

In the USA: 3765 Champion Blvd, Winston-Salem, NC 27105 | Tel: (336) 661-1556 Fax: (336) 661-1979 | www.championindustries.com

In Canada: 2674 N. Service Rd., Jordan Station, Ontario, Canada LORISO | Tel: (905) 562-4195 Fax: (905) 562-4618 | www.championmoyerdiebel.ca