



Project Name: _____ AIA#: _____

Model #: _____ Location: _____

SIS#: _____ Item #: _____ Quantity: _____

ERGO100VL5

100 qt. Mixer

Ergonomic, automatic, hygienic and innovative, the ERGO is leading the industry in every way.

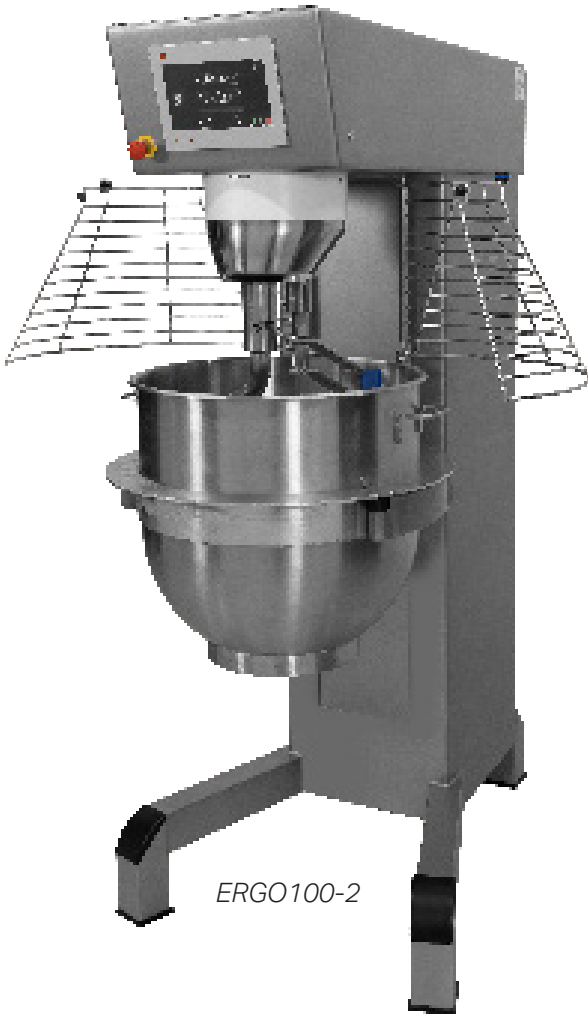

ERGO100-2

ITEM NUMBERS

- ERGO100-2 -208-240V 100 qt. Mixer
- ERGO100-2IP54 -208-240V 100 qt. Mixer with IP54

STANDARD FEATURES

- 5 HP motor with frequency converter
- Geared planetary transmission
- Variable frequency drive/converter
- Four fixed speeds with variable speed intervals ranging from 46 RPMs and 259 RPMs
- Stir speed button gently mixes at 20 RPMs
- Quick Shift technology enables shifting speeds while mixing
- Stir-on-lift function incorporates tool as bowl is lifted
- Large touch display with programmable features, multiple language options, error diagnostics and usage logs
- Program up to 24 multi-step recipes; time, speed, pause, bowl lowering with favorite buttons for quick start option
- 90-minute digital timer
- USB data import and export
- Option to downsize bowls without adapters
- Power bowl lift with self-aligning bowl arms
- Automatic bowl lowering
- Ability to remove bowl without removing agitators
- Stainless-steel frame construction
- **IP53** models are water and dust-resistant body, able to be hosed down at a 60° or lower angle
- **IP54** upgrade available with waterproof and dust-resistant body, able to be hosed down from any angle
- Permanently lubricated planetary head
- Dishwasher safe removable bowl guard
- Interlock prevents operation if guard is opened or bowl is lowered
- Emergency stop and overload protection
- 6-foot power cord
- ETL and NSF listed
- Made in Denmark

Ingredient chute and bowl truck included. Bowl and agitators not included. Choose from list of accessories to customize your package.

WARRANTY

- Four year parts and labor warranty, 1 year accessories

Approved by: _____

Date: _____



AutoQuotes

FEATURES & BENEFITS

"Strong as a Bear"

- 5 H.P. Motor
 - Heavy-duty design to meet the most demanding operations
 - Variable frequency drive converter allows for more efficient mixing
- Gear Transmission
 - Durable geared transmission with heavy-duty poly-v belt for variable speed and quick shift
 - Ensures consistent performance

Ergonomic

- User-focused design for a better mixing experience and productivity
- Optimal working height, operators benefit from a comfortable posture
- Change mixing tools from an upright position, no need to bend over or strain the back
- Self-aligning bowl reduces the need for heavy lifting, automatically adjusting the bowl into position when raising, and releasing the bowl when lowering
- Optional MaxiLift Electronic Bowl Lift easily transports and empties heavy batches with 180° bowl rotation

Automatic

- Customize multiple steps with mixing time and speed, pauses and bowl lowering for an automated mixing process
- Program recipes once and copy them onto other ERGO mixers by a simple USB import

Efficient

- Quickly change bowls without removing the mixing tool for faster production and uninterrupted workflow
- Fast bowl lowering, easy bowl removal and automatic bowl alignment streamline productivity for multi-batch sequences, saving time and operator energy
- When a new batch is started, the tool auto incorporates into the mix as the bowl is raised, reducing strain on the bowl-raising mechanism
- Four preset speeds, 15 speed intervals or use exact speed selection in recipe programming

Innovative

- Intuitive controls, the only touchscreen display of its kind – powerfully informative and simple to use
- Easy visibility at a distance, programmable multi-step recipes, multiple language options and on-screen error diagnostics
- Operators can mix manually with preset or varied speed settings, or customize multistep recipe programs for repeatable results

Hygienic

- Easy to clean surfaces, removable bowl guards and a fully stainless steel frame
- All food contact points can be removed for cleaning and sanitation
- Water and dust resistant body, able to be hosed down at a 60° or lower angle, waterproof internal components, USB port & display screen (IP53)
- Upgradable to waterproof and dust resistant body, able to be hosed down from any angle, waterproof internal components, USB port & display screen (IP54)

Simplified Maintenance

- On-screen diagnostics for faster service and reduced downtime
- USB data export preserves machine history and enables duplication across multiple machines
- Maintenance-free permanently lubricated bowl lift mechanism

Bowl Guard

- Wing style removable bowl guards allows visibility into the bowl and remove easily for cleaning
- Solid bowl guard option minimizes splash out

Auto Bowl Lift

- Stir-on-lift incorporates ingredients as the bowl is raising
- Bowl is raised by dual buttons requiring two-handed operation for operator protection
- Press and hold to lower bowl partially or double tap to fully lower automatically

Bowl Options



VBOWL-100
100 qt. SST bowl



VBOWL-100BRKT
100 qt. SST bracketed bowl
compatible with MaxiLift



VLIFT-M100H
100 qt. bowl lift



VBTRUCK-100-ERGO
100 qt. bowl truck

Accessory Options



VBEBAT-100A-ERGO
100 qt. aluminum beater



VBEBAT-100SS-ERGO
100 qt. SST beater



VWHIP-100-ERGO
100 qt. SST whip



VHDWHIP-100-ERGO
100 qt. reinforced whip



VWINGWHIP-100-ERGO
100 qt. SST wing whip



VHOOK-100-ERGO
100 qt. SST hook



VSCRIP-100
100 qt. scraper kit



VCHUTE
SST ingredient chute



VPGUARD-100-ERGO
100 qt. SST partially shielded
bowl guard set



VFGUARD-100-ERGO
100 qt. SST fully shielded
bowl guard set



VTOOLRACK60-150
60-150 qt. tool rack

Reduction Accessories



VBOWL60-100
 VBOWL40-100
60 & 40 qt. SST bowl



VBEBAT60-100-ERGO
 VBEBAT40-100-ERGO
60 & 40 qt. aluminum



VHOOK60-100-ERGO
 VHOOK40-100-ERGO
60 & 40 qt. SST hook



VWHIP60-100-ERGO
 VWHIP40-100-ERGO
60 & 40 qt. SST whip



VWINGWHIP60-100-ERGO
 VWINGWHIP40-100-ERGO
60 & 40 qt. SST wing whip



VHDWHIP60-100-ERGO
 VHDWHIP40-100-ERGO
60 & 40 qt. reinforced whip



VSCRIP60-100
 VSCRIP40-100
60 & 40 qt. SST scraper kit



VBTRUCK60-100
 VBTRUCK40-100
60 & 40 qt. bowl truck

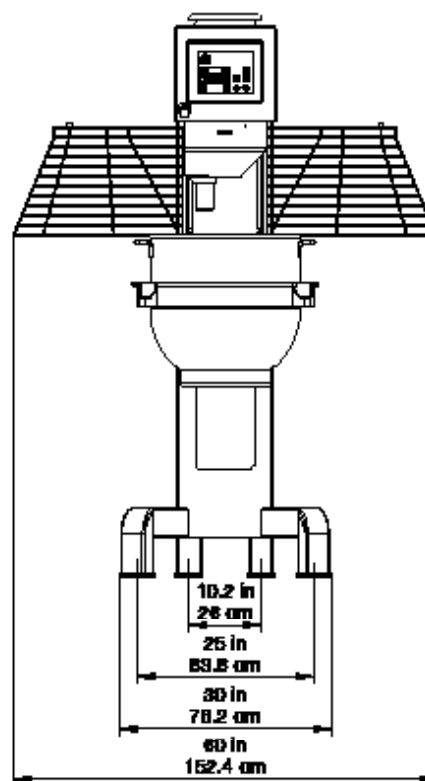
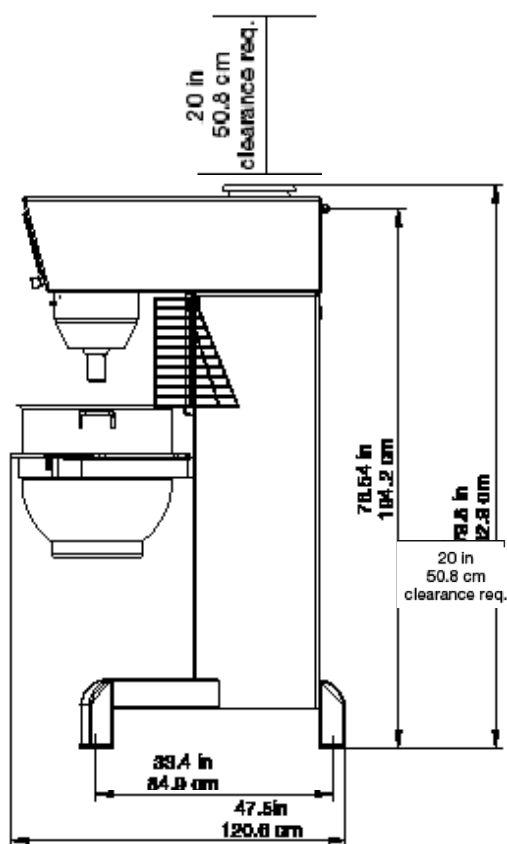

20

30r.

Consider door clearances for installation.

SPECIFICATIONS

Item Number	IP Rating	Motor	Volts	Amp	Mixing Speeds	Stir	Fixed Speeds			
							1	2	3	4
ERGO100-2	IP53	5 HP	208-240/60/3	16.5	46 - 259 RPMS	20	1	2	3	4
ERGO100-2IP54	IP54						46	137	198	259

DIMENSIONS | SHIPPING INFORMATION

Mixer ships with ingredient chute and bowl truck only. Liftgate is NOT recommended.

Item Number	Overall Dimensions	Net Wt.	Shipping Dimensions	Ship Wt.	Freight Class
ERGO100-2 ERGO100-2IP54	30" W x 47.5" D x 79.8" H (76.2 cm x 120.7 cm x 202.7 cm)	992.08 lbs. (450 kg)	33.46" W x 51.97" D x 89.37" H (84.99 cm x 132 cm x 227 cm)	1,091.29 lbs. (495 kg)	100

Stainless steel, ergonomic, heavy-duty 5 HP 100 quart mixer. Large touch screen display with programmable features and 90-minute digital timer. Programmable for up to 24 recipes. Agitator speed range from 46 to 259 RPMs. 6 foot power cord. Ability to remove the bowl without removing agitators. Mixer is IP53 standard, with IP54 upgrade option. ETL and NSF certified. Four-year parts and