

"OSC2F" OVERSHELVES - CANTILEVERED

Double Shelf, 16GA w/Flat Top

FEATURES:

- Stainless Steel Shelf With Stallion Safety Edge On Front & Rear
- 16GA, Type 300 Stainless Steel With #4 Polish, Satin Finish
- Uprights Are 1-1/2" Square 14GA Tubing, Type 300 Stainless Steel With #4 Polish, Satin Finish
- Single Overshelves Are Mounted 18" Above Table Top
- Double Overshelves Are Mounted 12" Above First Shelf
- Overshelves Feature Knockdown Setup

SPECIFICATIONS:

- Stainless Steel Overshelves Are TIG Welded
- Exposed Welds Are Polished To Match Adjacent Surfaces
- Shelf: 16GA, Type 300 Stainless Steel, #4 Polish, Satin Finish
- Uprights: 1-1/2" Square 14GA Tubing, 14GA Type 300 Tubular Stainless Steel #4 Polish, Satin Finish
- Heat Lamp Provision: OSEHLP-6XX 6=Width Of Provision, XX=Nominal Length Of Shelf

CERTIFICATIONS:



OSC26FK-1236

"OSC2F" CANTILEVERED OVERSHELVES

LENGTH (L)	12" WIDTH	WT. (LBS)	18" WIDTH	WT. (LBS)
36"	OSC26FK-1236	48	OSC26FK-1836	45
48"	OSC26FK-1248	52	OSC26FK-1848	50
60"	OSC26FK-1260	56	OSC26FK-1860	55
72"	OSC26FK-1272	60	OSC26FK-1872	60
84"	OSC26FK-1284	70	OSC26FK-1884	70
96"	OSC26FK-1296	75	OSC26FK-1896	80
108"	OSC26FK-12108	80	OSC26FK-18108	85
120"	OSC26FK-12120	85	OSC26FK-18120	90
132"	OSC26FK-12132	92	OSC26FK-18132	95
144"	OSC26FK-12144	98	OSC26FK-18144	100

ALL DIMENSIONS ARE TYPICAL. TOLERANCE +/- .500". JOHN BOOS & CO. RESERVES THE RIGHT TO CHANGE SPECIFICATIONS WITHOUT NOTICE.

DETAILED SPECIFICATIONS

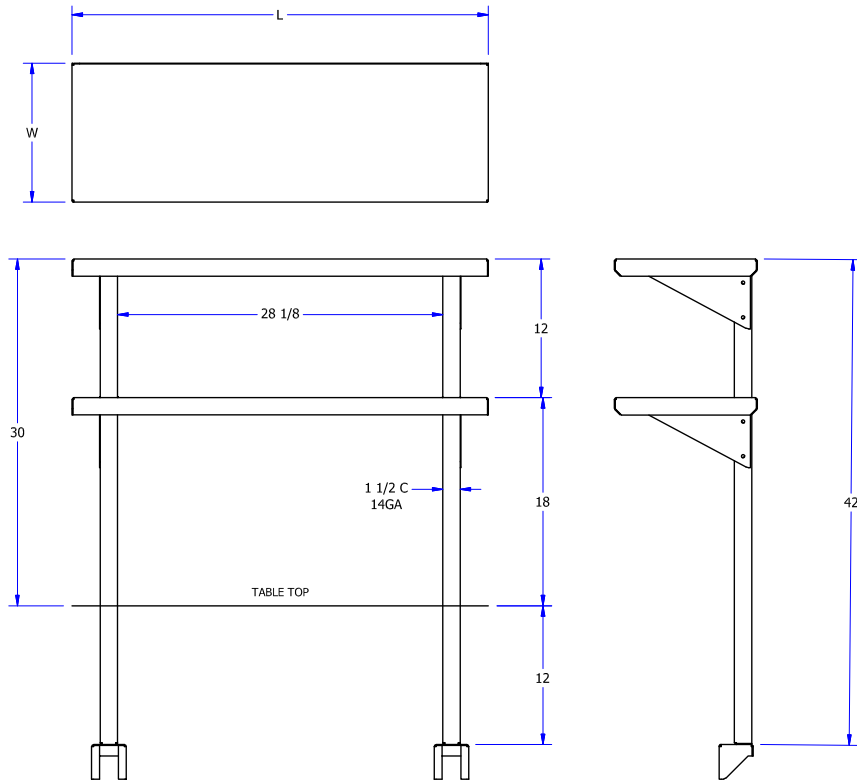

MODEL # STRUCTURE

6 = GA
 2 = # OF SHELVES
 C = Cantilevered
 OS = OVERSHELF

F = Flat TOP
 K = KNOCKDOWN
 12 = WIDTH (FRONT/BACK)
 36 = LENGTH (LEFT/RIGHT)

OSC26FK-1236

"OSC2F" CANTILEVERED OVERSHELVES

LENGTH (L)	12" WIDTH	WT. (LBS)	18" WIDTH	WT. (LBS)
36"	OSC26FK-1236	48	OSC26FK-1836	45
48"	OSC26FK-1248	52	OSC26FK-1848	50
60"	OSC26FK-1260	56	OSC26FK-1860	55
72"	OSC26FK-1272	60	OSC26FK-1872	60
84"	OSC26FK-1284	70	OSC26FK-1884	70
96"	OSC26FK-1296	75	OSC26FK-1896	80
108"	OSC26FK-12108	80	OSC26FK-18108	85
120"	OSC26FK-12120	85	OSC26FK-18120	90
132"	OSC26FK-12132	92	OSC26FK-18132	95
144"	OSC26FK-12144	98	OSC26FK-18144	100

ALL DIMENSIONS ARE TYPICAL. TOLERANCE +/- .500". JOHN BOOS & CO. RESERVES THE RIGHT TO CHANGE SPECIFICATIONS WITHOUT NOTICE.