

SHALLOW DEPTH BASE MODEL FREEZER

Model: FA68SNBS

Natural Refrigerant R-290 Model

68" Shallow Depth Base Model Freezer with Solid Doors & 5.5" Backsplash

Heavy gauge #300 Series stainless steel top, stainless steel front and end panels, galvanized steel rear and grill and aluminum interior.



Options and Accessories

(upcharge and lead times may apply)

Stainless steel interior	Condensing unit left (standard on right)
Stainless steel back	Door & Drawer Locks
Overshelves (single or double)	Front Breathing
Stainless steel shelves	Adjustable legs
Additional epoxy coated steel shelves	Drawers in lieu of doors**
Drawer in lieu of door section above the condensing unit*	

Consult factory for other model configurations, options and accessories.

*Drawer section above condensing unit holds (4) 1/6 pans

**Two tier (larger section): (1) 12 x 20 x 6 pan per drawer

Continental
Refrigerator



Project Name:

Model Specified:

Location:

Item No:

Quantity:

AIA #:

SIS #:

Standard Model Features

REFRIGERATION SYSTEM

Performance rated refrigeration system

Environmentally safe R-290 refrigerant

Unique forced air design utilizes fans (approx. every 12") across the entire back of unit for even distribution of cold

Automatic, energy saving, non-electric condensate evaporator

Non-corrosive, plasticized fin evaporator coil

Expansion valve system

Easily serviceable, slide out condensing unit

CABINET ARCHITECTURE

2" non-CFC polyurethane foam insulation

Spring loaded, self closing doors

Magnetic snap in Santoprene™ door gaskets

Heavy duty, epoxy coated steel shelves

Smooth, polished chrome door handles

Completely enclosed, vented and removable rear and side grills

5" Casters

MODEL FEATURES

Electronic control, off-cycle defrost

Reversing condenser fan motor (runs for short period during startup to clear any debris)

Refrigerated section with door above condensing unit

Field rehingeable doors

¹ R-290 refrigerant meets all federal and state regulatory requirements.

NOTE: Models come standard with a door over the condensing unit. A drawer over the condensing unit is an option.

APPROVAL:

Model Specifications

DIMENSIONAL DATA

Net Capacity (cubic feet)	17.6 (498 l)
Width, Overall (inches)	68 (1732 mm)
Depth, Overall (inches) (including handles & bumpers)	31 (770 mm)
Height, Overall (inches) (including 5" casters)	40.5 (1029 mm)
Shelf Area (square feet)	7.84 (0.7 sq m)
Number of Shelves	4
Number of Full Doors	2
Number of Half Doors	1
Interior Depth (inches)	24 (610 mm)
Interior Height (inches)	26 (660 mm)
Interior Height (inches) (above condenser)	12 1/2 (318 mm)

REFRIGERANT DATA

Condensing Unit Size (H.P.)	1/2
R-290 Refrigerant Charge (oz)	5.1
Capacity (BTU per hour)*	1980

ELECTRICAL DATA

Voltage (International)	115/60/1 (220/50/1)
Total Amps (International)	8.5 (4.3)
Defrost Amps (International)	9.1 (4.6)
10 ft. Cord/Plug [attached] (International)	Yes (No)

SHIPPING DATA

Weight (pounds)	390 (172 kg)
Height - Crated (inches)	45 (1194 mm)
Width - Crated (inches)	76 (1778 mm)
Depth - Crated (inches)	39 (1111 mm)

* Rating @ -15°F evaporator, 90°F ambient
 Figures in parentheses reflect metric equivalents rounded to the nearest whole unit.



Equipped with one NEMA-5-15P Plug
 (varies by country)

Model Plan Views

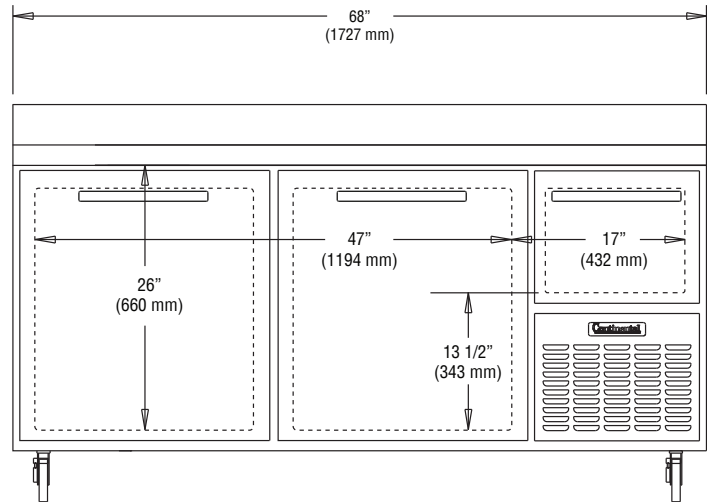

FRONT VIEW

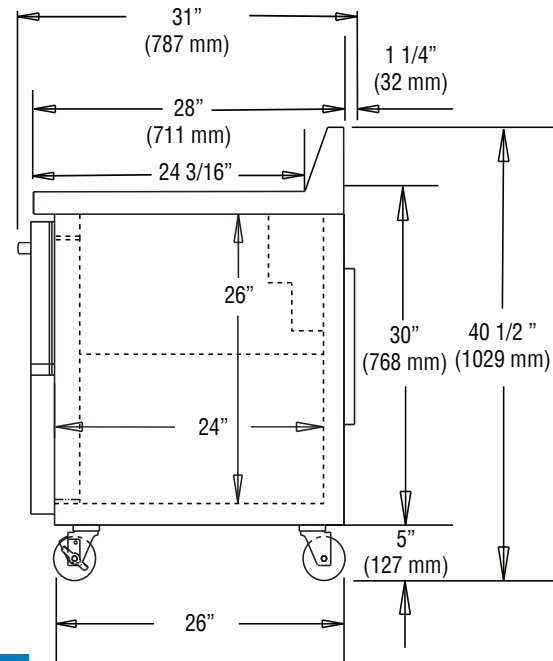

SIDE VIEW

Continental
 Refrigerator

Toll-Free: 800-523-7138
 Phone: 215-244-1400
 Fax: 215-244-9579

539 Dunksferry Road
 Bensalem, PA 19020
www.continentalrefrigerator.com

Due to our continued efforts in developing innovative products, specifications subject to change without notice.



PROUDLY
 DESIGNED & ASSEMBLED
 IN THE U.S.A.