



738230 (KCCF140WH)
Solid Top Chest Freezer 52" Long

Description

Solid top chest freezer, 52 inches long, with foamed lid and spring hinge closing mechanism to ensure gentle lid closure. Lid lock and key included. Internal and external structure in white painted steel for durable and sleek look. (1) coated wire storage basket, vertical basket divider, NSF thermometer included as standard. Defrost water drain with plug for easy cleaning.

Equipped with NEMA 5-15P plug.

R600a gas in the refrigeration circuit.
ETL Safety and Sanitation certifications.
1/5 Years warranty.

Main Features

- Foamed lid construction enhances thermal performance while reinforcing durability
- Removable gasket for easy cleaning operations.
- Bottom drain with plug for easy interior cleaning and defrost water discharge
- NSF®-Certified Temperature Gauge - Durable and reliable for safety in food storage
- Coated wire basket with vertical divider for convenient and organized storage (1 basket included)
- Mechanical temperature control panel ensures reliable operation and easy adjustment
- Internal temperature display providing clear visibility of operating conditions
- Removable rubber bumper guards for airflow spacing and shock absorption
- Cabinet capable of accepting 14 standard sized 3-gallon ice cream tubs

Construction

- Painted white steel exterior, for durable and sleek finish
- Internal drain for easy clean out.
- Durable white painted steel interior, ensuring easy cleaning and long-lasting performance
- Heavy-duty, locking casters keeps the unit in place but allow position adjusting.
- Even cooling throughout the unit with advanced cold wall technology
- Locking lids and key protect the contents of the unit.
- Spring-assisted hinge mechanism ensures smooth lid opening and controlled closing
- Foamed lid construction provides superior insulation and enhanced structural strength
- Static condenser design enhances efficiency while minimizing moving parts and service requirements

Sustainability

- CFC and HCFC free (ecological refrigerant type: R600a).
- High efficiency components to minimize the energy consumption still guaranteeing the highest performances.
- 70 mm insulation for energy saving

Optional Accessories

PNC Code	Description
Baskets	
882000	Basket for Solid Top Chest Freezer 22.63x8.15x7.52 in. (575x207x191 mm)

Technical specifications

Electric

Supply voltage:	115 V/1 ph/60 Hz
Electrical power max:	0.2 kW
Plug type:	USA NEMA 5-15P
Current consumption:	1.9 Amps
Compressor power:	1/5 hp
Power Cable Length:	3000 mm

Capacity:

Gross capacity:	14.3025 cu.feet
------------------------	-----------------

Key Information:

Number and type of grids (included):	1 ()
Door hinges:	1 Left+2 Right
External dimensions, Width:	51 3/4" (1314 mm)
External dimensions, Depth:	29 1/4" (743 mm)
External dimensions, height:	36 1/32" (915 mm)
Number and type of doors:	1 Full
Internal Dimensions (depth):	21 5/8" (550 mm)
Internal Dimensions (height):	26 1/2" (673 mm)
Internal Dimensions (width):	46 1/16" (1170 mm)
Net weight:	150 lbs (68 kg)
Shipping width:	30 1/2" (775 mm)
Shipping depth:	54 5/8" (1387 mm)
Shipping height:	41 9/16" (1055 mm)
Shipping weight:	187 lbs (85 kg)
Shipping volume:	40.04 ft ³ (1.13 m ³)
Type of external material:	White Prepainted Steel
Type of internal material:	White Prepainted Steel
Approvals	ENERGY STAR;ETL C&US;ETL SANITATION

Refrigeration Data

Operating temperature min.:	-20.2 °F (-29 °C)
Operating temperature max.:	10.4 °F (-12 °C)
Defrost type:	Manual
Evaporator type	Foamed
Refrigerant unit side:	Right

Sustainability

Refrigerant type:	R600a
GWP Index:	3
Refrigerant weight:	85 g

Front

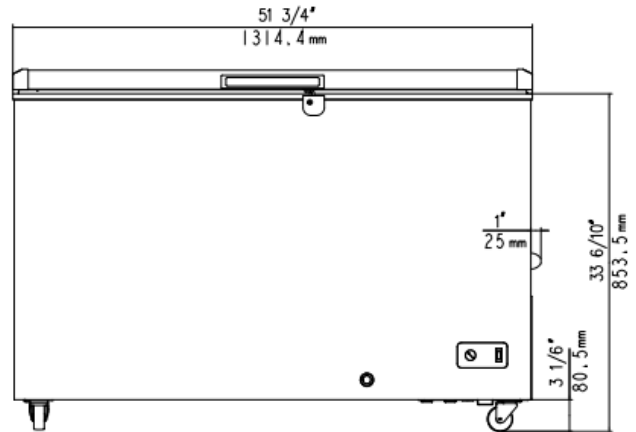

Side

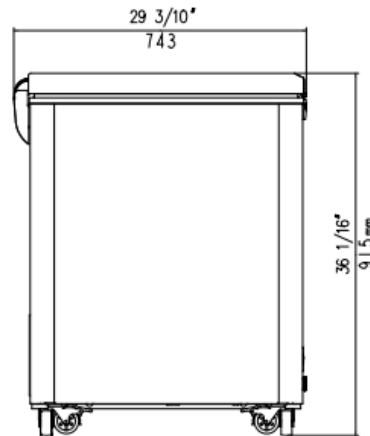

Top

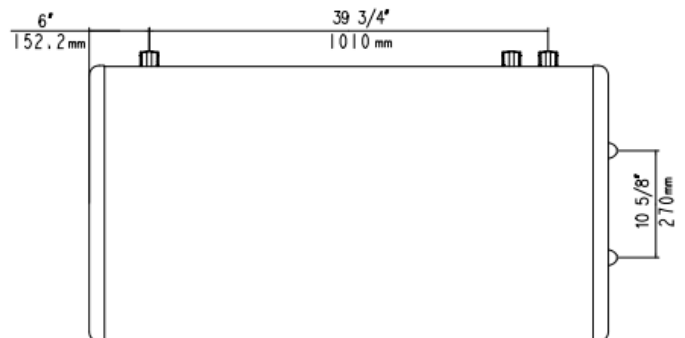

EI = Electrical inlet (power)

