

## Stainless Steel Utility Carts

### Handler Series, Standard Duty - 300 Lb. Capacity

Models 4311, 4322



### Easy Maneuvering In Tight Spaces For Back-Of-The-House Tasks

- Ergonomic vertical push handle
- Durable, unitized electronically welded angle leg frame
- 22-gauge stainless steel reinforced shelves
- Protective bumpers on legs protect furnishings
- Sound deadening panels under shelves reduce vibrations and noise
- 300 lb. (135 kg.) total load capacity
- Economical UPS/FedEx shipment

### Specifications:

Unit shall be of fully welded unitized construction with an overall carrying capacity of 300 pounds. Corner legs shall be of 16-gauge angle stainless steel. Shelves shall be of 22-gauge stainless steel with long shelf edges double hemmed for extra strength, and shall be electronically spot welded to upright legs at all points. Unit shall have a stainless steel one-piece vertical push handle (shipped unassembled), and shall have corner bumpers mounted to front legs. Unit shall have an independent galvanized steel dolly frame fastened to the bottom with 8 screws. Four each 3½" swivel casters shall be mounted to the dolly frame.

Spec. # \_\_\_\_\_

AIA # \_\_\_\_\_

Lakeside Manufacturing, Inc.

4900 West Electric Avenue • West Milwaukee, WI 53219 U.S.A.

800-558-8565 • 414-902-6400 • Fax 414-902-6446 • info@eLakeside.com • www.elakeside.com/foodservice

Models  
4311, 4322

# Stainless Steel Utility Carts

## Handler Series, Standard Duty - 300 Lb. Capacity

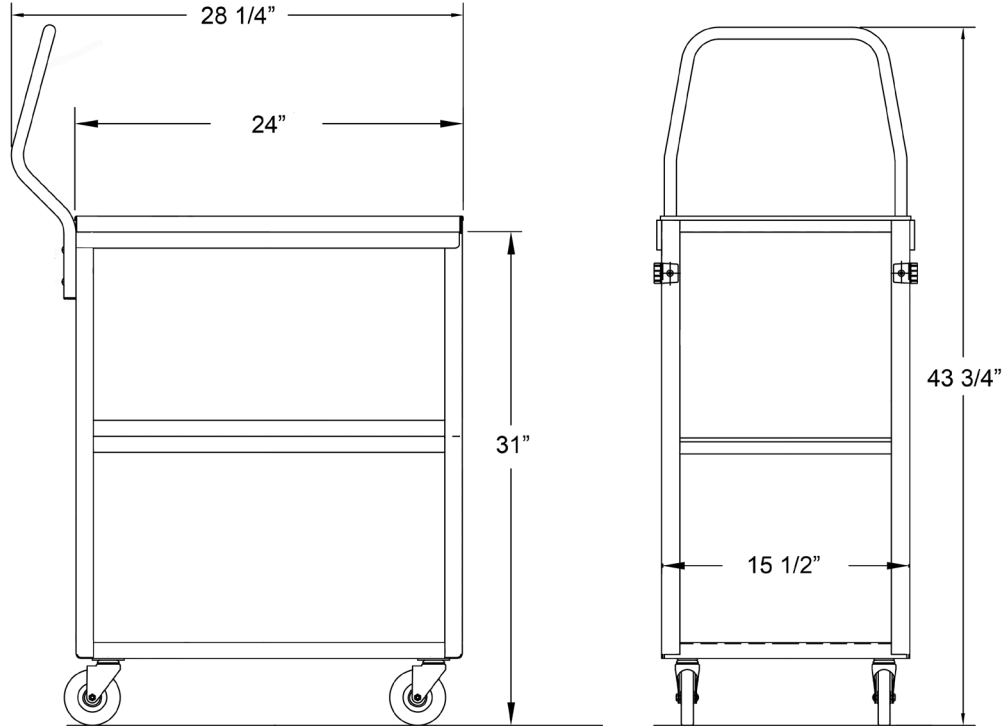

**Model 4311**

### Model Information

Model	Shelves		Top Shelf Height	Overall Size*			Case Weight		Case Cube	
	Size	Clearance (C)		W	L	H	Lbs.	(kg)	Cu. Ft.	(m <sup>3</sup> )
4311	15-1/2" x 24" (394 x 610)	11-3/4" (298)	31" (787)	16-1/4" (413)	28-1/4" (718)	43-3/4" (1113)	29	(13.2)	10.9	(.42)
4322	18" x 27" (457 x 686)	12-1/4" (311)	32" (813)	18-3/8" (467)	31-3/4" (807)	44-3/4" (1367)	32	(14.5)	16.3	(.63)

Measurements in ( ) denote metric millimeters, unless otherwise specified.  
\* With handle assembled.

### Optional Accessories

- Perimeter shelf mounted strip bumper
- Set of two ea. brake casters (4")



Lakeside Manufacturing, Inc.  
4900 West Electric Avenue • West Milwaukee, WI 53219 U.S.A.  
800-558-8565 • 414-902-6400 • Fax 414-902-6446  
info@eLakeside.com • www.elakeside.com/foodservice