



Evo, Inc.
 20360 SW Avery Ct.
 Tualatin, OR 97062
 P 503-626-1802 • F 503-213-5869
 www.evoamerica.com

Project: _____
 Location: _____
 Item #: _____ Qty: _____
 Model #: _____

AIA #

SIS#

10-0340-40E-CT

Model# 10-0340-40E-CT

Evo® Elevation™ 40E Cart

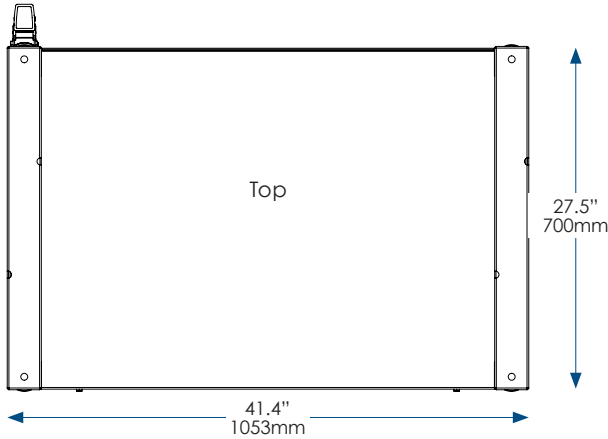

Elevation™ 40E w/
Cart Accessory

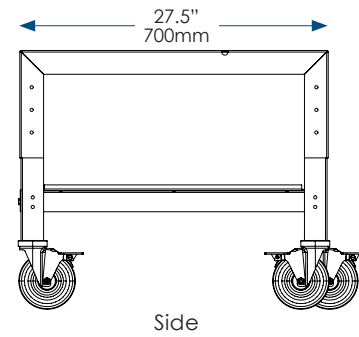
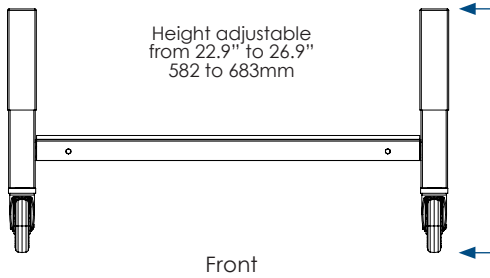

DIMENSIONS

MAXIMUM (W X D X H)
 41.4" x 27.5" x 26.9"
 (1053mm x 700mm x 683mm)

WEIGHT

NET: 90 lbs EST (41 kg)
 SHIP: 100 lbs EST (45 kg)

FEATURES

- Adjustable Height
- Full Size dry storage shelf
- Designed specifically for the Elevation 40E Plancha

CONSTRUCTION

- Bolt together construction
- 12 Ga. 304 Stainless Steel
- 2B Standard Finish
- Supports up to 650 lbs.

Due to ongoing product improvement, specifications are subject to change without notice.



UL/C-UL, Listing E514595 (United States and Canada)
 UL/C-UL EPH, Listing E470119 (United States and Canada)
 Investigations KNGT/KNGT7 (UL197)
 Investigations TSQT (NSF4)

