

Rear Up-Turn Work Tables

- Quality S/S unsurpassed strength and durability
- Top reinforced with welded-on hat channel
- Sound-deadened between top and channels
- Gussets are recessed into channel to reduce lateral movement
- 1-1/2" (WT-EBxxxx) & 4" (WT-PBxxxx) rear upturn with radius at intersection
- Rolled edge construction
- Adjustable ABS bullet feet
- Shipped knock-down

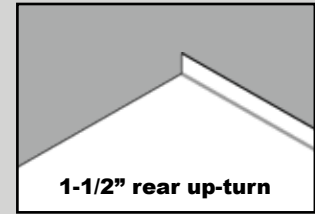

Optional Caster:
KS 6113



WT-EBxxxx:
18 Ga. 430 S/S Table Top
18 Ga. Galvanized Under shelf
18 Ga. Galvanized Legs

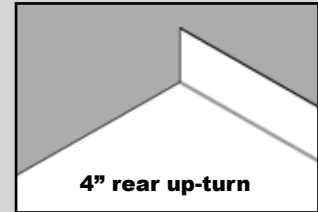

WT-PBxxxx:
16 Ga. 304 S/S Table Top
18 Ga. S/S Under shelf
18 Ga. S/S Legs

Work tables length 72" and above have 6 legs

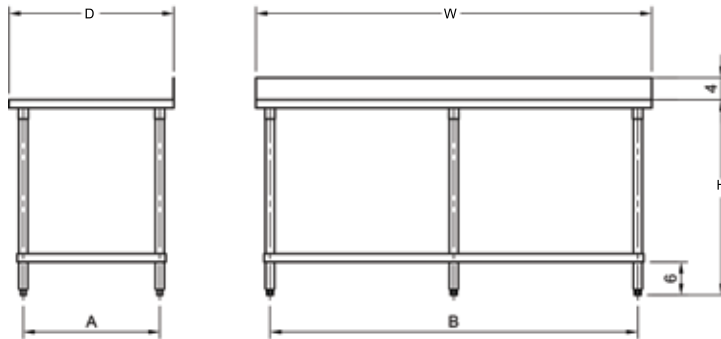

Item No.		D x W x H (in)	Load Cap. (lb)		A (in)	B (in)	Approx. Weight (lb)
1-1/2" Up-Turn	4" Up-Turn		Top Shelf	Under shelf			
WT-EB2424	WT-PB2424	24 x 24 x 35	260	150	18-1/8	17-1/8	39
WT-EB2430	WT-PB2430	24 x 30 x 35	320	190	18-1/8	23-1/8	45
WT-EB2436	WT-PB2436	24 x 36 x 35	350	200	18-1/8	29-1/8	51
WT-EB2448	WT-PB2448	24 x 48 x 35	400	240	18-1/8	41-1/8	62
WT-EB2460	WT-PB2460	24 x 60 x 35	450	270	18-1/8	53-1/8	79
WT-EB2472	WT-PB2472	24 x 72 x 35	420	250	18-1/8	65-1/8	99
WT-EB2484	WT-PB2484	24 x 84 x 35	420	250	18-1/8	77-1/8	111
WT-EB2496	WT-PB2496	24 x 96 x 35	400	240	18-1/8	89-1/8	125
WT-EB3012	WT-PB3012	30 x 12 x 35	195	120	24-1/8	5-1/8	31
WT-EB3018	WT-PB3018	30 x 18 x 35	230	130	24-1/8	11-1/8	38
WT-EB3024	WT-PB3024	30 x 24 x 35	390	230	24-1/8	17-1/8	39
WT-EB3030	WT-PB3030	30 x 30 x 35	460	270	24-1/8	23-1/8	50
WT-EB3036	WT-PB3036	30 x 36 x 35	420	250	24-1/8	29-1/8	57
WT-EB3048	WT-PB3048	30 x 48 x 35	480	280	24-1/8	41-1/8	73
WT-EB3060	WT-PB3060	30 x 60 x 35	540	320	24-1/8	53-1/8	88
WT-EB3072	WT-PB3072	30 x 72 x 35	500	300	24-1/8	65-1/8	109
WT-EB3084	WT-PB3084	30 x 84 x 35	500	300	24-1/8	77-1/8	126
WT-EB3096	WT-PB3096	30 x 96 x 35	480	280	24-1/8	89-1/8	141