

BASE MODEL REFRIGERATOR

Model: RA60N-D

Natural Refrigerant R-290 Model

60" Base Worktop Refrigerator with Drawers

Heavy gauge #300 Series stainless steel top, stainless steel front and end panels, galvanized steel rear and grill and aluminum interior.



Options and Accessories

(upcharge and lead times may apply)

| | |
|---|-------------------------------------|
| Stainless steel interior | Different size casters |
| Stainless steel back | Adjustable legs |
| Overshelves (single or double) | Door locks |
| Drawer in lieu of door section above the condensing unit* | Front breathing |
| | Compressor left (standard on right) |

Consult factory for other model configurations, options and accessories.

*Drawer section above condensing unit holds (1) 12 x 20 x 6 pan.

Continental
Refrigerator



Project Name:

Model Specified:

Location:

Item No:

Quantity:

AIA #:

SIS #:

Standard Model Features

REFRIGERATION SYSTEM

Performance rated refrigeration system

Natural, environmentally safe, high efficiency R-290 refrigerant¹

Unique forced air design utilizes fans (approx. every 12") across the entire back of unit for even distribution of cold

Automatic, hot gas condensate evaporator

Non-corrosive, plasticized fin evaporator coil

Easily serviceable, slide out condensing unit

Expansion valve system

CABINET ARCHITECTURE

2" non-CFC polyurethane foam insulation

Smooth, polished chrome door & drawer handles

Spring loaded, self closing door over condensing unit

Magnetic snap in Santoprene™ door & drawer gaskets

Stainless steel roll out drawers

Completely enclosed, vented and removable rear and side grills

5" casters

MODEL FEATURES

Electronic control, off cycle defrost

Reversing condenser fan motor (runs for short period during startup to clear any debris)

Refrigerated section with door above the condensing unit

Field rehingeable door over condensing unit

¹ R-290 refrigerant meets all federal and state regulatory requirements.

NOTE: Models come standard with a door over the condensing unit. A drawer over the condensing unit is an option.

APPROVAL:

Model Specifications

DIMENSIONAL DATA

| | |
|--|---------------|
| Net Capacity (cubic feet) | 19 (538 l) |
| Width, Overall (inches) | 60 (1524 mm) |
| Depth, Overall (inches) (including handles & bumpers) | 37 (939 mm) |
| Height, Overall (inches) (including 5" casters) | 35 (889 mm) |
| Number of Drawers | 4 |
| Number of Half Doors | 1 |
| Interior Depth (inches) (above condenser) | 30 (762 mm) |
| Interior Height (inches) (above condenser) | 12 ½ (318 mm) |
| Interior Width (inches) (smaller section) | 17 (432 mm) |

REFRIGERANT DATA

| | |
|-------------------------------|------|
| Condensing Unit Size (H.P.) | ¼ |
| R-290 Refrigerant Charge (oz) | 3.6 |
| Capacity (BTU per hour)* | 1930 |

ELECTRICAL DATA

| | |
|--|---------------------|
| Voltage (International) | 115/60/1 (220/50/1) |
| Total Amps (International) | 3.0 (1.5) |
| 10 ft. Cord/Plug [attached] (International) | Yes (No) |

SHIPPING DATA

| | |
|--------------------------|--------------|
| Weight (pounds) | 480 (218 kg) |
| Height - Crated (inches) | 45 (1111 mm) |
| Width - Crated (inches) | 69 (1575 mm) |
| Depth - Crated (inches) | 39 (1194 mm) |

DRAWER PAN CONFIGURATIONS

Two Tier: (2) 12 x 20 x 6 pans per drawer

Two Narrow: (1) 12 x 20 x 6 pan per drawer (supplied by others)

* Rating @ +25°F evaporator, 90°F ambient
Figures in parentheses reflect metric equivalents rounded to the nearest whole unit.



Equipped with one NEMA-5-15P Plug
(varies by country)

Model Plan Views

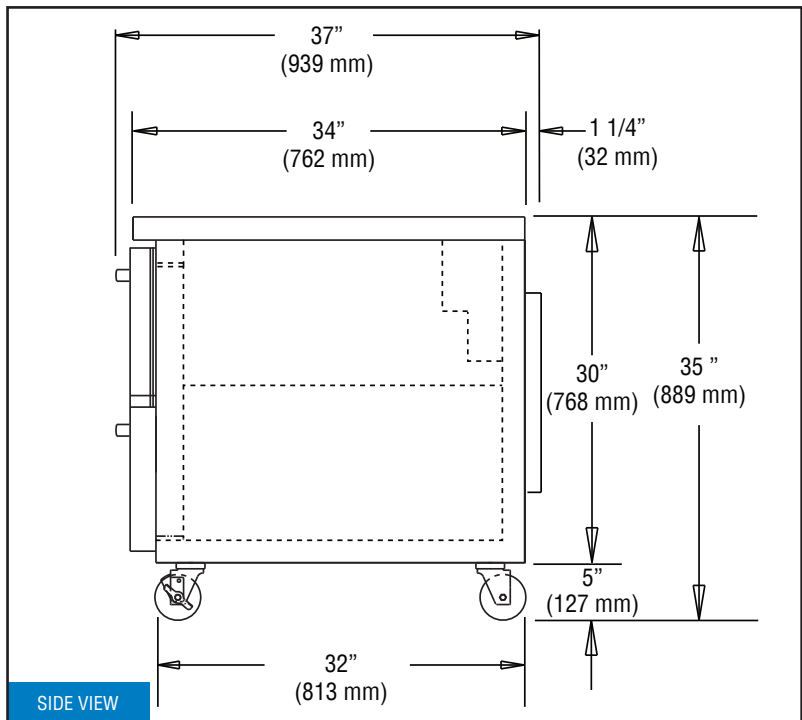
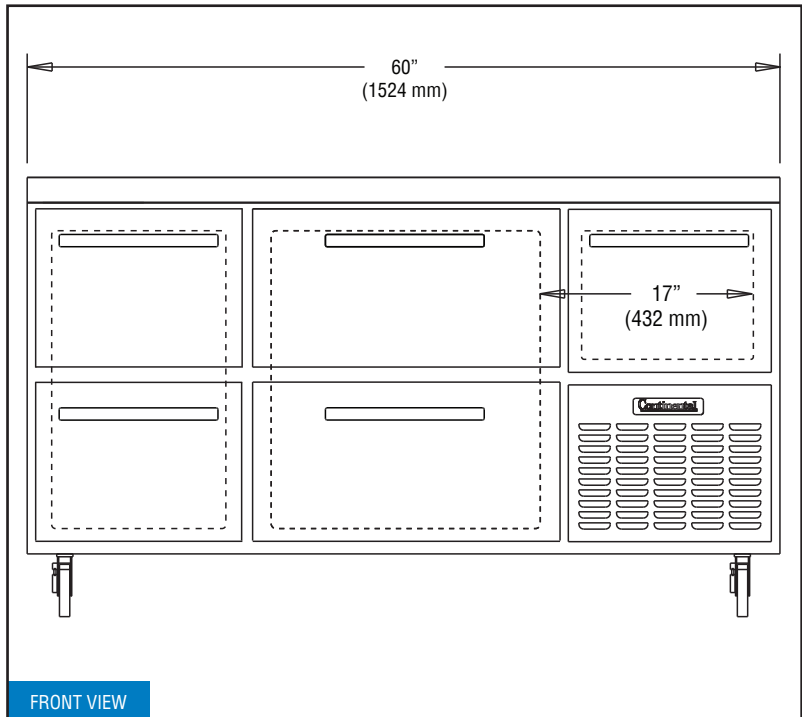

IMPORTANT NOTE: If the cabinet is located directly against a wall, a minimum clearance of 3" is required on sides, front and rear.

Continental
Refrigerator

Toll-Free: 800-523-7138
Phone: 215-244-1400
Fax: 215-244-9579

539 Dunksferry Road
Bensalem, PA 19020
www.continentalrefrigerator.com

Due to our continued efforts in developing innovative products, specifications subject to change without notice.



PROUDLY
DESIGNED & ASSEMBLED
IN THE U.S.A.

Intertek

© Copyright 2021. Continental Refrigerator.

REVISED: 4/30/26