



# BEVERAGE-AIR

Project: _____	AIA#
Item: _____	
Location: _____	SIS#
Approved: _____	

# WTRCS36HC CHEF BASE REFRIGERATOR

## CHEF BASE REFRIGERATOR

### WTRCS36HC Two Drawer Chef Base Hydrocarbon Series

**MODEL:**  
**WTRCS36HC**



**5 Year Parts/Labor Warranty Available**  
**7 Year Compressor Warranty**

#### CABINET CONSTRUCTION

- Stainless steel front, sides, drawers and grille (galvanized back & bottom)
- Interior liner is made of corrosion resistant aluminum
- Top has full marine edge to prevent spills from dripping over sides
- Full electronic control
- Top weight capacity 1000 lbs
- One-piece, snap-in magnetic drawer gasket
- 12-Gauge stainless steel drawer slides with Delrin® rollers rated at 275 lbs
- Lifetime warranty on all drawers and slides
- Heavy duty, fire-proof, reinforced insulated 16 gauge top
- No heat shield required (must adhere to proper clearance per owners manual)
- Accommodates 6" deep full size food service pans (not included)
- Self-closing drawer feature
- Compressor available on left or right, specify at time of unit order
- 3" Casters, 2 with brakes standard

#### OPTIONS & ACCESSORIES

- 3 Year parts/labor standard, additional 2 year warranty available
- Stainless steel back
- Stainless steel interior
- Additional pan supports
- 6" Adjustable legs, 6" seismic legs
- 6" Casters
- Gasket guards
- Flat top overhang  
(up to 6" overhang on each side)
- Remote option\*  
(refrigerant must be specified at time of order, see note on back on page)

#### REFRIGERATION SYSTEM

- Uses environmentally friendly, energy efficient R290 refrigerant, and meets all regulatory requirements for CARB, SNAP, DOE & more
- Adaptive defrost
- Non-electric defrost with hot gas condensate evaporation
- Refrigerator capable of maintaining product temperature 36°F to 38°F



  
Please verify qualifying units by visiting:  
[www.energystar.gov/cfs](http://www.energystar.gov/cfs)

3779 Champion Blvd., Winston-Salem, NC 27105  
1-888-845-9800 Fax: 1-336-245-6453  
[Beverage-Air.com](http://Beverage-Air.com) [Sales@bevair.com](mailto:Sales@bevair.com)



# BEVERAGE-AIR

MODEL	WTRCS36HC
<b>EXTERNAL DIMENSIONAL DATA</b>	
Width Overall	36"
Depth Overall (with handle & bumper)	34 3/4"
Height Overall (with casters)	24 3/8"
No. of Drawers	2
Depth with Drawers Extended	61 3/4"
Drawer Openings	(2) 22 1/2" x 6 1/2"
<b>INTERNAL DIMENSIONAL DATA</b>	
NET Capacity (cubic ft.)	5.64
Internal Width Overall (in)	22 7/8"
Internal Depth Overall (in)	26"
Internal Height Overall (in)	16 3/8"
<b>ELECTRICAL DATA</b>	
Full Load Amperes	1.7
<b>REFRIGERATION DATA</b>	
Horsepower	1/6
Capacity (BTU/Hr)	1110
Heat Rejection (BTU/Hr)	1665
Charge (lbs/grams/ounces)	0.265 / 120 / 4.24
<b>WEIGHT DATA</b>	
Gross Weight - Crated	350 lbs
Height - Crated	27"
Width - Crated	40"
Depth - Crated	38"

\*NOTE: Remote units are field wired and come with 6" legs. Refrigerant must be specified at time of order.

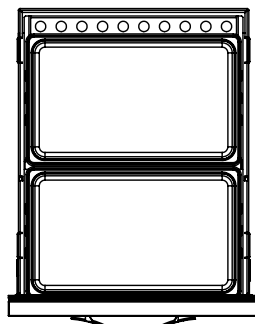

(Per drawer)

## Chef Base Refrigerator Model: WTRCS36HC

### Model Views

Required Clearance: Bottom 3 3/4" & Rear 1"

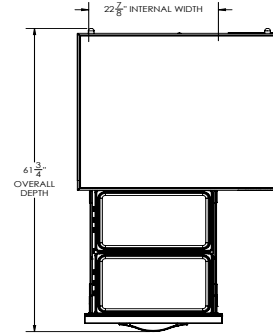

### PLAN VIEW

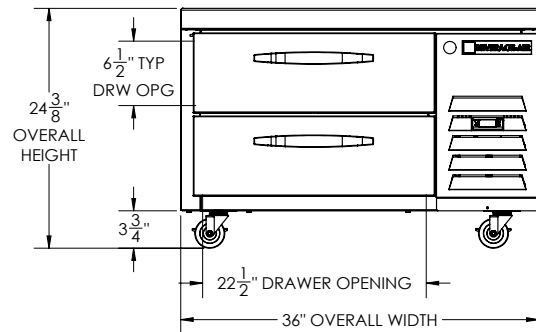

### ELEVATION VIEW

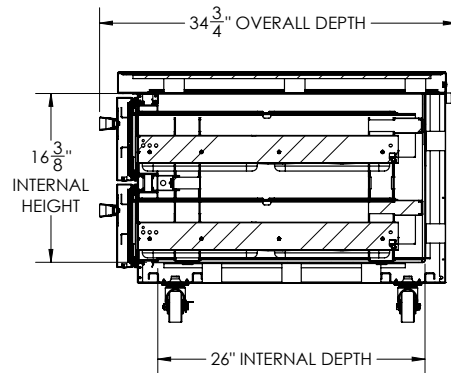

### SIDE VIEW

### ELECTRICAL CONNECTION



115/60/1  
NEMA 5-15P

Unit pre-wired at factory and include 8' long cord and plug set.

