



TRUE MANUFACTURING CO., INC.
U.S.A. FOODSERVICE DIVISION

2001 East Terra Lane • O'Fallon, Missouri 63366-4434 • (636)240-2400
Fax (636)272-2408 • Toll Free (800)325-6152 • Intl Fax# (001)636-272-7546
Parts Dept. (800)424-TRUE • Parts Dept. Fax# (636)272-9471 • www.truemfg.com

Project Name: _____

Location: _____

Item #: _____ Qty: _____

Model #: _____

A/A #

SIS #

Model:
TWT-48D-4-HC

Worktop:
Drawered Refrigerator with Hydrocarbon Refrigerant



TWT-48D-4-HC

- ▶ True's worktop units are designed with enduring quality that protects your long term investment.
- ▶ Designed using the highest quality materials and components to provide the user with colder product temperatures, lower utility costs, exceptional food safety and the best value in today's food service marketplace.
- ▶ Factory engineered, self-contained, capillary tube system using environmentally friendly R290 hydrocarbon refrigerant that has zero (0) ozone depletion potential (ODP), & 0.02 global warming potential (GWP).
- ▶ Oversized, environmentally friendly forced-air refrigeration system holds 33°F to 38°F (.5°C to 3.3°C).
- ▶ All stainless steel front, top and ends. Corrosion resistant GalFan coated steel back. Top and backsplash are one piece formed construction. Bacteria and food particles cannot be trapped underneath as with other two-piece worktop units.
- ▶ Interior - attractive, clear coated aluminum liner. Stainless steel floor with coved corners.
- ▶ Each drawer accommodates one (1) full size 12"L x 18"W x 6"D (305 mm x 458 mm x 153 mm) food pan (sold separately).
- ▶ Foamed-in-place using a high density, polyurethane insulation that has zero ozone depletion potential (ODP) and zero global warming potential (GWP).

ROUGH-IN DATA

Specifications subject to change without notice.
Chart dimensions rounded up to the nearest 1/8" (millimeters rounded up to next whole number).

Model	Drawers	Cabinet Dimensions (inches) (mm)			HP	Voltage	Amps	NEMA Config.	Cord Length (total ft.) (total m)	Crated Weight (lbs.) (kg)
		L	D†	H*						
TWT-48D-4-HC	4	48 3/8	30 1/8	33 3/8	1/5	115/60/1	2.0	5-15P	10	330
		1229	766	848	1/5	220-240/50-60/1	1.2	▲	3.05	150

† Depth does not include 1" (26 mm) for rear bumpers.

* Height does not include 6 1/4" (159 mm) for castors or 6" (153 mm) for optional legs.

▲ Plug type varies by country.



APPROVALS:

AVAILABLE AT:

Model:
TWT-48D-4-HC

Worktop:
Drawered Refrigerator with Hydrocarbon Refrigerant



STANDARD FEATURES

DESIGN

- True's commitment to using the highest quality materials and oversized refrigeration systems provides the user with colder product temperatures, lower utility costs, exceptional food safety and the best value in today's food service marketplace.

REFRIGERATION SYSTEM

- Factory engineered, self-contained, capillary tube system using environmentally friendly R290 hydrocarbon refrigerant that has zero (0) ozone depletion potential (ODP), & 0.02 global warming potential (GWP).
- Energy efficient, factory balanced refrigeration system with guided airflow to provide uniform product temperatures.
- High capacity, factory balanced refrigeration system that maintains cabinet temperatures of 33°F to 38°F (.5°C to 3.3°C) for the best in food preservation.
- State of the art, electronically commutated evaporator and condenser fan motors. ECM motors operate at higher peak efficiencies and move a more consistent volume of air which produces less heat, reduces energy consumption and provides greater motor reliability.
- Condensing unit access in back of cabinet, slides out for easy maintenance.

CABINET CONSTRUCTION

- All stainless steel front, top and ends. Corrosion resistant GalFan coated steel back. Top and backsplash are one piece formed construction. Bacteria and food particles cannot be trapped underneath as with other two-piece worktop units.

- Interior - attractive, clear coated aluminum liner. Stainless steel floor with coved corners.
- Insulation - entire cabinet structure and drawer facings are foamed-in-place using a high density, polyurethane insulation that has zero ozone depletion potential (ODP) and zero global warming potential (GWP).
- 5" (127 mm) diameter stem castors - locks provided on front set. 36" (915 mm) work surface height.

DRAWERS

- Stainless steel exterior drawer facings and liners. Stainless steel drawer frames.
- Each drawer fitted with 12" (305 mm) long recessed handle that is foamed-in-place with a sheet metal interlock to ensure permanent attachment.
- Magnetic drawer gaskets of one piece construction, removable without tools for ease of cleaning.
- Heavy-duty stainless steel drawer slides and rollers, removable without tools for easy cleaning.
- Each drawer accommodates one (1) full size 12"L x 18"W x 6"D (305 mm x 458 mm x 153 mm) food storage box (sold separately) or one ½ size and one ½ size pan.

MODEL FEATURES

- Evaporator is epoxy coated to eliminate the potential of corrosion.
- NSF/ANSI Standard 7 compliant for open food product.

ELECTRICAL

- Unit completely pre-wired at factory and ready for final connection to a 115/60/1 phase, 15 amp dedicated outlet. Cord and plug set included.



115/60/1
NEMA-5-15R

OPTIONAL FEATURES/ACCESSORIES

Upcharge and lead times may apply.

- 220-240V / 50-60 Hz.
- 6" (153 mm) standard legs.
- 6" (153 mm) seismic/flanged legs.
- 2 ½" (64 mm) diameter castors.
- Single overshelf.
- Double overshelf.
- 28 ¼" (718 mm) deep, ½" (13 mm) thick, white polyethylene cutting board. Requires "L" brackets.
- 28 ¼" (718 mm) deep, ½" (13 mm) thick, composite cutting board. Requires "L" brackets.
- Heavy duty, 16 gauge tops.
- Exterior rectangular digital temperature display (factory installed).
- ADA compliant models with 34" (864 mm) work surface height.

PLAN VIEW

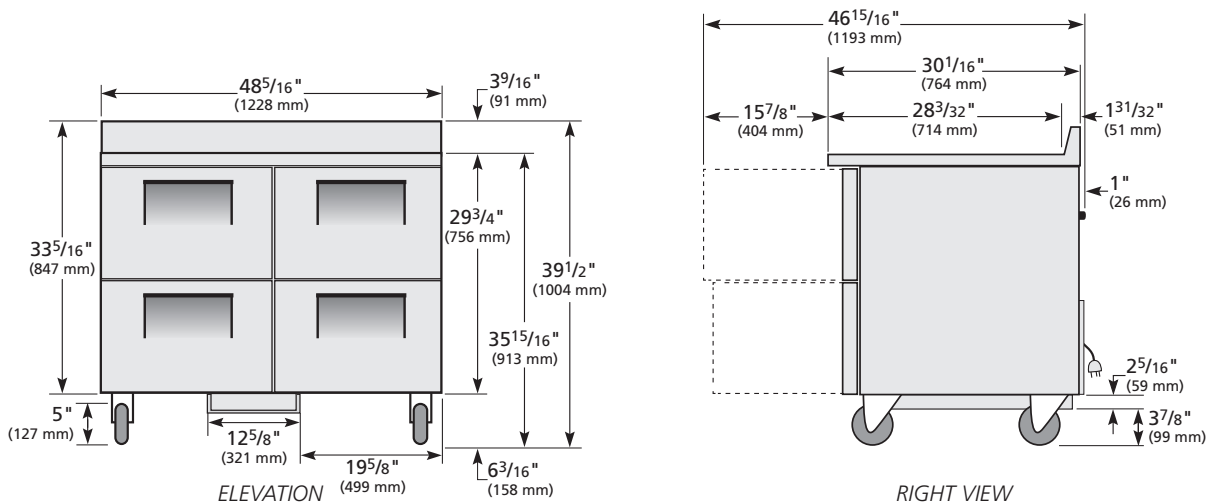

METRIC DIMENSIONS ROUNDED UP TO THE NEAREST WHOLE MILLIMETER

SPECIFICATIONS SUBJECT TO CHANGE WITHOUT NOTICE

	Model	Elevation	Right	Plan	3D	Back
	TWT-48D-4-HC	TFPY07E	TFPY06S	TFPY07P	TFPY073	

TRUE MANUFACTURING CO., INC.