

DEAN[®] SUPERRUNNER[®]

SR152 VALUE GAS FRYER



SR152

DEAN's Super Runner gas fryers are built for all-purpose use, handling everything from French fries to entrée items with oil capacities of 43, 50, or 75 lbs. The exclusive Thermo-Tube design ensures efficient heat transfer and oil preservation, while the wide cold zone traps debris to maintain oil quality. Simple, durable construction with fast recovery makes these fryers a dependable choice for high-volume kitchens.

Versatile, Affordable Frying: Easily fry everything from appetizers to chicken and breaded items—fresh or frozen—with a full-size frying area designed for all-purpose use.

Energy Efficiency that Translates to Savings: DEAN's Thermo-Tube design provides an additional 2" of tube height and 36% more heat transfer surface area. This reduces the heat per square inch on the oil by 22%, for more efficient heat transfer and longer lasting oil life.

Clean Oil, Better Taste: DEAN's wide cool zone traps debris below the cooking area to protect oil quality, while the sloped bottom allows fast, easy draining of oil and sediment.

Fast Recovery, Consistent Results: DEAN's responsive temperature probe quickly adjusts to load changes, minimizing wait time between batches and ensuring steady cooking performance.

Project _____
 Item _____
 Quantity _____ CSI Section 11400 _____
 Approval _____ Date _____

MODELS
 SR152

CONTROLLERS
 Millivolt (standard)

SPECIFICATIONS	
OIL CAPACITY	50-lbs. (25 liters) PER FRYPOT
FRYING AREA	14" × 14" × 3.5" (35 × 35 × 8.5 CM) PER FRYPOT
POT TYPE	Tube
GAS TYPE	Natural Gas Propane Mix
POWER	120,000 BTU/HR PER FRYPOT
STANDARD FEATURES	<ul style="list-style-type: none"> ▪ Thermo-Tube heat-transfer design ▪ Wide cold zone ▪ Durable temperature probe ▪ Combination gas valve with regulator ▪ No electric connection required ▪ Stainless steel frypot and door and aluminized sides
STANDARD ACCESSORIES	<ul style="list-style-type: none"> ▪ (2) Twin baskets PER FRYPOT ▪ Wire basket hanger ▪ Basket support rack ▪ 6"-7" (15-17 cm) adjustable steel legs

Liter conversions are for liquid shortening @ 70° F



REVISED SPRING 2026



318-865-1711
 1-800-221-4583
info@frymaster.com

8700 Line Avenue
 Shreveport, LA 71106-6800, USA
FRYMASTER.COM



DIMENSIONS	MODEL	OIL CAPACITY PER FRYPOT	OVERALL SIZE			DRAIN HEIGHT
			WIDTH	DEPTH	HEIGHT	
	SR152	50-lbs. (25 liters)	15.7" (39.8 cm)	31.1" (79.1 cm)	46.1" (117.1 cm)	17.5" (44.5 cm)

CRATED	MODEL	WEIGHT	WIDTH	DEPTH	HEIGHT	CU. FT.	CLASS
	SR152	180-lbs. (82 kg)	20.5" (52.1 cm)	36" (91.4 cm)	48.5" (123.2 cm)	22	85

Information is APPROXIMATE and may vary at time of shipment due to options/add-ons

GAS REQ.	GAS TYPE	INC. GAS PRESSURE	POWER
	NATURAL GAS	6" W.C.—14" W.C.	
LIQUID PROPANE	9" W.C.—14" W.C.		
MIXED GAS	11" W.C.—14" W.C.		

GAS CONNECTION	
FRYPOTS	SIZE NPT
1	(1) 3/4"

CLEARANCE INFORMATION

Front: 36" (91.4 cm) for servicing and proper operation.

Sides & Rear: 6" (15.2 cm) from any combustible material.

VENTILATION REQUIREMENTS

When installing any fryer, NFPA Standard No. 96 must be strictly followed.

NOTES

- **DO NOT CURB MOUNT**
- Split pots and basket lifts not available.

HOW TO SPECIFY

Electric or gas, gas type (if applicable), pot type, energy output, oil capacity, number of frypots, controller, filtration type, and optional feature(s).

- **Elevation:** Must specify elevation if between 2,000 – 6,000 ft. (Fryer may not perform at optimum levels above 6,000 ft.)

WARRANTY

Frypot

5 years: Pro-Rated

(No warranty for mobile kitchen applications)

All Other Parts

1 year: Parts + Labor

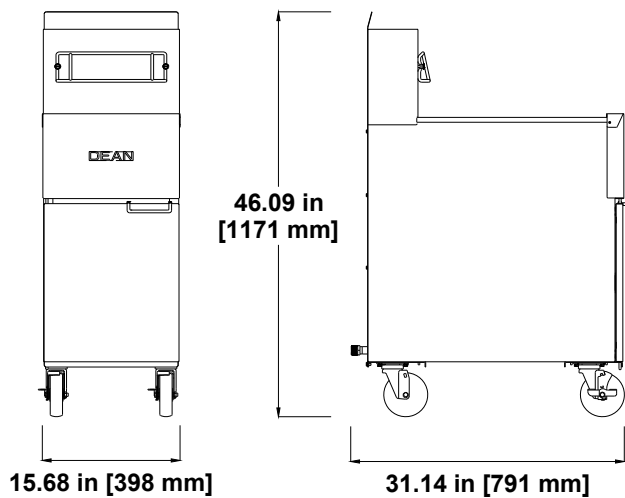

Frymaster reserves the right to make changes to the design or specifications without prior notice.

REVISED SPRING 2026