

# Champion<sup>®</sup>

The Dishwashing Machine Specialists

PROJECT: \_\_\_\_\_

ITEM # \_\_\_\_\_ QTY: \_\_\_\_\_

MODEL # \_\_\_\_\_

AIA # \_\_\_\_\_ SIS # \_\_\_\_\_

## 76 PRO-FF Electric

### HIGH TEMPERATURE ELECTRIC RACK CONVEYOR



Rendered image is for general visual representation only. Please refer to specifications for the latest detailed product information.

#### STANDARD FEATURES

- **54" Single Tank + 22" Prewash, Frontfeed**
- **Perpetual Rack Advance System**  
with digital jam monitoring, and mechanical drive protection
- **Automated Delime Function**  
with user-customizable alert intervals
- **255 Racks Per Hour**
- **.39 Gallons/Rack With Energy Sentinel** (idle pump shut-off)
- **Advanced Touchscreen Display**  
intuitive condition alerts, with user friendly cleaning and operation visual guidance, multi-lingual
- **Enhanced Visual On-board Diagnostics**  
quickly identify machine faults for rapid resolution and less downtime
- **Automatic Tank Fill**
- **Programmable Machine Dwell**  
pauses rack in wash zone for extended cleaning, NSF Certified Pot & Pan Mode
- **Automatic Drain Valve**
- **Single-Piece Hood Design**
- **Single-Piece Scrap Screen**  
more robust and faster cleaning
- **Single-Piece Stainless Steel Upper And Lower Wash Arm Manifolds**
- **Single-Point Electrical Connection**
- **20" Standard Vertical Clearance**  
accommodates 18" x 26" sheet pans
- **Fully Insulated Doors**  
open a full 180° for unrestricted cleaning access
- **All Stainless Steel Heavy Gauge Construction**  
including base, legs and feet
- **Enclosure Panels** (front and sides)
- **2 HP Pump Motor** with stainless steel impeller
- **Factory Authorized Start-Up**
- **Vent Fan Control**
- **ENERGY STAR® Certified**



#### SPECIFIER STATEMENT

Specified unit will be Champion model 76 PRO-FF Series high temperature rack conveyor front feeding dishwashing machine. Features top mounted prodigy HMI user interface controls with proactive maintenance software, proportional rinse, using only 100 GPH, optional built-in 21kW booster, progressive anti-jam drive system, energy sentinel (idle pump shut-off), 255 racks per hour, single-piece hood design, single-piece stainless steel upper & lower wash arms manifolds, full 180° opening leak proof insulated hinged access doors.

**1 Year parts and labor warranty.**

**In the USA:**  
3765 Champion Blvd, Winston-Salem, NC 27105  
Tel: (336) 661-1556 Fax: (336) 661-1979  
[www.championindustries.com](http://www.championindustries.com)

**In Canada:**  
2674 N. Service Rd., Jordan Station, Ontario, Canada L0R1S0  
Tel: (905) 562-4195 Fax: (905) 562-4618  
[www.championmoyerdiebel.ca](http://www.championmoyerdiebel.ca)

#### ACCESSORIES

- Drain water tempering kit (unmounted)
- Table limit switch, unmounted (recommended on all rack conveyor installations) (unmounted)
  - o WHISKER STYLE
  - o BUTTON STYLE
- Vent cowl, stainless steel with 7" stacks & locking dampers
- Extended vent cowl, with 7" stacks, locking dampers & external curtain (unload end only)
- Flanged feet (unmounted)
- Water hammer kit (unmounted)
- Chemical pump kit (detergent and rinse aid, mounted and interwired)
- Water pressure regulating valve (unmounted; standard with booster)
- Water softening system (manufactured, warrantied and serviced by Kinetico)
- Dish racks:
  - o PEG RACK
  - o FLAT RACK
- Splash shields (unload end only)
- Model PRO-90B unloader (90° corner conveyor table)
- Model RCT 64 or RCT 84 roller conveyor table (see factory for custom length)
- Stainless steel rear enclosure panels
- Correctional package (contact factory)

#### OPTIONS

- Two-point electrical connection, separate for machine and booster (field convertible)
- 33" Blower dryer – electric
- Booster heaters (completely interplumbed, controls are interwired)
  - o 40°F RISE (BUILT-IN) (FIELD CONVERTED)
  - o 70°F RISE (BUILT-IN)
- Direct link connectivity solution
- Direct link plus+ connectivity solution

**PRO-90B**  
90° Corner Conveyor  
table unloader  
available



**Model RCT 64 or RCT 84**  
Roller conveyor table



#### UTILITIES

<b>1</b>	<b>Electrical Connections</b> Machine electrical connection and booster electrical connection
<b>2</b>	<b>Hot Water</b> 25 PSI flowing pressure (machine with built-in booster) Main connection 1/2" NPT, 110° incoming water (Initial Fill = 25 Gal)
<b>4</b>	<b>Hot Water</b> 20 PSI flowing pressure (machine with no booster) Main water connection 1/2" NPT, 180° incoming water (Initial Fill = 25 Gal)
<b>5A</b>	<b>Drain</b> Connection 1-1/4" NPT Drain Max Flow Rate (g/min) 15
<b>8</b>	<b>Vents</b> A Stack connection – load end 150 CFM @ 1/4" static pressure B Stack connection – unload end 400 CFM @ 1/4" static pressure

**Warning:** Plumbing and electrical connections should be made by qualified personnel who will observe all the applicable plumbing, sanitary, and safety codes and the National Electrical Code.

**Note:** Water Hammer Arrestor (meeting ASSE-1010 standard or equivalent) to be supplied (by others) in common water supply line at service connection.

**Plumbing Notes:** Because of the variation in house-supplied steam and water pressures, steam and water pressure regulating valves (PRVs) may be needed. (Water PRV is standard on machines with booster.) The PRVs can either be purchased from Champion or obtained locally.

Champion does not endorse using on-demand (tankless) water heating systems, as well as PEX and other plumbing materials that may limit water flow, as these could impair machine performance. For optimal results, we recommend using appropriately sized conventional hot water tanks and standard copper water supply lines that adhere to our specifications. Not following these recommendations may void the manufacturer's warranty.

Water hardness of 3 grains/US Gal (0.83 Imp Gal) – 5.3 Mg/L or less

**Venting Notes:** Fabricated duct size: 3-7/8" x 15-7/8" (outside dimensions)

**Optional Drain Tempering:** 1/2" NPT cold water connection required. 1/2" NPT drain connection from back flow preventer to house drain. (FIELD INSTALLED and PLUMBED).

#### SPECIFICATIONS

Capacity	
Racks per hr (NSF rated)	255
Wash tank (US gal.)	17
Prewash tank (US gal.)	8
Conveyor speed (ft/min)	7.1
Conveyor speed Pot/Pan Mode (ft/min) (only one rack at a time in pot/pan)	5.4
Motor Horsepower	
Drive	1/6
Wash	2
Prewash	2
Water Consumption	
US Gal. per hr (max. use)	100
US Gal. per rack	.39
Heating	
Tank Heat, electric (kW)	15
Electric booster (built-in) (kW supplied for 40°F rise)	12
Electric booster (built-in) (kW supplied for 70°F rise)	21
Booster heaters completely inter plumbed, controls are interwired.	
Venting	
Load end (minimum CFM)	150
Unload end (minimum CFM)	400
Standard 20"x 20" Rack Complement	
Peg	1
Flat	1

## Single Tank PRO Rack Machine and Booster Ratings

The tables below give the ratings for each model. The ratings include the requirements of the 12 and 21 kW booster heaters when they are in use.

#### Machines with a single point electrical connection:

76 PRO-FF Electric Tank Heat, 21 kW 70° Booster			
Elec. Specs	Rated Amps	Minimum Supply Ckt. Conductor Ampacity	Maximum Overcurrent Protective Device
208/60/3	116	150	150
240/60/3	101	150	150
480/60/3	50	70	70
575/60/3	42	60	60

76 PRO-FF Electric Tank Heat, 12 kW 40° Booster			
Elec. Specs	Rated Amps	Minimum Supply Ckt. Conductor Ampacity	Maximum Overcurrent Protective Device
208/60/3	91	125	125
240/60/3	79	100	100
480/60/3	39	50	50
575/60/3	33	45	45

76 PRO-FF Electric Tank Heat, No Booster			
Elec. Specs	Rated Amps	Minimum Supply Ckt. Conductor Ampacity	Maximum Overcurrent Protective Device
208/60/3	58	80	80
240/60/3	50	70	70
480/60/3	25	35	35
575/60/3	21	30	30

#### Machines with a dual point electrical connection:

76 PRO-FF Electric, 21 kW Booster Only			
Elec. Specs	Rated Amps	Minimum Supply Ckt. Conductor Ampacity	Maximum Overcurrent Protective Device
208/60/3	59	80	80
240/60/3	51	70	70
480/60/3	26	35	35
575/60/3	22	30	30

76 PRO-FF Electric, 12 kW Booster Only			
Elec. Specs	Rated Amps	Minimum Supply Ckt. Conductor Ampacity	Maximum Overcurrent Protective Device
208/60/3	34	45	45
240/60/3	29	40	40
480/60/3	15	20	20
575/60/3	12	15	15

#### Note:

Machine ships as a single point electrical connection standard.

Easily converted to a dual point connection by a qualified electrician.

The machine ships standard with a 70°F booster when a booster is specified, but it is field convertible to a 40°F rise. See the installation packet or manual for conversion instructions.

# Champion®

The Dishwashing Machine Specialists

## 76 PRO-FF Electric

### HIGH TEMPERATURE ELECTRIC RACK CONVEYOR

Shipping weight crated: 1000 lbs. Dimensions shown in inches

Front View: Left to Right Model

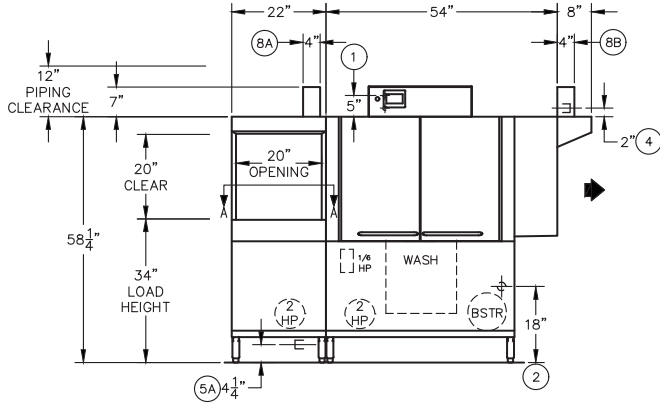

Front View: Right to Left Model

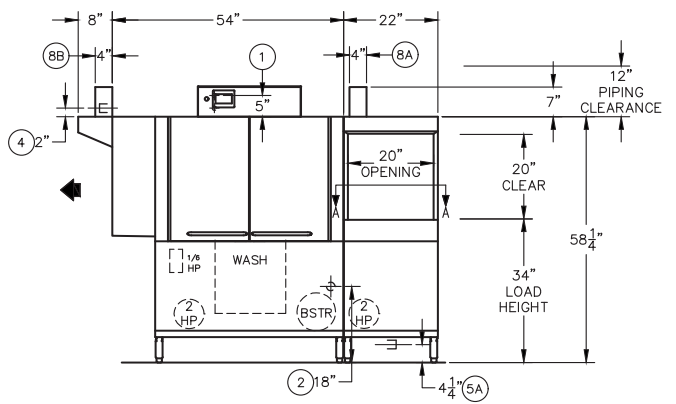

Plan View: Left to Right Model

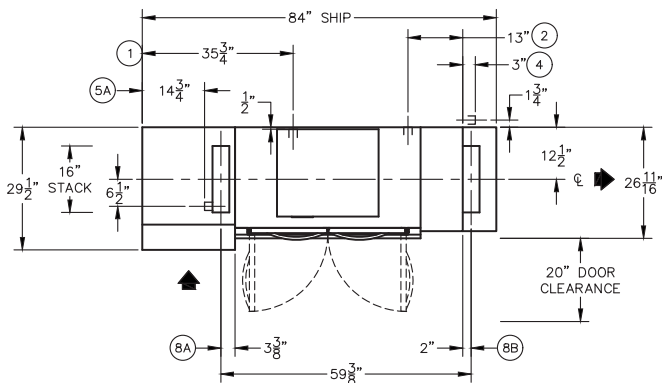

Plan View: Right to Left Model

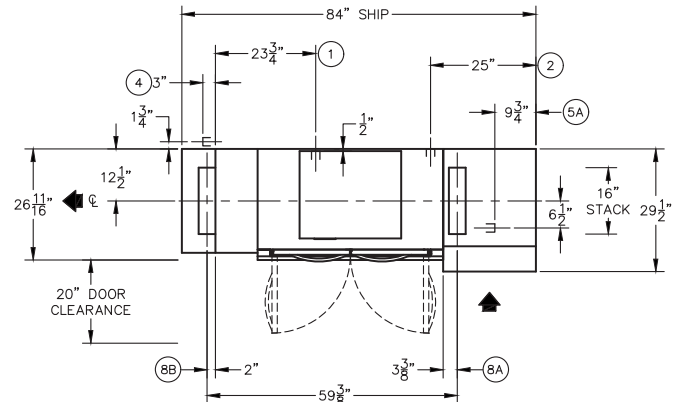

End View

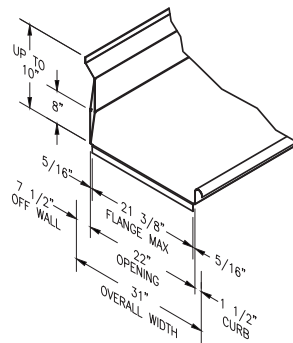
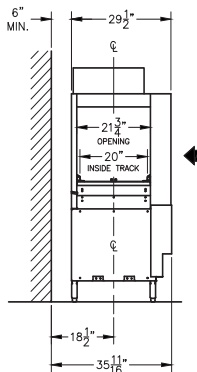

Suggested Table Construction

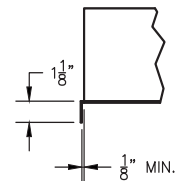

Flange Details

In the USA: 3765 Champion Blvd, Winston-Salem, NC 27105 | Tel: (336) 661-1556 Fax: (336) 661-1979 | [www.championindustries.com](http://www.championindustries.com)

In Canada: 2674 N. Service Rd., Jordan Station, Ontario, Canada LORISO | Tel: (905) 562-4195 Fax: (905) 562-4618 | [www.championmoyerdiebel.ca](http://www.championmoyerdiebel.ca)

Rev. 04/2026 Printed in U.S.A.

Due to an ongoing value analysis program at Champion, specifications contained in this catalog are subject to change without notice.