

ITEM #: _____	QTY: _____
MODEL #: _____	
PROJECT NAME: _____	

071320

3601 S. Banker St. Effingham, IL 62401 • P.O. BOX 609 • Ph: (888) 431-2667 • Fax: (800) 433-2667

"MHS-F" FLAT TOP MOBILE HAND WASH STATION

FEATURES:

- 16GA TYPE 300 FLAT STAINLESS STEEL TOP WITH #4 POLISH, SATIN FINISH
- 18GA STAINLESS STEEL PANELS
- 20GA STAINLESS STEEL HINGED DOOR WITH MAGNETIC CATCHES
- DROP-IN SINK (BOWL SIZE: 10"X14"X5")
- DECK MOUNT FAUCET 4" O.C. WITH GOOSENECK SPOUT
- SOAP AND PAPER TOWEL DISPENSER
- HEAVY DUTY 5" LOCKING CASTERS
- FRESH WATER PUMP
- 2.5 GALLON WATER HEATER
- 5 GALLON CLEAN WATER CONTAINER
- 6 GALLON GRAY WATER CONTAINER
- GFI OUTLET WITH 6' CORD
- ALL COMPONENTS ARE UL LISTED



CONSTRUCTION:

- TIG WELDED, EXPOSED WELDS ARE POLISHED TO MATCH ADJACENT SURFACE

MATERIAL:

- TOP: 16GA TYPE 300 STAINLESS STEEL WITH #4 POLISH, SATIN FINISH
- PANELS: 18GA STAINLESS STEEL
- SHELF: 18GA STAINLESS STEEL
- DOOR: 20GA STAINLESS STEEL

FLAT TOP MOBILE HAND WASH STATION

MODEL #	QTY
MHS-F-2624	

SOME UNITS SHIP UNASSEMBLED FOR REDUCED SHIPPING COST. ALL DIMENSIONS ARE TYPICAL. TOLERANCE +/- .500"

John Boos & Co. is constantly engaged in a program of improving products and therefore reserves the right to change specifications without prior notice.

DETAILED SPECIFICATIONS

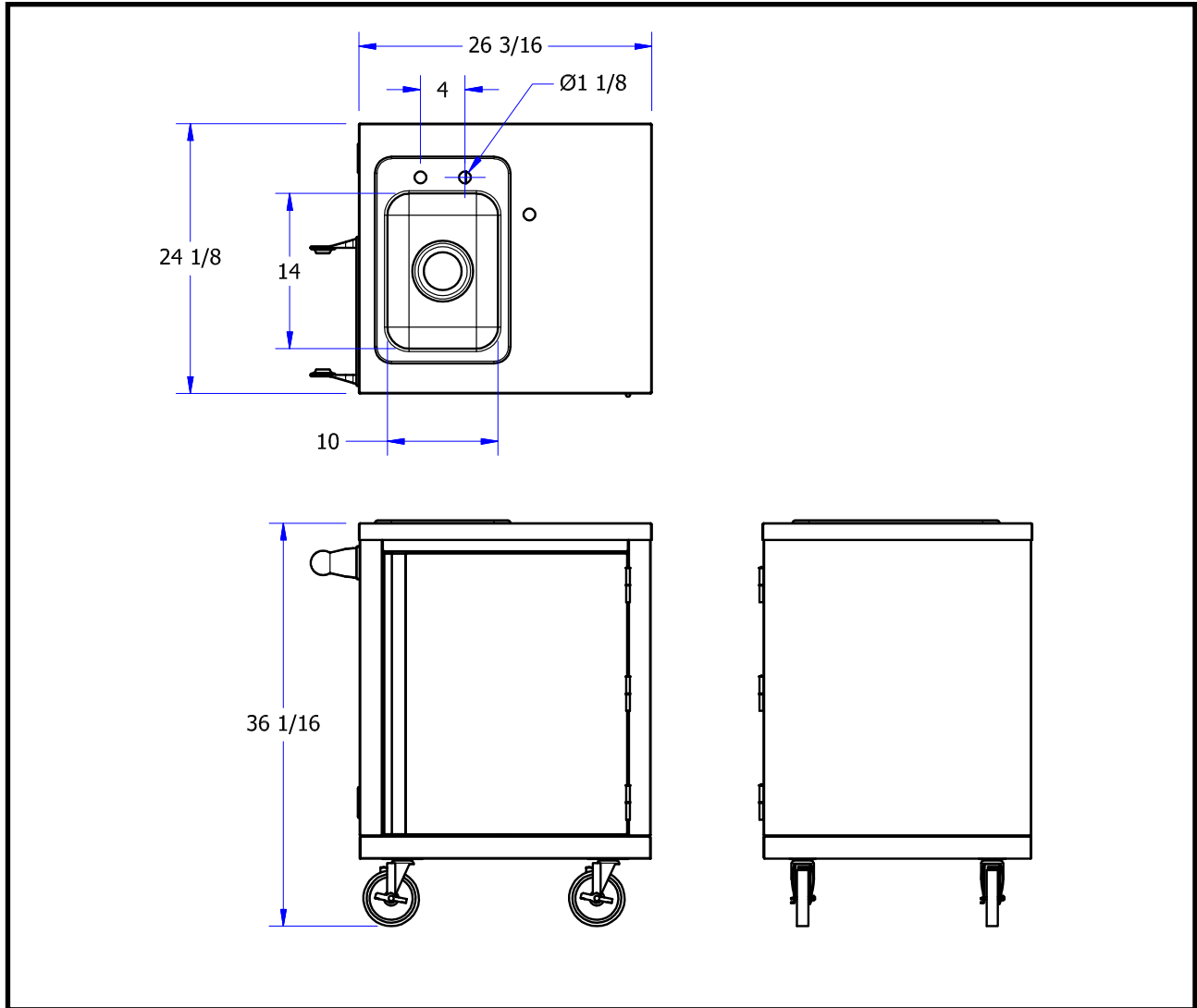

FLAT TOP MOBILE HAND WASH STATION

MODEL #	SIZE (W X D X H)	WEIGHT (LBS)
MHS-F-2624	26-3/16"X24-1/8"X36-1/16"	286

SOME UNITS SHIP UNASSEMBLED FOR REDUCED SHIPPING COST. ALL DIMENSIONS ARE TYPICAL. TOLERANCE +/- .500"
 John Boos & Co. is constantly engaged in a program of improving products and therefore reserves the right to change specifications without prior notice.

