



# BEVERAGE-AIR

|                 |      |
|-----------------|------|
| Project: _____  | AIA# |
| Item: _____     |      |
| Location: _____ | SIS# |
| Approved: _____ |      |

# DD24HC DIRECT DRAW DISPENSER

## DRAFT BEER EQUIPMENT-DIRECT DRAW DISPENSER

MODEL:  
DD24HC-1-B

DD24HC Solid Door Single Tower With Faucet  
Hydrocarbon Series



**7 Year Parts/Labor Warranty**  
**7 Year Compressor Warranty**

### CABINET CONSTRUCTION

- Exterior features durable black painted steel with galvanized steel back
- Top is made from heavy-duty stainless steel including drip tray
- Interior is galvanized steel on walls and ceiling, reinforced floor and doorsill are heavy-duty stainless steel
- Mechanical control
- Single tower with faucet
- 3-in-1 Draft solution uses a single stainless-steel tap to serve different beverages, such as wine, beer, and coffee (or other non-alcoholic beverages) through silver-lined, anti-microbial tubing that is 100% effective against the top 4 beverage spoiling bacteria
- 3" Stainless steel insulated dispensing tower
- Drain tube located at bottom front of cooler for connection to floor drain
- Four-inch (4") heavy duty casters standard
- Door lock
- Self-closing door with 120° stay-open feature
- Magnetic gaskets provide positive door seal
- Field reversible door (hinge kit not included)

### OPTIONS & ACCESSORIES

- Stainless steel interior lining
- Stainless steel back
- Wine/coffee models
- Glass door
- Faucet locks
- Glass rinser
- Right or left hinged door
- Sub-top
- No draft arm/hole cover
- 1- 4 Tap tower
- 2, 3 & 4 way manifolds
- Dial/digital thermometer

### REFRIGERATION SYSTEM

- Refrigeration system uses R290 refrigerant to comply with all environmental concerns
- Automatic, non-electric defrost
- Epoxy coated evaporator coil
- Maintains product temperatures between 36°F and 38°F



  
Please verify qualifying units by visiting:  
[www.energystar.gov/cfs](http://www.energystar.gov/cfs)

3779 Champion Blvd., Winston-Salem, NC 27105  
1-888-845-9800 Fax: 1-336-245-6453  
Beverage-Air.com Sales@bevair.com



# BEVERAGE-AIR

| MODEL                                | DD24HC-1-B         |
|--------------------------------------|--------------------|
| <b>EXTERNAL DIMENSIONAL DATA</b>     |                    |
| Width Overall                        | 24"                |
| Depth Overall                        | 30 1/8"            |
| Height Overall (floor to top of tap) | 53"                |
| Number of Doors                      | 1                  |
| Depth with Door Open 90°             | 50 3/4"            |
| Door Openings (in)                   | 19 3/4" x 28"      |
| <b>INTERNAL DIMENSIONAL DATA</b>     |                    |
| NET Capacity (cubic ft.)             | 7.66               |
| Internal Width Overall (in)          | 20"                |
| Internal Depth Overall (in)          | 22 1/4"            |
| Internal Height Overall (in)         | 23 1/2"            |
| Number of 1/2 Kegs                   | 1                  |
| <b>ELECTRICAL DATA</b>               |                    |
| Full Load Amperes                    | 2.0                |
| <b>REFRIGERATION DATA</b>            |                    |
| Horsepower                           | 1/6                |
| Capacity (BTU/Hr)                    | 1094               |
| Heat Rejection (BTU/Hr)              | 1641               |
| Charge (lbs/grams/ounces)            | 0.1213 / 55 / 1.94 |
| <b>SHIPPING DATA</b>                 |                    |
| Gross Weight - Crated                | 174 lbs            |
| Height - Crated                      | 46"                |
| Width - Crated                       | 32"                |
| Depth - Crated                       | 27"                |

\*NOTE: Remote units are field wired and come with 6" legs. Refrigerant must be specified at time of order.

We reserve the right to change specifications and product design without notice. Such revisions do not entitle the buyer to corresponding changes, improvements, additions or replacements for previously purchased equipment. Dimensional tolerances +/- 1/4". Metric dimensions (MM).

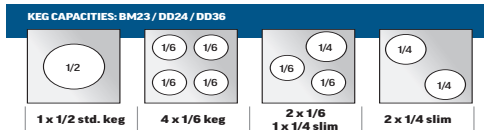

## Bar Equipment-Direct Draw Beer Dispenser Model: DD24HC-1-B

### Model Views

Required Clearance: 5 1/8" bottom

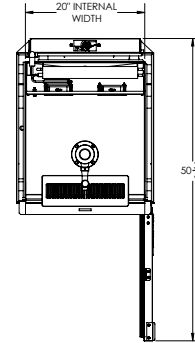

### PLAN VIEW

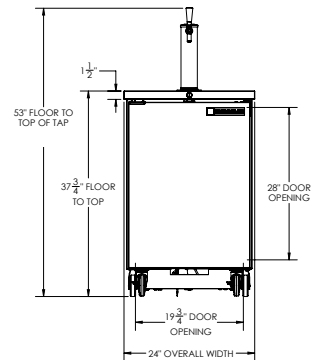

### ELEVATION VIEW

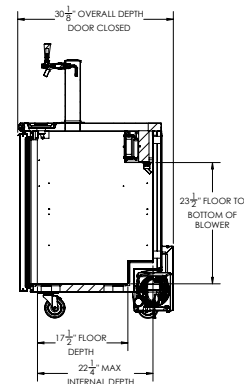

### SIDE VIEW

### ELECTRICAL CONNECTION



115/60/1  
NEMA 5-15P

Unit pre-wired at factory and include 8' long cord and plug set.

