



BEVERAGE-AIR®

PROJECT: _____
 ITEM # _____ QTY: _____
 MODEL # _____
 AIA # _____ SIS # _____
 APPROVED: _____

SALAD BAR

Model: SPE48HC-S

**7 YEAR WARRANTY
 Parts, Labor, and Compressor**

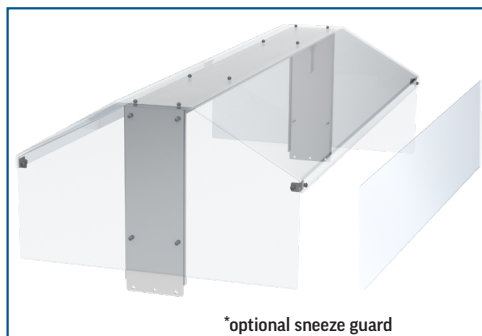

CABINET CONSTRUCTION

- Stainless steel front, sides, top, doors and grille (galvanized back & bottom)
- Interior liner is made of corrosion resistant aluminum
- Lift-off lid standard
- Heavy-duty aluminum pan liner, easy to clean and prevents spills from falling into cabinet while also ensuring coldest air flows across bottom of pans
- Six (6) 4" deep 1/3 size polycarbonate pans are included
- Accommodates up to 6" deep food service pans
- Locking divider bars
- Self-closing doors with 120° stay-open feature, on cartridge style hinges
- Easy door removal for service and cleaning
- Field-reversible doors with snap-in door gaskets
- 6" Casters, 2 with brakes
- Four (4) epoxy coated wire shelves



OPTIONS & ACCESSORIES

- Stainless steel exterior with finished back
- Stainless steel interior
- Dual-sided sneeze guard, with optional add on panel to convert to single side serving *
- Foldable tray slides
- Door locks
- 3" Casters, 6" legs, or low profile casters
- Shelf dividers
- Pan supports

REFRIGERATION SYSTEM

- Uses environmentally friendly, energy efficient R290 refrigerant, and meets all regulatory requirements for CARB, SNAP, DOE & more
- Adaptive defrost
- Epoxy coated evaporator coil
- Enhanced airflow maintains temperature between 36° to 38°F



BEVERAGE-AIR®

Salad Bar Model: SPE48HC-S

PLAN VIEW

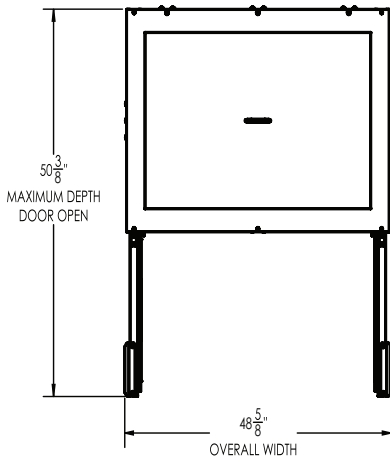

ELEVATION VIEW

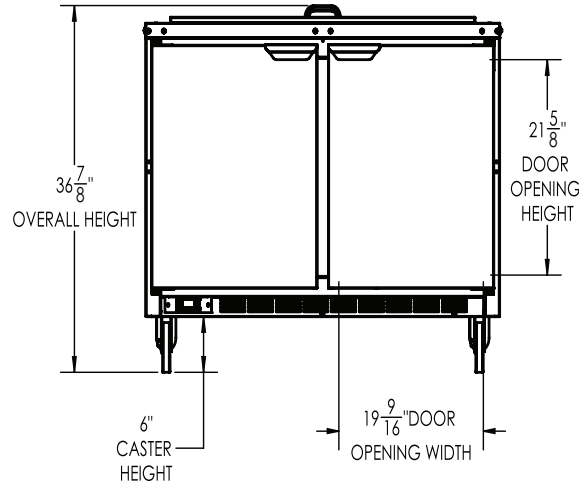

SIDE VIEW

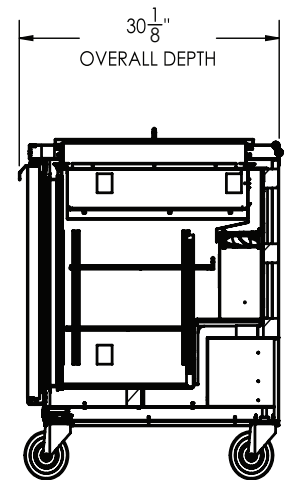

EXTERNAL DIMENSIONAL DATA	
Width Overall (in)	48 5/8"
Depth Overall (in)	30 1/8"
Height Overall (in)	36-7/8"
Number of Doors	2
Depth with Door open extended	50 3/8"
Door opening (in.)	19 9/16" x 21 5/8"
INTERNAL DIMENSIONAL DATA	
NET Capacity (cubic ft.)	13.01
Number of Shelves	4

*NOTE: Remote units are field wired and come with 6" legs.
Refrigerant must be specified at time of order.

We reserve the right to change specifications and product design without notice. Such revisions do not entitle the buyer to corresponding changes, improvements, additions or replacements for previously purchased equipment. Dimensional tolerances +/- 1/4". Metric dimensions (MM).

Required Clearance: 3" bottom & 2" rear

ELECTRICAL DATA	
Full Load Amps	2.2
Voltage	115/60/1
Nema Plug (8' cord)	5-15P
REFRIGERATION DATA	
Horsepower	1/6
Capacity (BTU/Hr)	1094
Heat Rejection (BTU/Hr)	1641
Charge (lbs/grams/ounces)	0.2425 / 110 / 3.9
SHIPPING DATA	
Gross Weight - Crated	334 lbs.
Height - Crated (in)	47"
Width - Crated (in)	50"
Depth - Crated (in)	33"

ELECTRICAL CONNECTION



115/60/1
NEMA 5-15P

Unit pre-wired at factory and include 8' long cord and plug set.

3779 Champion Blvd., Winston-Salem, NC 27105 | 888-845-9800 | Fax: 336-245-6453 | Beverage-Air.com | Sales@bevair.com

Date Issued 1/26 | Printed in U.S.A.