



HV-100G

HV-100G Full-Size Gas Hydrovection Oven



Shown on optional stand with casters and SmartTouch2 control

Project _____

Item No. _____

Quantity _____

Standard depth baking compartment - accepts five 18" x 26" standard full-size baking pans in left-to-right positions.

All data is shown per oven section, unless otherwise indicated.

Refer to operator manual specification chart for listed model names.

EXTERIOR CONSTRUCTION

- Fully welded angle-iron frame
- Stainless steel front, top, back and sides
- Simultaneous split door operation with catch-latch system
- Triple mounted door design with turnbuckle assembly
- Black glass doors with one piece curved handle
- Dual pane tempered viewing window features cool to the touch Low-E inner glass. Inner glass panel is hinged for easy cleaning
- Hand shower for ease of cleaning

INTERIOR CONSTRUCTION

- 304 stainless steel coved corner liner for easy cleaning
- Five stainless steel racks and ten rack positions
- Two halogen interior lights for superior visibility
- Drain in oven cavity
- Up to 2.5" of blanket insulation for greater heat retention

OPERATION

- Standard control with function selection for hot air, humidity and cool down plus ability to store 100 recipes
- Three inshot burners
- Direct spark ignition
- Incremental humidity control
- Hot air cook mode for baking and pastries
- Hydroburst feature for shot of 100% humidity at any time during the cook cycle
- Core probe cook and hold capabilities with 4" removeable fillet core temperature probe
- USB connection for recipe upload or download
- Four speed auto-reversing fan motor for even bake
- Cavity vent control provides ability to release steam at the push of a switch
- Thermostatically controlled quench system, Eco-Friendly

STANDARD FEATURES

- 25" (635mm) adjustable stainless steel legs (for single units)
- 8-1/2" (216mm) stainless steel legs with casters (for double sections)
- 1 year parts and 1 year labor warranty

* For all international markets, contact your local distributor.

OPTIONS AND ACCESSORIES

(AT ADDITIONAL CHARGE)

- **Legs/casters/stands:**
 - 6" casters for 25" legs
 - 11" (279mm) adjustable legs
 - 11" (279mm) seismic feet
 - 36" (914mm) stainless steel open stand with pan supports and feet
 - 36" (914mm) stainless steel open stand with pan supports and casters
- **Racks**
 - Extra stainless steel oven racks
 - Chicken roasting rack
 - Multi-purpose fry rack
- **Core Probes**
 - 4" duel sensing probe
 - 6" duel sensing probe
 - Additional 4" fillet probe
- SmartTouch2 control - NEW 7-inch touchscreen stores up to 500 recipes. Includes rack timing, multi-shelf recipes, easy download for recipe writing on your laptop, and HACCP storage capability
- Water pressure regulator
- Side heat shield
- Backflow preventer



Intertek



BLODGETT OVEN COMPANY

www.blodgett.com • 42 Allen Martin Drive, Essex Junction, VT 05452

Phone: (802) 658-6600 • Fax: (802) 864-0183



HV-100G



APPROVAL/STAMP

- ⊕ Gas ⊕ Gas Vent
- ⊕ Electric ⊕ Cavity Vent
- ⊕ Water ⊕ Drain

DIMENSIONS ARE IN INCHES [MM]

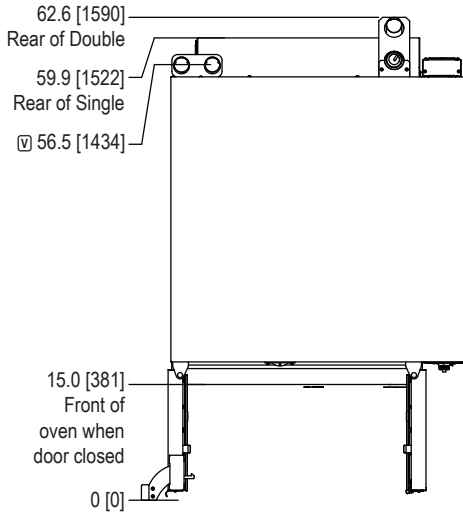

TOP VIEW
Double or Single Oven

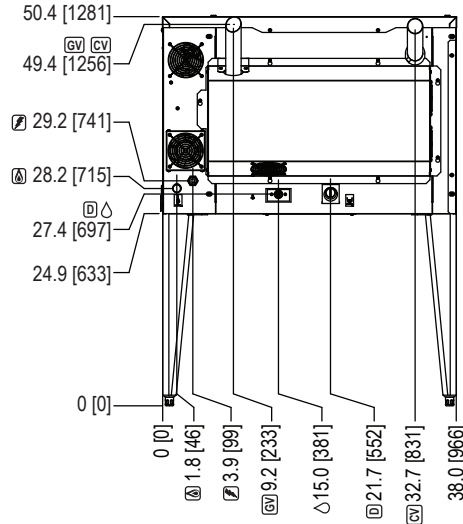

REAR VIEW Single Oven

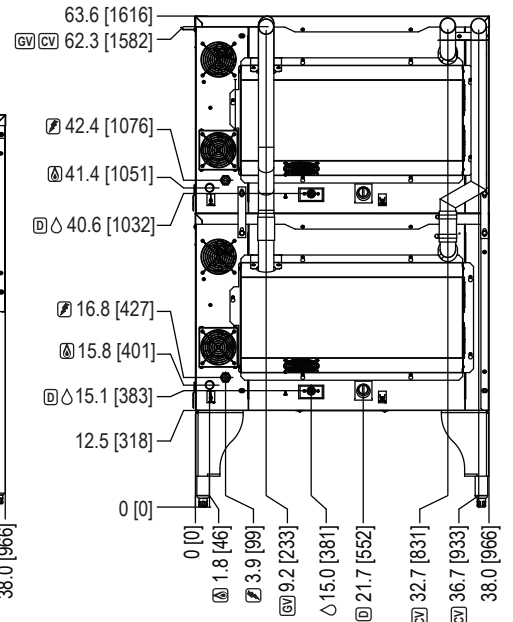

REAR VIEW Double Oven

SHORT FORM SPECIFICATIONS Provide Blodgett full-size hydrovection oven model HV-100G, (single/double) compartment with fully welded angle iron frame. Each compartment shall have fully welded 304 stainless steel liner. Liner to be covered top and bottom. Unit shall accept five 18" x 26" standard full-size bake pans. Doors shall be triple mounted, black glass with dual pane thermal glass windows with L-E inner glass, curved handle and simultaneous operation. Unit shall be heated by 60,000 BTU gas burner. Air in baking chamber distributed by single inlet blower wheel powered by a four speed, auto-reversing, 3/4 HP motor with thermal overload protection. Each chamber shall be fitted with bright halogen lamps, and five standard stainless steel removable racks. Hand shower mounted to the side of the control for easy cleanup. Unit shall have programmable manual control capable of storing 100 recipes. Control shall feature incremental moisture control, hot air, cool down modes, core probe cook & hold and USB connection. Breaker shut off switch on front panel for easy service. 1 year parts and 1 year labor warranty Provide options and accessories as indicated.

DIMENSIONS:

Floor space

Single 38.1" (968mm) W x 48.7" (1237mm) D
Double Stack 38.1" (968mm) W x 51" (1295mm) D

Interior 29" (737mm) W x 20" (508mm) H x 23.43" (595mm) D
Single on casters Add 4-1/2" (114mm) to height

Product clearance from combustible and non-combustible construction

Oven sides 0" (0mm) Blodgett recommends 4" clearance from any heat source on the control panel side of the oven, an optional heat shield should be considered
Oven back 6" (152mm)

Minimum Entry Clearance

Uncrated 25.6" (650mm)
Crated 30-1/2" (975mm)

GAS SUPPLY (per section):

3/4" NPT

Inlet Pressure:

Natural 7.0" W.C. static to unit
Propane 14.0" W.C. static to unit

Maximum Input:

Single 60,000 BTU/hr
Double 120,000 BTU/hr

POWER SUPPLY (per section):

Standard 115VAC, 10 amp, Nema 5-20R dedicated receptacle
Option 208/240VAC, 5 amp, Nema 6-15 dedicated receptacle
Export Export voltages available on request

Blodgett recommends a Pass & Seymour, model 2097, GFCI due to the use of a variable frequency drive. Must be hard wired in some cases.

NOTE: The company reserves the right to make substitutions of components without prior notice

WATER & DRAIN CONNECTION (per section):

Drain 1.25" O.D. drain connection Maximum drain temperature 140°F (60°C)
Water 3/4" NPT garden hose - cold water only

The drain piping must consist of temperature resistant material, greater than 160°F, and be of adequate diameter not to cause flow restriction. Improper materials may deform and cause restrictions, thus affecting performance.

Appliance is to be installed with backflow protection in accordance with Federal, State or Local codes.

WATER SUPPLY (per section):

Good quality water feed is the responsibility of the owner. Water quality must be within the following general guidelines.

TDS: 40-125 ppm Hardness: 35-100 ppm pH: 7.0 - 8.5
Silica: <13 ppm Chlorides: <25 ppm Chlorine: <0.2 ppm
Chloramine: <0.2 ppm

The best defense against poor water quality is a water treatment system designed to meet your water quality conditions. Blodgett offers optional systems from Optipure.

Water Pressure 30(min)-50(max) PSI

Water Consumption 2.5 - 4.0 GPH based on cooking mode

SHIPPING INFORMATION:

Approx. Weight

Per section 520 lbs. (236 kg)

Crate sizes

30-1/2" (975mm) x 43-1/2" (1105mm) x 56" (1422mm)
(2 crates required for double)