



Project _____
 AIA # _____ SIS # _____
 Item # _____ Quantity _____ C.S.I. Section 114000

UST SERIES - R290

Compact Sandwich Prep Tables with Flat Cover/Self-Contained UST 48" Wide Models



STANDARD PRODUCT FEATURES

- High Quality Stainless Steel Exterior Top, Sides & Door(s)
- Durable, Corrosion Resistant Anodized Aluminum Interior
- Provides NSF Standard 7 Performance, Even When Using 6" Deep Pans
- Standard Work Height 34-3/8" on 4" casters
- Environmentally Friendly, Non-Flammable R-450A Refrigerant
- Top Cut-Outs Accommodate Sixth Size Pans (divider bars and 4" deep plastic sixth size pans provided)
- Reinforced Pan Ledge (holds pans securely level)
- Reversible, Full Length White Nylon Cutting Board
- Self-Closing Stainless Steel Doors with Convenient Stay-Open Feature at 105 Degrees
- Electronic Control
- Two (2) Powder Coated Steel Shelves Per Door, Mounted on Adjustable Pilasters
- Set of Four (4) 4" Casters
- Magnetic Snap-In EZ-Clean Door Gasket(s)

ACCESSORIES & OPTIONS (*field installed)

- CK20 (four 6" (15.2 cm) high casters for 48" models)
- CK24 (four 3-1/2" (8.9 cm) high casters for 48" models)
- CK26 (four 2-3/4" (6.9 cm) high casters for 48" models)
- LK4 (four 6" (15.24 cm) high legs for 48" models)
- SHELF48-UPPER (upper shelf for 48" models)
- SHELF48-LOWER (lower shelf for 48" models)
- Optional accessory kits shipped separately for field installation

FACTORY INSTALLED OPTIONS

- Stainless Steel Finished Back * Other Door Hinging

- GUARANTEED FOR LIFE WORKFLOW DOOR HANDLES



This unit is listed to the applicable UL, CSA and NSF Standards by an approved NRTL. Consult the factory or unit's data plate for approval information.

AVAILABLE CONFIGURATIONS

27", 32", 48", 60" & 72" Wide Models

Model	Model Type	Hinging
UST4808LR-0300	48" Wide 8 Pan Model	Left/Right
UST4808LL-0300	48" Wide 8 Pan Model	Left/Left
UST4808RR-0300	48" Wide 8 Pan Model	Right/ Right
UST4812LR-0300	48" Wide 12 Pan Model	Left/Right
UST4812LL-0300	48" Wide 12 Pan Model	Left/Left
UST4812RR-0300	48" Wide 12 Pan Model	Right/ Right
UST4818LR-0300	48" Wide 18 Pan Model	Left/Right
UST4818LL-0300	48" Wide 18 Pan Model	Left/Left
UST4818RR-0300	48" Wide 18 Pan Model	Right/ Right

Approved by _____ Date _____ Approved by _____ Date _____

MODELS:

UST4812LR-0300

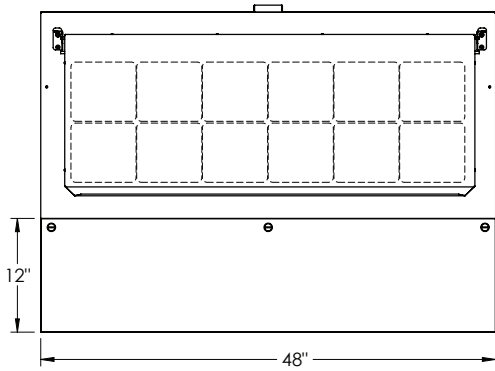

TOP VIEW

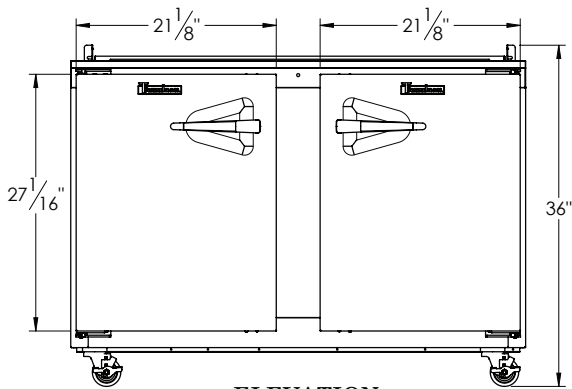
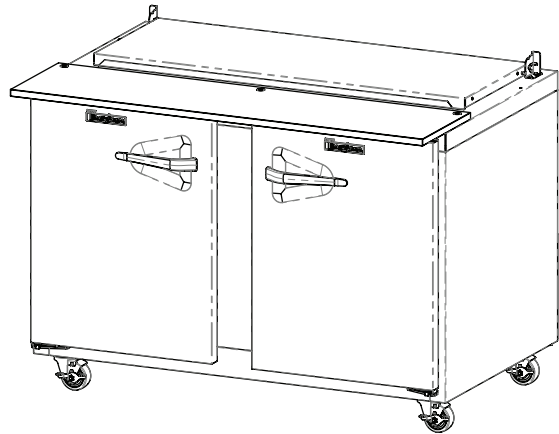

ELEVATION

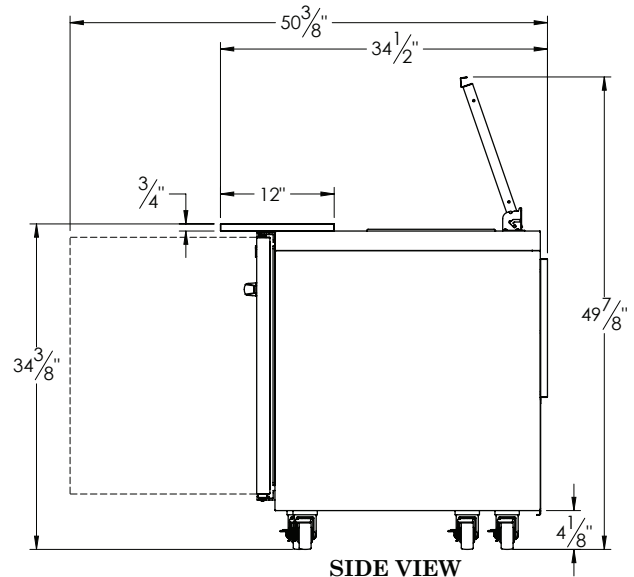

SIDE VIEW

UST SERIES - R290

Compact Sandwich Prep Table

MODELS:

UST4818LR-0300

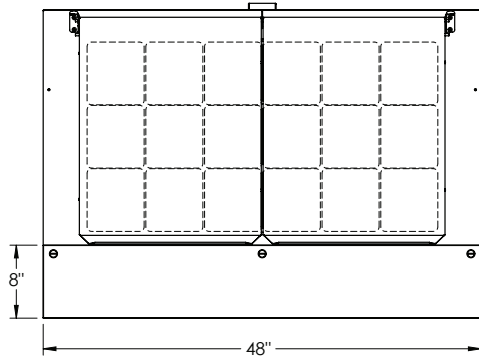

TOP VIEW

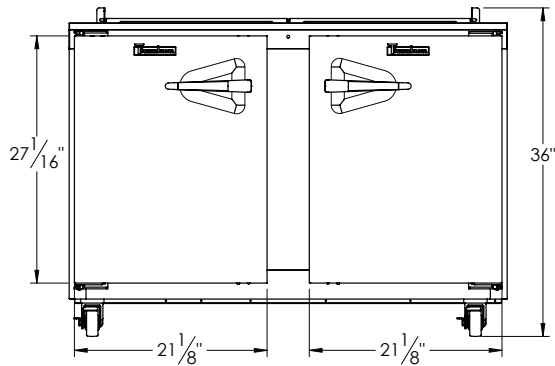
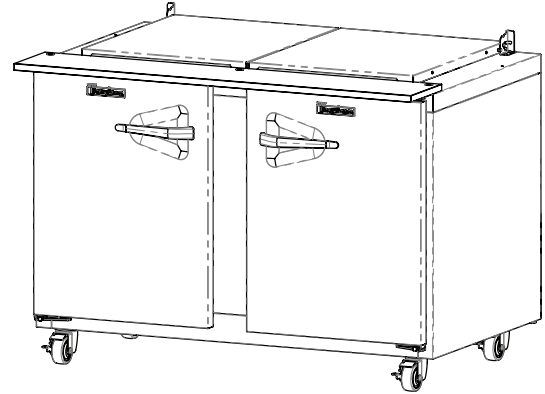

ELEVATION

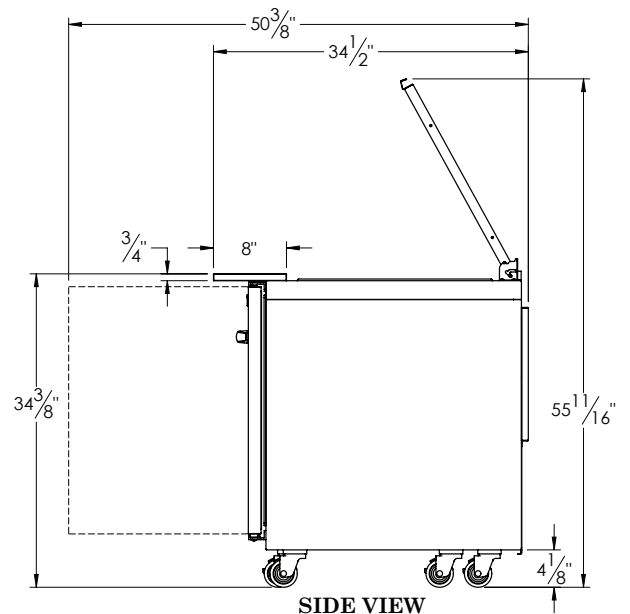

SIDE VIEW



MODELS

Door Models: UST4808LR-0300, UST4808LL-0300, UST4808RR-0300,
UST4812LR-0300, UST4812LL-0300, UST4812RR-0300,
UST4818LR-0300, UST4818LL-0300, UST4818RR-0300,

MODELS	8 Pan Model	12 Pan Model	16 Pan Model
CABINET DIMENSIONAL DATA			
Volume	N/A	N/A	N/A
# of 1/6 Size Pan Top	8	12	18
Width- Cabinet	48"	48"	48"
Width-Door	21 1/8"	21 1/8"	21 1/8"
Depth-door open 90°	50 5/8"	50 5/8"	50 5/8"
Depth-Cutting Board	12"	12"	8"
Height -Lid Open at 70°	16 1/4"	16 1/4"	23 3/4"
Clear Door Opening	18"	18"	18"
# of Doors	2	2	2
# of Shelves	4	4	4
Total Shelf area sq. ft	10.3	10.3	10.3
ELECTRICAL DATA & REFRIGERATION DATA 115/60/1 NEMA 5-15P			
Full Load Amps	7.2	7.2	7.2
MDEC ¹	N/A	N/A	N/A
Refrigerant	R-290	R-290	R-290
Refrigerant Amt oz. (gr)	5 (142)	5 (142)	5 (142)
BTU/HR H.P. ²	1680 1/5	1680 1/5	1680 1/5
SHIPPING DATA			
Width Crated in. (cm)	69" (175)	69" (175)	69" (175)
Volume Crated cu. ft. (l)	69 (1954)	69 (1954)	69 (1954)
Weight lbs. (kg) - Crated	332 (151)	332 (151)	332 (151)

NOTES:

- MDEC = Maximum Daily Energy Consumption
 - Compressor BTU based on a 90°F ambient and 20°F evaporator
- When ordering please specify: Voltage, Hinging, Optional Accessories and any additional warranties.
- This unit may be manufactured in other electrical characteristics and may have additional regulatory agency approvals. Consult factory for other electrical characteristics and agency approvals based on specific electrical and country requirements. (For exact electricals information and approval marks, always refer to the data label of the unit.)

EQUIPMENT SPECIFICATIONS

CONSTRUCTION, HARDWARE, INSULATION

Cabinet exterior front, sides, pan cover lid and doors are constructed of 22 gauge stainless steel. Cabinet interior and door liners are constructed of anodized aluminum. The exterior cabinet back at the bottom are constructed of galvanized steel.

Doors self close at less than 90 degrees and also includes a stay open feature at 105 degrees. Gasket profile and material simplify cleaning and increase overall gasket life.

Both the cabinet and doors are insulated with an average of 2" thick high density non-CFC, foamed in place polyurthane. A 3/4" thick, full-length, reversible white nylon cutting board is supplied standard.

PANS & COVER

Each model is supplied standard with its full compliment of 4" deep plastic 1/6 size pans and stainless steel pan dividers. The lid is constructed of stainless steel, and is easily removable for cleaning.

REFRIGERATION SYSTEM

A balanced, rear mounted, front breathing, self-contained refrigeration system using environmentally friendly R-290 refrigerant is provided. It features a capillary tube metering device, air cooled hermetic compressor, a forced air evaporator coil and a non-electric condensate evaporator. An 8' cord and plug is provided. Standard operating temperature of the refrigerated base is 34° to 38°F (1.1° to 3.3°C).

CONTROLLER

An electronic digital control is supplied standard. It includes a 3-Digit LED display, and a Fahrenheit or Celsius temperature scale display capability.

INTERIOR

Standard interior arrangements include two (2) powder coated wire shelves per door, mounted on pilasters. These are adjustable in 1/2" (1.27 cm) increments, allowing for a minimum of 1-1/2" (3.81 cm) spacing between shelves.

WARRANTY

Both a six year parts and labor warranty and a seven year compressor parts warranty (self-contained models only) are provided standard.

CONTINUED PRODUCT DEVELOPMENT MAY NECESSITATE SPECIFICATION CHANGES WITHOUT NOTICE.