



Project _____

Item # _____

Quantity _____

Maskerade™ Undercounter Induction Warmer

Models: IWRM-UT-06

Hatco's Maskerade™ Undercounter Induction Warmers offer a simple and affordable solution for "invisible" hot food holding under a variety of countertop materials including engineered and natural stone. Perfect for serving applications such as buffet lines and hospitality suites as it eliminates the institutional look of traditional foodwarming equipment while yielding unlimited flexibility.

The warmer has five simple and precise settings, which allow for a wide variety of foods to be held both safely and at optimum quality. The units are also memory retentive, so once turned off and back on, the last setting will resume.

Standard features:

- Can be mounted under a wide variety of countertop materials including engineered and natural stone giving an "invisible" countertop appearance
- Includes one black flexible, highly slip-resistant trivet which locates the chafing dish and protects the stone from the heat of the pan
- Features a control panel with a standby key, temperature control arrow keys a lock key and temperature setting indicators
- Pan Sense Technology (PST) activates the unit only when a suitable pan is placed on the trivet
- Energy efficient, quiet and safe operation
- Features for both safety and convenience, such as the automatic shut-off to prevent overheating
- For easy service, the lower housing can be removed separately
- Includes remote control panel and cord
- 71" (1800 mm) cord with plug and a 79" (2000 mm) control cable



Accessory (available for purchase at any time)

- Additional black, flexible slip-resistant trivets available (one trivet is included). Trivet locates the chafing dish and protects the stone from heat of pan [IWRM-TRIVET]



For operation, location and safety information, please refer to the Installation and Operating Manual.



HATCO CORPORATION | P.O. Box 340500 Milwaukee, WI 53234-0500 U.S.A. | (800) 558-0607 | (414) 671-6350



www.hatcocorp.com | support@hatcocorp.com | [Find a Hatco Rep](#) | [Image Library](#) | [Document Library](#) | [Chat](#)



Maskerade™ Undercounter Induction Warmer

Models: IWRM-UT-06

IWRM-UT-06 Models

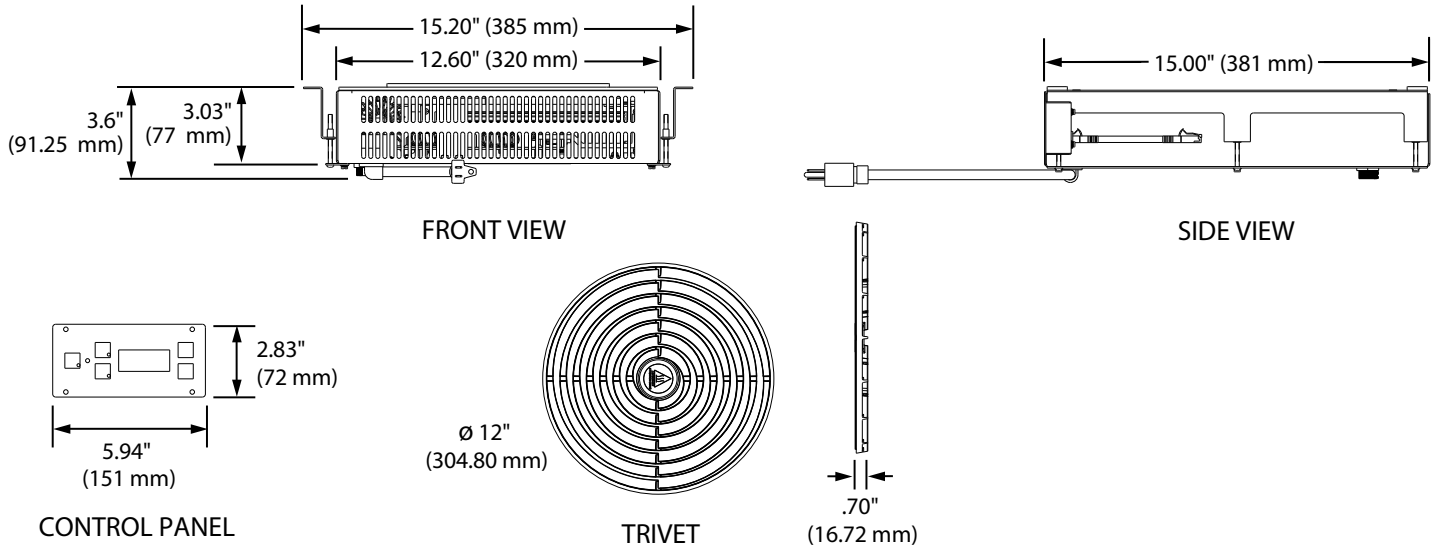

Cutout Dimensions for Control Panel

Model	Width	Height
IWRM-UT-06	5.4" (138 mm)	2.2" (55 mm)

Countertop Materials

Stone	Suggested Materials (not recommended for 100% polymer solid surfaces)	Total Metric Thickness	
		20 mm Dimensions	30 mm Dimensions
Natural Stone	Granite, Marble, Slate		
Engineered	QUARTZ: Cambria®, Caesarstone™, Silestone®, Corian® Quartz (<i>Corian Quartz only</i>), LG Viatera®, Hanstone Quartz, MSI Q, Dekton®, Polarstone® Quartz	20.0 mm countertop material 19.0 mm (¾") plywood 3.2 mm aluminum spacer 42.2 mm overall	30.0 mm countertop material 12.7 mm (½") plywood 42.7 mm overall
Novelty	Concrete, Reconstituted Glass (Neopariés®)		





Maskerade™ Undercounter Induction Warmer

Models: IWRM-UT-06

IWRM-UT-06 Model Ventilation Requirements

Ventilation Requirements: the goal is to for cabinet ambient temperatures to kept as close to room temperature as possible and not exceed 124°F (52°C). This can be easily achieved by providing free access to external air with openings equal to two 20 sq. inch openings per unit installed, one

front and one rear if possible. These can be louvers, screens, etc. See owners' manual for more detailed information.

SPECIFICATIONS Undercounter Induction Warmer

Model	Dimensions (Width x Depth x Height)	Volts	Phase	Watts	Amps	Plug	Cord Location	Ship Weight*
IWRM-UT-06	15.2" x 15" x 3.6" (385 x 381 x 91.25 mm)	120	Single	600	5.0	NEMA 5-15P	Rear left bottom base corner	18 lbs. (8.1 kg)

* Shipping weight includes packaging and is approximate.

The shaded areas contain electrical information for International models

PAN SIZE AND MATERIAL

Maximum Bottom Pan Size: 13" diameter (330 mm), Minimum Pan Size: 5" diameter (127 mm).
Pan Material: Must be a ferrous (magnetic) material.

PLUG CONFIGURATIONS

NEMA 5-15P

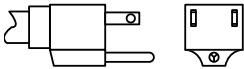

PRODUCT SPECS Maskerade™ Undercounter Induction Warmers

The Undercounter Induction Warmer shall be a Maskerade™ model, manufactured by the Hatco Corporation, Milwaukee, WI 53234 U.S.A. The Undercounter Induction Warmer shall be rated at ... watts, ... volts, single phase and be ... inches (millimeters) in overall width. The Undercounter Induction Warmer shall consist of a stainless steel housing with a painted aluminum base with a single generator coil, a high temperature thermoplastic top surface and rubber trivet with sensor to insure pan is in place before activating heating of the pan. It includes an ON/

OFF button, Preheat button, Up and Down power buttons for 5 power levels, four 14 segment displays and a USB port. A 71" (1800 mm) cord and plug is included. The remote control box is connected to the main case with a 79" (2000 mm) control cable. Warranty consists of 24/7 parts and service assistance (US and Canada only).

HATCO CORPORATION | P.O. Box 340500 Milwaukee, WI 53234-0500 U.S.A. | (800) 558-0607 | (414) 671-6350



www.hatcocorp.com | support@hatcocorp.com | [Find a Hatco Rep](#) | [Image Library](#) | [Document Library](#) | [Chat](#)