



# VACUUM PACKING MACHINE SU-520GP+ CC 120/60/1

Tabletop model. 848 cf/h. 17 + 17"



P/N. 1141127



FOOD PRESERVATION AND SOUS-VIDE  
COMMERCIAL VACUUM PACKING MACHINES

## SALES DESCRIPTION

Two sealing bars (17 + 17").  
848 cf/h Busch vacuum pump.  
Vacuum controlled by sensor.

- ✓ Powered by Busch.
- ✓ Vacuum controlled by sensor.
- ✓ Vacuum PLUS.
- ✓ LCD colour screen: all information at a glance.
- ✓ Backlit touch keyboard.
- ✓ Programmable: 99-programme memory. Blocking option.
- ✓ "Pause" button to marinate food.
- ✓ Phased vacuum programme.
- ✓ Detection of the evaporation of liquids.
- ✓ Double seal.
- ✓ Cordless sealing bar.
- ✓ Bag sealing program.
- ✓ Progressive decompression.
- ✓ Vac-Norm ready with automatic decompression.
- ✓ Stainless steel body and chamber. Deep-drawn chamber.
- ✓ Damped transparent lid.
- ✓ Dry-oil programme for drying the pump.
- ✓ Working hours counter for oil changes.
- ✓ Safety system with protection against vacuum failure.

## INCLUDES

- ✓ Busch pump.
- ✓ Sensor controls.
- ✓ Programmable.
- ✓ Bluetooth connectivity.
- ✓ Vacuum plus: up to 10 seconds of extra vacuum pull.
- ✓ Soft air function.
- ✓ Clear methacrylate lid.
- ✓ Pause function.
- ✓ Liquid detection system.
- ✓ Dry oil cycle.
- ✓ NSF approved.
- ✓ Filling plate.

## OPTIONAL

- Inert gas.
- Sealing plus.
- Printer.
- Vacuum packing bags.
- External vacuum kit for Vac-Norm, containers and accessories.
- Bag cutting kit.
- Support for liquid packaging.
- Additional filling plates.

## ACCESSORIES

- Bag cutting kits
- Filling plates
- Liquid insert plates
- Vac-norm external vacuum kit
- Vac-norm containers
- Smooth bags for vacuum packing
- Trolley for vacuum packing machines
- Thermal labels for CG2 / RB printer
- RB desktop printer for SU vacuum packing machines
- Thermal transfer labels for RB printer
- Vacuum packing machines maintenance kits

## SPECIFICATIONS

Pump capacity: 848 cf/h  
 Bar length: 17 + 17"  
 Total loading: 1.25 Hp  
 Vacuum pressure (maximum): 2 mbar  
 Electrical supply: 120 V / 50-60 Hz / 1~ (13 A)  
 Plug: USA (NEMA 5-15P / 2P+G)

### Internal dimensions

- ✓ Width: 22.3"
- ✓ Depth: 16.9"
- ✓ Height: 8.4"

### External dimensions (W x D x H)

- ✓ Width: 24.9"
  - ✓ Depth: 21.7"
  - ✓ Height: 20.1"
- Net weight: 170.2 lb



SAMMIC, S.L. · Basarte, 1  
20720 AZKOITIA (Gipuzkoa) · SPAIN

Intertek

product sheet  
updated 10/03/2026



# VACUUM PACKING MACHINE SU-520GP+ CC 120/60/1

Tabletop model. 848 cf/h. 17 + 17"



P/N. 1141127

Noise level (1m.): 75 dB(A)  
Background noise: 32 dB(A)

Crated dimensions  
30.9 x 24.1 x 27.0 "  
Gross weight: 189.6 lbs.

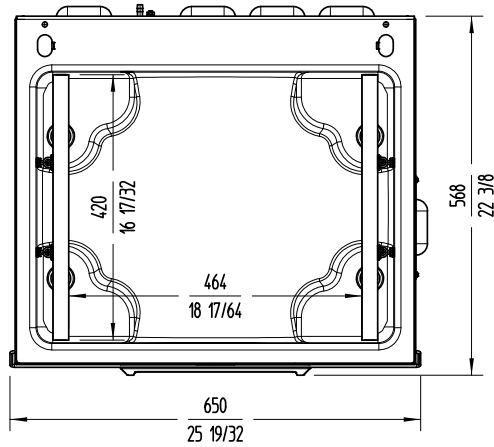
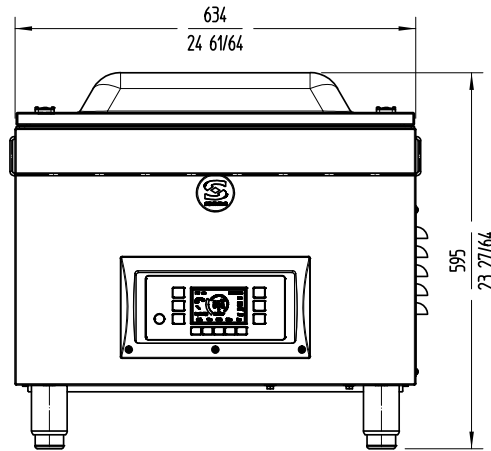
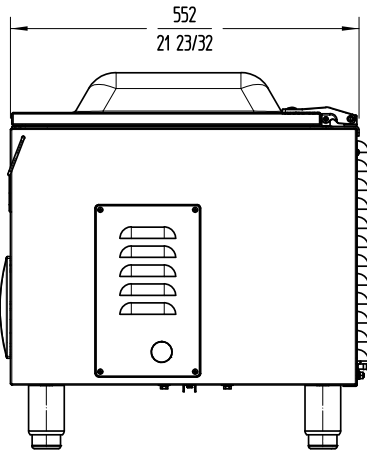

FOOD PRESERVATION AND SOUS-VIDE  
COMMERCIAL VACUUM PACKING MACHINES

**sammic** | sammic.us  
Food Service Equipment Manufacturer

usa@sammic.com    phone +1 (224) 307-2232  
1225 Hartrey Avenue    toll free +1 844 275 3848  
60202-1056 Evanston, IL



Project	Date
Item	Qty
Approved	

product sheet  
updated 10/03/2026