



SERVING THE FOOD INDUSTRY SINCE 1951

## Refrigerated Sandwich/ Salad Prep Tables

ITEM:	50045	50034	50046	50047	50048
MODEL:	PT-CN-0686-HC	PT-CN-0920-M-HC	PT-CN-1194-HC	PT-CN-1524-HC	PT-CN-1778-HC



### Optimize your kitchen and maximize efficiency with Refrigerated Prep Tables.

The Refrigerated Sandwich and Salad Prep Table keeps ingredients fresh and organized with a spacious stainless steel work surface and durable cutting board for prep. Built with heavy-duty casters for mobility, it features eco-friendly R290 refrigerant, Cyclopentane insulation, and a mechanical temperature controller for efficient cooling. Self-closing doors, plastic-coated shelves, and automatic defrost make this unit a practical, reliable choice for any professional kitchen.

- Stainless Steel interior & exterior
- Digital Temperature controller
- Removable door gasket
- Adjustable heavy-duty PVC coated shelves
- Automatic defrost
- Self-closing doors
- Heavy-duty Casters for mobility
- Thick cutting board

Telephone: 1-800-465-0234

Fax: (905) 607-0234

Email: sales@omcan.com

Website: www.omcan.com



Authorized Dealer



Made in China

Updated:  
September 15, 2025 2:28 PM js

Page 1 / 4

TECHNICAL SPECIFICATION					
Features	28" - 1 Door	36" - 2 Doors	47" - 2 Doors	60" - 2 Doors	70" - 3 Doors
Item	50045	50034	50046	50047	50048
Model	PT-CN-0686-HC	PT-CN-0920-HC	PT-CN-1194-H	PT-CN-1524-HC	PT-CN-1778-HC
Capacity	201 L / 7.1 cu.ft	258 L / 9.1 cu.ft	357 L / 12.6 cu.ft	469 L / 16.6 cu.ft	553 L / 19.5 cu.ft
Number of Doors	1 Self-Closing Door	2 Self-Closing Doors			3 Self-Closing Doors
Number of Shelves	1	2	2	2	3
Power	360 W	430 W	490 W	540 W	780 W
Current	3.6 A	4.3 A	4.9 A	5.4 A	7.8 A
Number of Casters	4 Casters				5 Casters
Number of GN Pans	8 x 1/6 Pans	10 x 1/6 Pans	12 x 1/6 Pans	16 x 1/6 Pans	18 x 1/6 Pans
Electrical	110-120V / 60Hz / 1				
Shelf Capacity	88 lbs / 40 kgs				
Shelf Material	Plastic Coated				
Temperature Controller	Digital				
Temperature Range	0.6 - 4.4°C / 33 - 40°F				
Refrigerant	R290				
Insulation Material	Cyclopentane				
Cooling System	Ventilated				
Defrosting	Automatic				
Interior Dimensions	24" x 19.8" x 23.5" / 615 x 504 x 597 mm	33" x 19.8" x 23.5" / 837 x 504 x 597 mm	43" x 19.8" x 23.5" / 1091 x 504 x 597 mm	56.5" x 19.8" x 23.5" / 1434 x 504 x 597 mm	66.6" x 19.8" x 23.5" / 1691 x 504 x 597 mm
Net Weight	176.4 lbs / 80 kgs	220.5 lbs / 100 kgs	253.5 lbs / 125 kgs	319.7 lbs / 145 kgs	343.9 lbs / 156 kgs
Net Dimensions (WDH)	27.5" x 29.5" x 42.3" / 698 x 750 x 1075 mm	36.2" x 29.5" x 42.3" / 920 x 750 x 1075 mm	46.8" x 29.5" x 42.3" / 1188 x 750 x 1075 mm	60.2" x 29.5" x 42.3" / 1529 x 750 x 1075 mm	70.4" x 29.5" x 42.3" / 1787 x 750 x 1075 mm
Gross Weight	216 lbs / 98 kgs	286.6 lbs / 130 kgs	304 lbs / 138 kgs	416.7 lbs / 189 kgs	451.9 lbs / 205 kgs
Gross Dimensions (WDH)	32.7" x 34.6" x 45.7" / 830 x 880 x 1160 mm	41.4" x 34.6" x 45.7" / 1052 x 880 x 1160 mm	52" x 34.6" x 49" / 1320 x 995 x 1245 mm	65.4" x 34.6" x 45.7" / 1660 x 880 x 1160 mm	75.6" x 34.6" x 45.7" / 1920 x 880 x 1160 mm
Plug Type	NEMA 5-15P				

## TECHNICAL DRAWING

Item: 50045- 28"

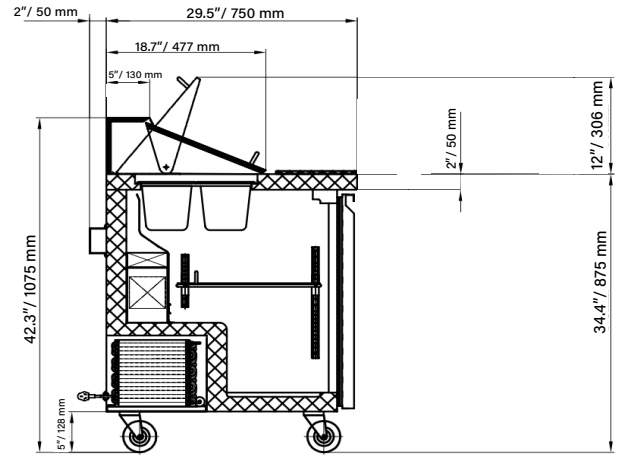
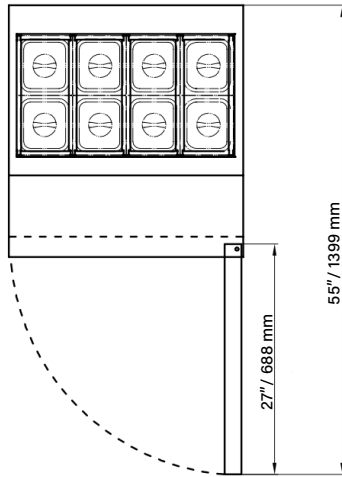
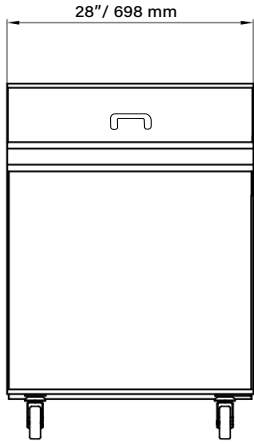

Item: 50034- 36"

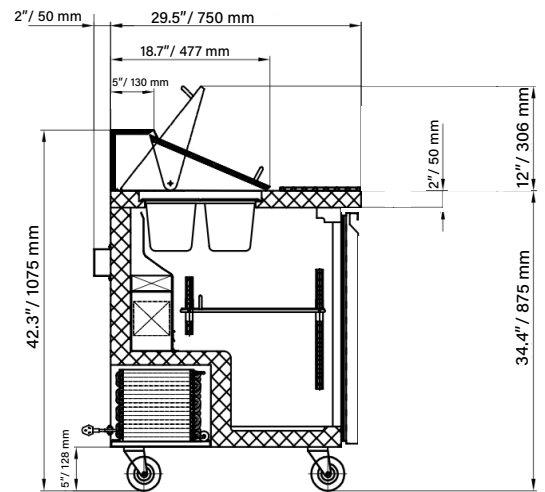
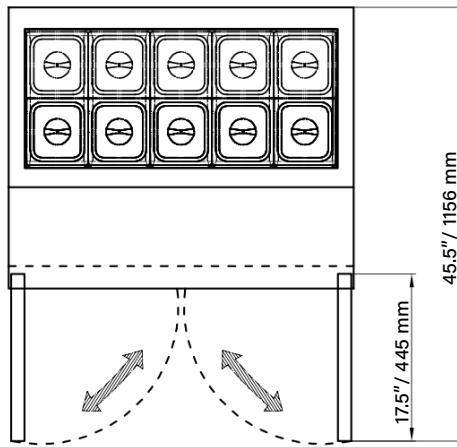
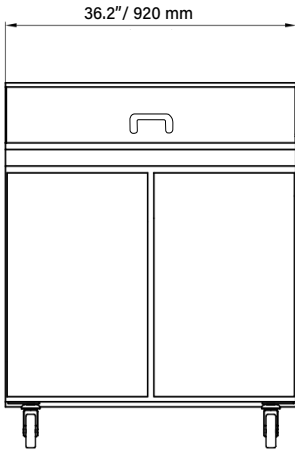

Item: 50046- 47"

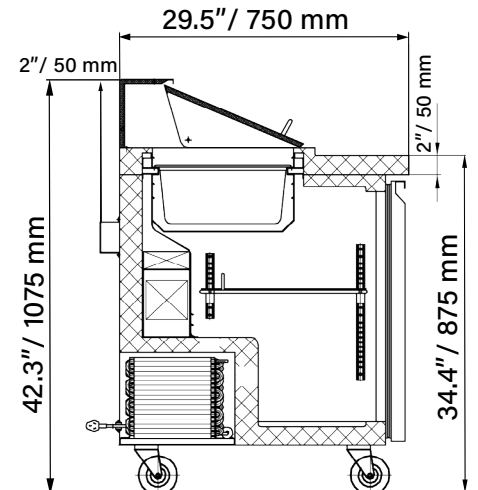
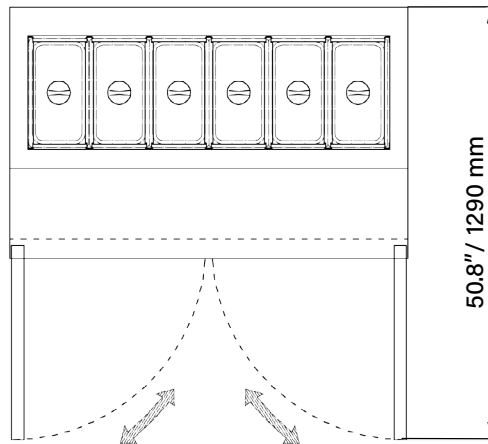
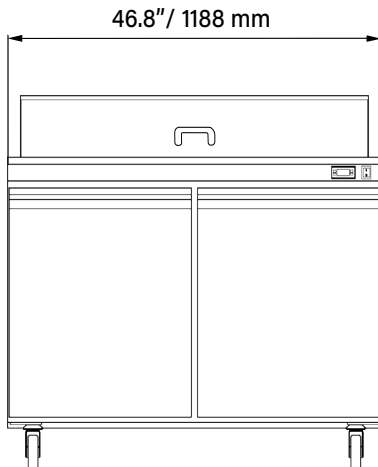



## TECHNICAL DRAWING

Item: 50047- 60"

60.2" / 1529 mm

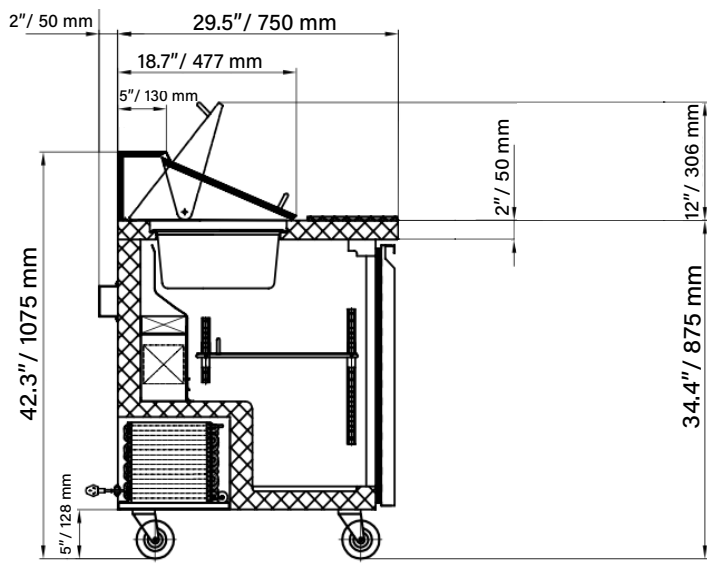
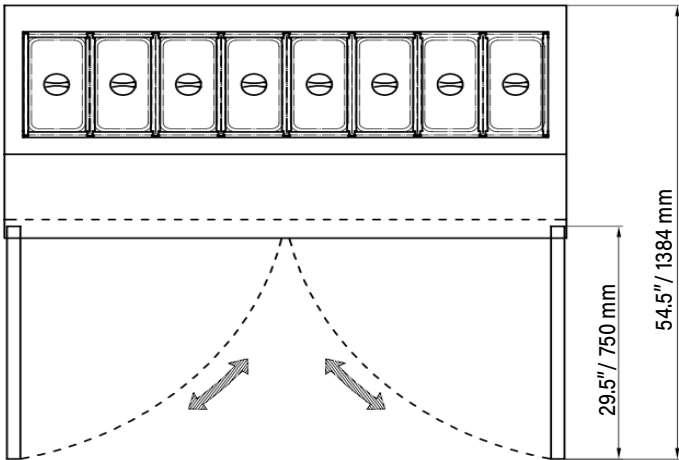
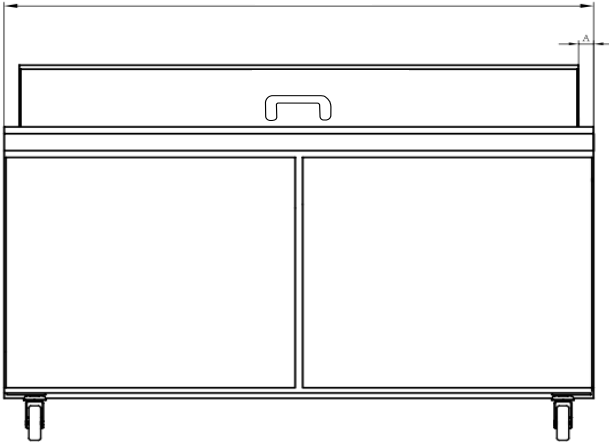

Item: 50048- 70"

70" / 1787 mm

