

# AMERICAN RANGE®

A  Company

Project \_\_\_\_\_

Item # \_\_\_\_\_

Quantity \_\_\_\_\_

## STOCK POTS

GAS TYPE:  NATURAL  LP



ARSP-18  ARSP-18-2

SPSH-18  SPSH-18-2

### STANDARD FEATURES

- ARSP models are 24" in height.
- SPSH models are 18" in height.
- Stainless steel front and sides.
- Cast iron 3-ring burner 90,000 BTU/hr
- Dual control valves, one for inner and middle rings, second for the outer ring.
- Stainless steel pilots for instant ignition
- Full-width removable crumb tray for easy cleaning.
- Heavy gauge construction.
- Chrome plated 6" steel legs, with 3" adjustable bullet feet.
- Two year limited warranty, parts and labor.

### OPTIONAL

- 6" casters



**Model ARSP-18**  
(shown with optional casters)



**Model SPSH-18**  
(shown with optional casters)



A70179 RevC 11212023

# AMERICAN RANGE®

A  Company

13592 Desmond St Pacoima CA 91331  
T. 818.897.0808 Toll Free: 888.753.9898  
[www.AmericanRange.com](http://www.AmericanRange.com)

# ARSP and SPSH STOCK POT



**3-RING  
DUAL CONTROL  
BURNER**

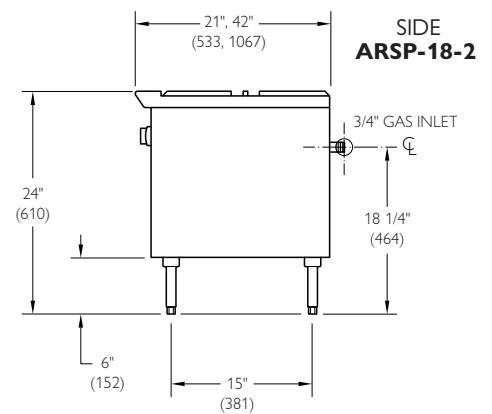
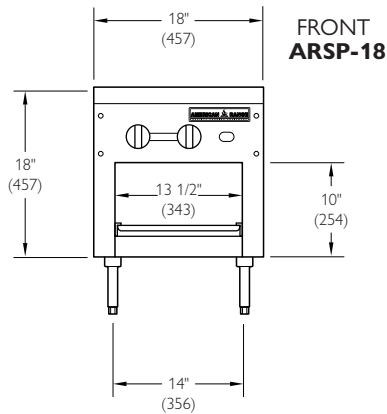

**SPSH-18**

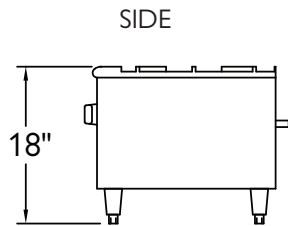
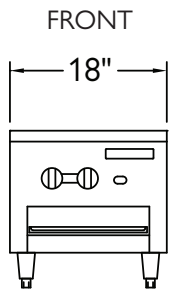
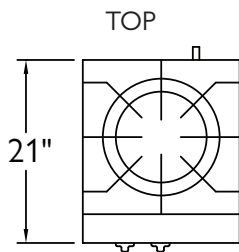

**SPSH-18-2**

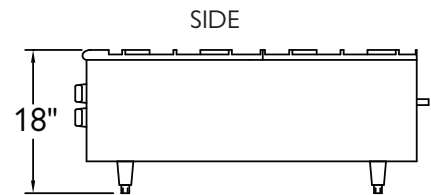
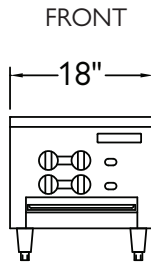
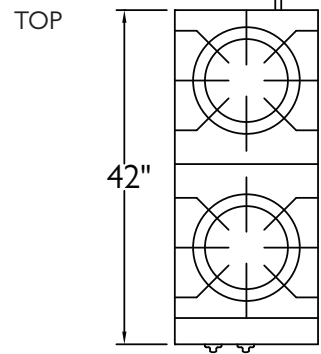

SHIPPING WEIGHT\*

ARSP MODEL	BURNERS	WIDTH (MM)	DEPTH (MM)	HEIGHT (MM)	BTU	(KW)	LBS	(KG)
ARSP-18	3-RING	18" (457)	21" (533)	24" (610)	90,000	(26)	134	(61)
ARSP-18-2	3-RING	18" (457)	42" (533)	24" (610)	180,000	(52)	235	(107)

SPSH MODEL	BURNERS	WIDTH (MM)	DEPTH (MM)	HEIGHT (MM)	BTU	(KW)	LBS	(KG)
SPSH-18	3-RING	18" (457)	21" (533)	18" (457)	90,000	(26)	130	(59)
SPSH-18-2	3-RING	18" (457)	42" (533)	18" (457)	180,000	(53)	230	(104)

- Specify type of gas and altitude if over 2000 feet.
- Please specify gas type when ordering.

### COMBUSTIBLE WALL CLEARANCES:

For use only on non-combustible floors. Legs or casters are required, or 2" (51) overhang is required when curb mounted. Clearance from non-combustible walls is 0". When unit is placed next to combustable walls, clearances must exceed 12" (305) from sides, and 4" (102) from rear.

Commercial cooking equipment requires an adequate ventilation system. For additional information, refer to the National Fire Protection Association's standard.

NFPA96 "Vapor Removal from Cooking Equipment." (NOTE: For North America only)

American Range is a quality manufacturer of commercial cooking equipment. Because of continuing product improvements these specifications are subject to change without prior notice.

NMFCODE: 25970-2 Class: 85

\*Shipping weight includes packaging and is approximate.

NATURAL GAS	MANIFOLD PRESSURE	
	PROPANE GAS	MANIFOLD SIZE
5.0" W.C.	10.0" W.C.	3/4" (19MM)



A70179 RevC 11212023



13592 Desmond St Pacoima CA 91331  
T. 818.897.0808 Toll Free: 888.753.9898  
www.AmericanRange.com