



BEVERAGE-AIR®

PROJECT: _____
 ITEM # _____ QTY: _____
 MODEL # _____
 AIA # _____ SIS # _____
 APPROVED: _____

HORIZON BOTTOM MOUNT FREEZERS

Model: HBF44HC-1-G

GLASS DOOR



**7 YEAR WARRANTY
 Parts, Labor, and Compressor**

CABINET CONSTRUCTION

- Stainless steel front, side, and grille (galvanized back & bottom)
- Stainless steel interior
- Full electronic control with one-touch defrost
- One-piece grille allow easy removal/installation for preventative maintenance
- Self closing door with 120° stay open feature
- LED lighting
- Spring-loaded style hinges
- Plug-in magnetic door gaskets
- Six (6) heavy duty epoxy coated wire shelves
- 6" Casters with two (2) brakes



OPTIONS & ACCESSORIES

- Stainless steel universal tray slide pair, 1 tray slide set for (1) 18" x 26" or (2) 14" x 18" pans (AC)
- 3" Casters or 6" legs
- Door lock
- Epoxy shelves
- Shelf clips
- Remote option* (see note on back page)

REFRIGERATION SYSTEM

- Uses environmentally friendly, energy efficient R290 refrigerant, and meets all regulatory requirements for CARB, SNAP, DOE & more
- Hot gas condensate evaporator
- Adaptive defrost
- Epoxy coated evaporator coil
- Freezer capable of maintaining product temperature down to -10°F



BEVERAGE-AIR®

Horizon Bottom Mount Model: HBF44HC-1-G

PLAN VIEW

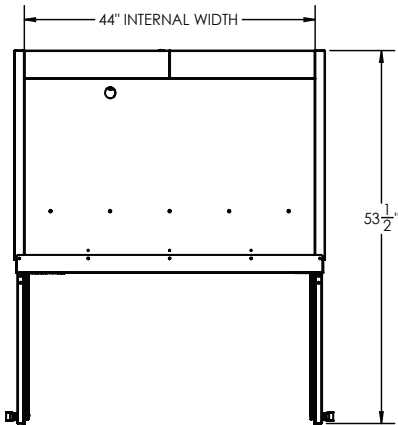

ELEVATION VIEW

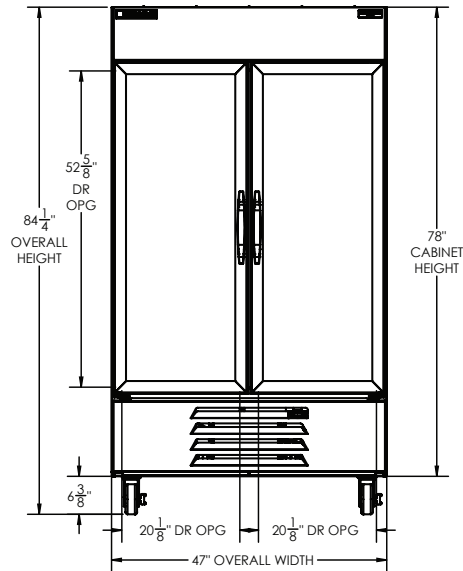

SIDE VIEW

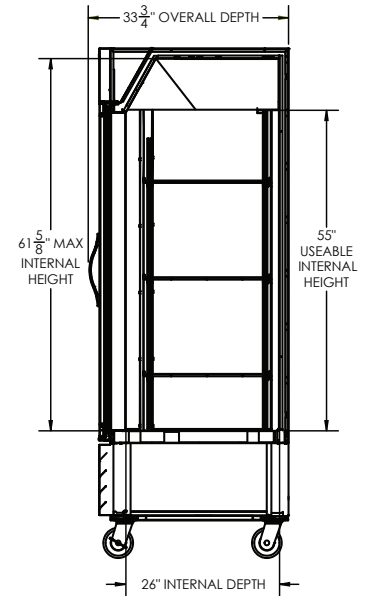

EXTERNAL DIMENSIONAL DATA	
Width Overall (in)	47"
Depth Overall (in)	33 3/4"
Height Overall (in)	84 1/4"
Number of Doors	2
Depth with Door Open 90° (in)	53 1/2"
Door Openings (in)	20 1/8" x 52 5/8"
INTERNAL DIMENSIONAL DATA	
NET Capacity (cubic ft.)	44
Internal Width Overall (in)	44"
Internal Depth Overall (in)	26"
Internal Height Overall (in)	61 5/8"
Number of Shelves	6

*NOTE: Remote units are field wired and come with 6" legs.
Refrigerant must be specified at time of order.

We reserve the right to change specifications and product design without notice. Such revisions do not entitle the buyer to corresponding changes, improvements, additions or replacements for previously purchased equipment. Dimensional tolerances +/- 1/4". Metric dimensions (MM).

Required Clearance: Bottom & Rear 3"

ELECTRICAL DATA	
Full Load Amps	13.9
Voltage	115/60/1
Nema Plug (8' cord)	5-20P
REFRIGERATION DATA	
Horsepower	(2X) 3/4
Capacity (BTU/Hr)	(2X) 2097
Heat Rejection (BTU/Hr)	6291
Charge (lbs/grams/ounces)	(2X) 0.2094 / 95 / 3.35
SHIPPING DATA	
Gross Weight - Crated	588 lbs.
Height - Crated (in)	86"
Width - Crated (in)	49"
Depth - Crated (in)	36"

ELECTRICAL CONNECTION



NEMA 5-20P

115/60/1
NEMA 5-20P

Unit pre-wired at factory
and include 8' long cord
and plug set.

3779 Champion Blvd., Winston-Salem, NC 27105 | 888-845-9800 | Fax: 336-245-6453 | Beverage-Air.com | Sales@bevair.com

Date Issued 3/26 | Printed in U.S.A.