

Cook & Hold Oven

Model 1000-TH

Original Cook & Hold Ovens produce better food quality and higher yields with built-in savings.

Gentle, radiant Halo Heat® technology evenly surrounds food without the use of extremely hot elements, added humidity or fans. This controlled, uniform heat maintains precise temperatures throughout the cooking and holding process—improving food quality and extending hold times.

Cook by time or probe with Simple or Deluxe controls. Probes sense internal product temperature and automatically convert the oven from cook mode to hold mode once set parameters have been reached.

Labor-free, overnight cooking and effortless operation reduces labor costs and increases productivity.

Place anywhere with a ventless, waterless design. Lower costs with energy efficient operation and no water hookups or traditional kitchen hood required. All Alto-Shaam Cook & Hold Ovens are EPA 202 Certified ventless.

Advanced controls – designed intentionally simple – feature an intuitive, user-friendly interface and programmable recipes to ensure consistency with each cook.

ChefLinc™, cloud-based remote oven management software, streamlines processes and maximizes profits with data-driven insights [Deluxe model only].

ISO 9001:2015-certified

Standard Features

- Casters (two [2] rigid, two [2] swivel with brake)
- Single-point, straight removable probe
- Drip tray and drip pan with drain
- Programmable, touchscreen control on Deluxe model
- Programmable control on Simple model
- HACCP data collection on Deluxe model
- Easy recipe upload/download via USB port
- SureTemp™ heat recovery on Deluxe model
- Two [2] stainless steel side racks with fifteen [15] pan positions spaced 1-7/16" [37mm] on centers
- Removable exterior drip tray



CAPACITY

- 4** Full-size hotel pans — 20" x 12" x 2-1/2" on shelves
GN 1/1 — 530mm x 325mm x 65mm
- 8** Full-size sheet pans — 18" x 26" x 1"
Weight maximum: 120 lbs. [54 kg]
Volume maximum: 60 quarts [56.8 liters]
Four [4] shelves included. Additional shelves required for maximum capacity.



On all Cook & Hold heating elements (excludes labor)

ALTO-SHAAM



Shown with Deluxe control



Shown with Simple control

1000-TH

Configurations (select one each)

Models

- Simple
 - HACCP option
- Deluxe
 - Ethernet option [5032090]

Door Choice

- Right hinged, solid door, standard
- Right hinged, window door
- Left hinged, solid door
- Left hinged, window door

Electrical

- 120V, 1Ph
- 208-240V, 1Ph

Casters and Legs

- 2-1/2" [64mm] casters, two [2] rigid two [2] swivel with brake, option [5027134] – not available with bumper
- 2-1/2" [64mm] caster, swivel with brake, option [CS-39969, 4 required] – not available with bumper
- 3-1/2" [89mm] casters, two [2] rigid two [2] swivel with brake, standard [5027133]
- 3-1/2" [89mm] caster, swivel with brake, option [CS-39971, 4 required]
- 5" [127mm] casters, two [2] rigid two [2] swivel with brake, option, [5027112]
- 5" [127mm] caster, swivel with brake, option [CS-39973, 4 required]
- 6" [152mm] legs, set of four [4] [5032092]
- 6" [152mm] seismic legs, set of four [4] [5032093]

Optional Accessories (select all that apply)

Bumper and Handles

- Full perimeter bumper
- Push/Pull handle kit

Additional Probes

- Sous vide probe [PR-36576]
- T-handle probe, up to six [6] with Deluxe [PR-46998]
- Straight probe, up to six [6] with Deluxe (qty one [1] included with oven) [PR-46999]

Drip Pans, Shelves, Holders

- Drip pan with drain [5025893]
- Increased capacity exterior drip pan [5030659]
- Shelf, stainless steel [SH-2325]
- Carving holder, prime rib [HL-2635]
- Carving holder, steamship [cafeteria round] [4459]

Cleaners

- Alto-Shaam, non-caustic cleaner one [1] 32-ounce bottle [CE-46828]
- Alto-Shaam, non-caustic cleaner six [6] 32-ounce bottles [CE-46829]

Accessories, misc.

- Stacking kit, 1000-TH over 1000-TH [5032046]
- Door lock with key [5028755]

Cook & Hold Oven

Model 1000-TH

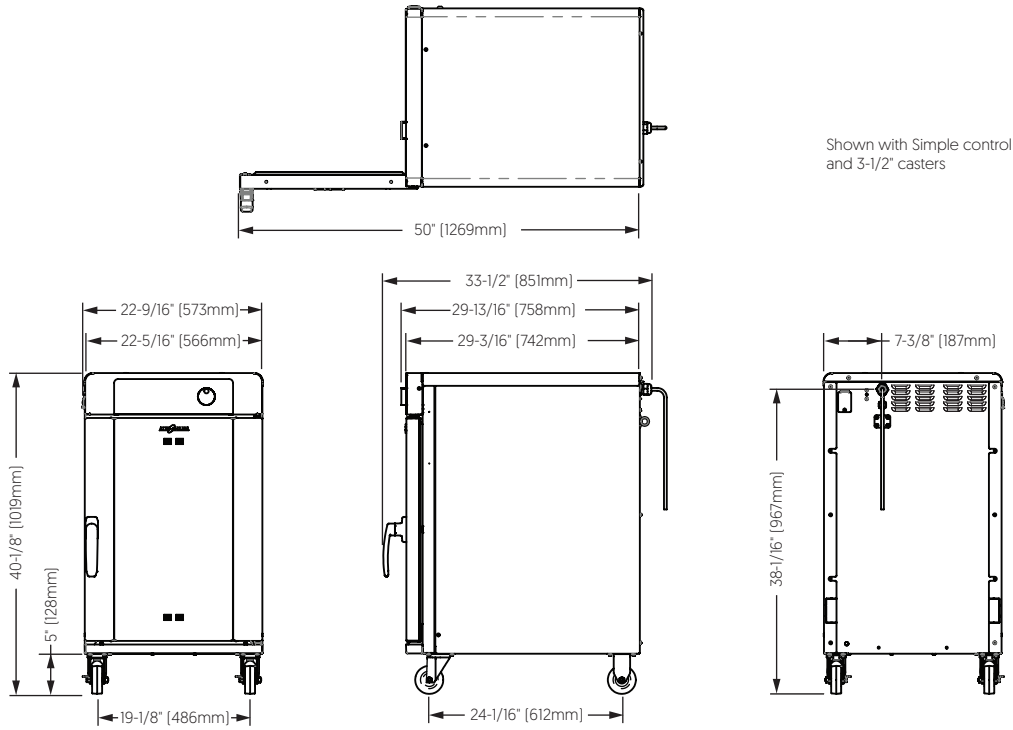

Shown with Simple control and 3-1/2" casters

OVERALL HEIGHT: 1000-TH		
Accessory	in	mm
5" caster	41-3/16"	1046
3-1/2" caster	40-1/8"	1019
2-1/2" caster	38-9/16"	978
6" leg (min)	39-1/16"	991
6" leg (max)	41-5/16"	1048
6" seismic leg (min)	40"	1015
6" seismic leg (max)	42-7/16"	1077

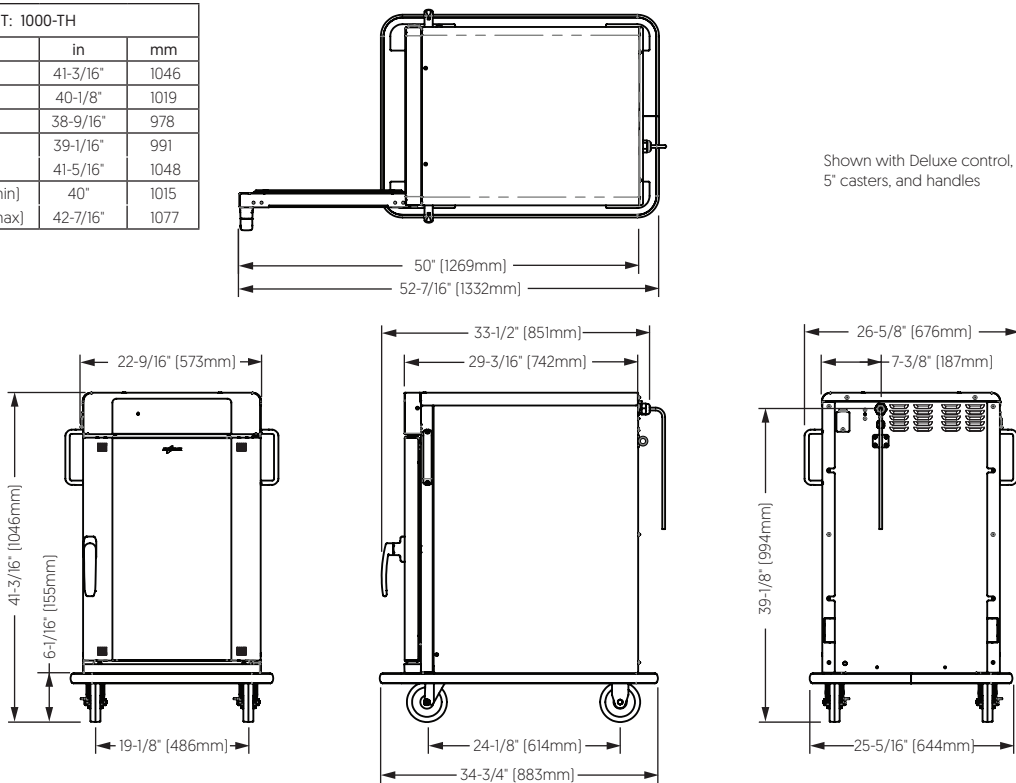

Shown with Deluxe control, 5" casters, and handles

Interior (H x W x D)	Net Weight	Ship Dimensions (L x W x H)	Ship Weight
26-7/8" x 18-7/8" x 26-1/2" [683mm x 479mm x 673mm]	250 lbs. [113 kg]	39" x 39" x 54" [991mm x 991mm x 1372mm]	315 lbs. [143 kg]

Cook & Hold Oven

Model 1000-TH



Top:..... 2" [51mm]
 Left:..... 2" [51mm]
 Right:..... 2" [51mm]
 Back:..... 3" [76mm]

CLEARANCE



The oven must be installed level.
 The oven must not be installed in any area where it may be affected by steam, grease, dripping water, high temperatures, or any other severely adverse conditions.

CHECK FIRST



Heat of rejection

1000-TH	Heat Gain qs, BTU/hr	Heat Gain qs, kW
	831	0.24

HEAT



Cooking temperature range:
 200°F–325°F [94°C–163°C]
Holding temperature range:
 85°F–205°F [29°C–96°C]

TEMPERATURE



1000-TH	V	Ph	Hz	Awg	IEC	A	Breaker (A)	kW	Plug Configuration	Certification
120V	120	1	60	10	—	16	20 UL 30 CSA	1.9	Alto-Shaam offers a number of readily available cord and plug configurations. Contact factory for options.	
208–240V**	208	1	50/60	10	—	15	20 UL 30 CSA	3.1		
	240	1	50/60	10	—	17	20 UL 30 CSA	4.1		
230V	230	1	50/60	10	—	16	32	3.8		
	230	1	50/60	10	—	11	20	2.5*		

ELECTRIC

Electrical connections must meet all applicable federal, state, and local codes.

*Reduced wattage configuration.

**Dedicated circuit required.

CONTACT US

W164 N9221 Water Street | Menomonee Falls, Wisconsin 53051 | U.S.A.
 Phone: 262.251.3800 | 800.558.8744 U.S.A./Canada | Fax: 262.251.7067 | alto-shaam.com