

PROJECT NAME: _____ LOCATION: _____

ITEM: _____ MODEL: _____



(Shown on bin, model CIB400, which is not included.)
Model CIB400 dimensions: 30" W x 31 1/2" D x 40" H
762mm W x 800mm D x 1016mm H

Model **CIM1000** Modular Ice Maker

The CIM1000 is an extremely reliable and efficient commercial ice maker that produces up to 1100 pounds of ice per day. Stainless steel construction provides durability to a unit that is low-maintenance and easy to clean. The unit produces crystal clear ice cubes that work great for applications in restaurants, bars, hotels, grocery stores, and more. Stackable with optional kit. This model is NSF and UL approved for commercial use.



FEATURE LIST

Model:	CIM1000
Description:	Modular Ice Maker
Voltage:	220V/60Hz/1Ph
Ice Type:	Slab Cube
Ice Cube Size:	3/4" x 7/8" x 7/8" 19mm x 22mm x 22mm
Power Consumption:	5.4kWh / 100lbs of ice
Unit Weight:	194 lb / 88 kg
Unit Dimensions:	30" W x 24" D x 33 7/8" H 762mm W x 610mm D x 860mm H
Shipping Weight:	208 lb / 94 kg
Shipping Dimensions:	32" W x 26" D x 34" H 813mm W x 660mm D x 864mm H
Warranty:	See reverse side.

Specifications subject to change without notice.

Approvals: NSF, UL, CE

PLAN VIEW

- Up to 1100 lb (454 kg) daily ice production (based on 50/70° F)
- Produces crystal clear bullet shaped ice cubes
- Stainless steel exterior
- Advanced electronic controls
- Easy to use automatic cleaning setting
- Air-cooled condenser
- Stackable with optional kit
- Designed for commercial use
- Easily mounted on ice bins (ice bin not included)
- Requires use of a drain. Water filter recommended.

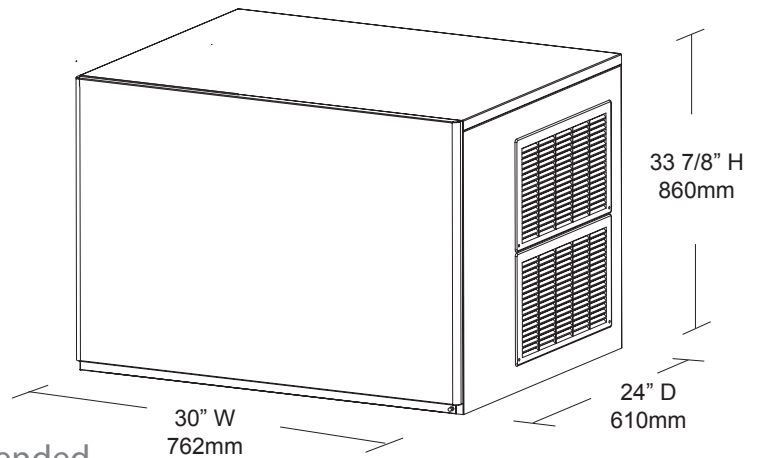
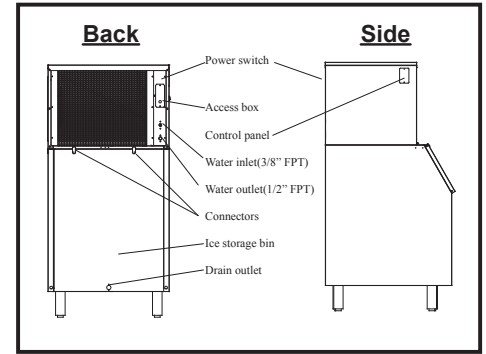

- **Standard Warranty:** 1 Year Parts, 1 Year On-Site Labor, and Additional 4 Year Compressor (part only)
- **Premium Warranty (with confirmed installation of an approved filtration system and proper maintenance of this system according to manufacturer's recommendations):** 3 Years Parts, 3 Years On-Site Labor, Additional 2 Year Compressor (part only) and Additional 2 Year Evaporator (part only)

DIMENSIONAL DATA

Model	Description	Weight	Dimensions
CIM1000	Modular Ice Maker	194 lb / 88 kg	30" W x 24" D x 33 7/8" H 762mm W x 610mm D x 860mm H