



**GAS**

**TUBE FIRED FRYER - 75 lb**



## IFS-75

Shown with included legs



Robotic welding is precise, virtually eliminating leaks.

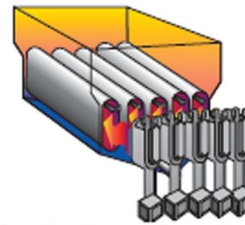

Tube fired burners have a large heat transfer area.

### TUBE FIRED BURNERS

- High efficiency cast iron burners have a large heat transfer area.
- Tubes are constructed of heavy gauge metal with a built-in deflector system.
- 175,000 BTU (51 KW) total output.
- Millivolt temperature control circuit
- Snap acting electronic thermostat has a 200°F - 400°F (93°C - 204°C) temperature range that extends oil life and produces a uniformly cooked product.
- Fast recovery to desired temperature.
- Heats oil quickly producing a better tasting product with less oil absorption.
- 100% safety shut-off

### STAINLESS STEEL FRYPOTS

- Frying area is 18" x 18" (457 x 457mm).
- Frypot tubes and sides are robotically welded stainless steel to virtually eliminate leaks.
- Fine mesh wire crumb screen is included.
- Recessed bottom facilitates draining, slants toward the drain.
- 1-1/4" (32 mm) full port drain valve empties frypot quickly and safely.
- Two large, nickel-plated fry baskets with vinyl coated, heat protective, handles are included.
- Basket hangers are stainless steel.

### EXTERIOR FEATURES

- Stainless steel front, door, sides, basket hanger and frypot.
- Welded and polished stainless steel seams.
- Full heat shield protects control panel.
- Full bottom chassis provides structural support.
- Plate mounted 6" high (152 mm) heavy duty stainless steel legs or optional casters assure secure support.
- One year parts and labor warranty. Limited warranty on frypot, stainless steel frypot is five years pro-rated.

### LARGE COOL ZONE

- Captures and holds particles out of the fry zone
- Reduces taste transfer



1128 Sherborn Street | Corona, CA 92879 | 800.343.7790 | imperialrange.com | imperialsales@imperialrange.com

© 2026 Imperial Commercial Cooking Equipment Imperial reserves the right to change specifications at any time without prior notice and without any obligation for past or future equipment purchases. Visit [www.imperialrange.com](http://www.imperialrange.com) for specification updates



# GAS

## TUBED FIRED FRYER - 75 LB

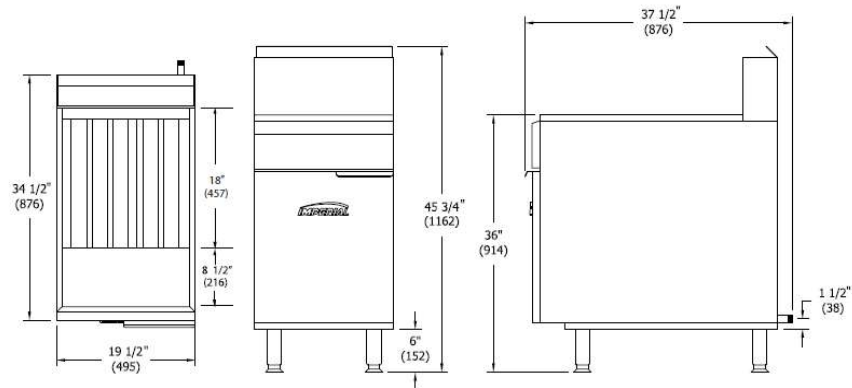

MODEL	OIL CAPACITY	GAS OUTPUT		# OF BURNERS	SHIP WEIGHT (KG) LBS
		BTU	(KW)		
IFS-75	75 lbs. (41 L)	175,000	(51)	5	(122) 270
IF-DS	N/A, drain station	N/A	N/A	N/A	(60) 130

MANIFOLD PRESSURE		MANIFOLD SIZE
NAT GAS	PROPANE	
4.0" W.C.	11.0" W.C.	3/4" (19 MM)

Specify elevation, if over 2,000 ft.

MODEL	FRYER AREA	DIMENSIONS			CRATED DIMENSIONS		
		W	D	H	W	D	H
IFS-75	18" X 18" (457 X 457 mm)	19 1/2" W (495)	34 1/2" D (876)	45 3/4" H (1162)	22" W (559)	37" (940)	35" (889)
IF-DS	N/A, drain station	15 1/2" W (394)	30 1/2" D (775)	44 1/4" H (1124)	17" W (432)	34" (864)	38" (965)

Measurements in ( ) are metric equivalents



**MADE IN USA**

### OPTIONS AND ACCESSORIES

- Fryer drain station with storage cabinet
- Manual timer
- Catering package for easy transporting
- Extra fry baskets with vinyl coated handles
- Gas shut off valve, 3/4" N.P.T.
- Fryer Tip Brush
- Goofer Declogger Rod
- Sediment Scooper
- Quick disconnect and flexible gas hose, 3/4" N.P.T.
- 6" (152 mm) casters

### CLEARANCE REQUIREMENTS

For use only on non-combustible floors. Legs or casters are required for non-combustible floors; or 2" (51 mm) overhang is required when curb mounted. Provide 0" clearance from non-combustible surfaces and 6" (152 mm) from combustible surfaces.

