

W8 TOP

Vacuum pack machines



W8 TOP 40 DX
with inert gas and AOR optionals



W8 TOP 50 DX



- Practical and intuitive touch screen display (see pag.86)
- Electronic control system with pressure sensor for fast and precise processing
- Adjustable automatic vacuum percentage: 50-100%
- Dedicated programs for liquids and marinating
- 10 different settings savable to preference
- 6 selectable languages
- Set up sealing, vacuum, and gas time on a 1-10 sec scale
- Display of vacuum percentage and time to countdown
- Scheduled management of maintenance operations to ensure longer-lasting life oil and filter change warning light
- Thermal pump guard
- Oil preheat and cleaning cycle
- Total rev counter
- Pump meter
- Built-in Wi-Fi card which allows careful management of after-sales service at a distance
- 3-year pump warranty (for machines connected via Wi-Fi)
- Fully manageable via APP that is easy and intuitive and can be downloaded free-of-charge from official stores

Optionals:

Inert gas system (MAP) and soft air
Automatic thermal printer by date, time and packing specifications
A.O.R. Automatic Oil Replacement
SanO3 - Patented - is an integrated and automated sanitizing system that works with an ozone generating cell to deeply sanitize the chamber and all the air pipes reaching the best result where other sanitizing procedures cannot get.
Available only on W8 TOP 40, 50 and 70

Specifications

Plug & Cord: NEMA 5-20 P



Certified to UL Standard 963 and NSF Standard 169
Certified to CSA Standard C22.2

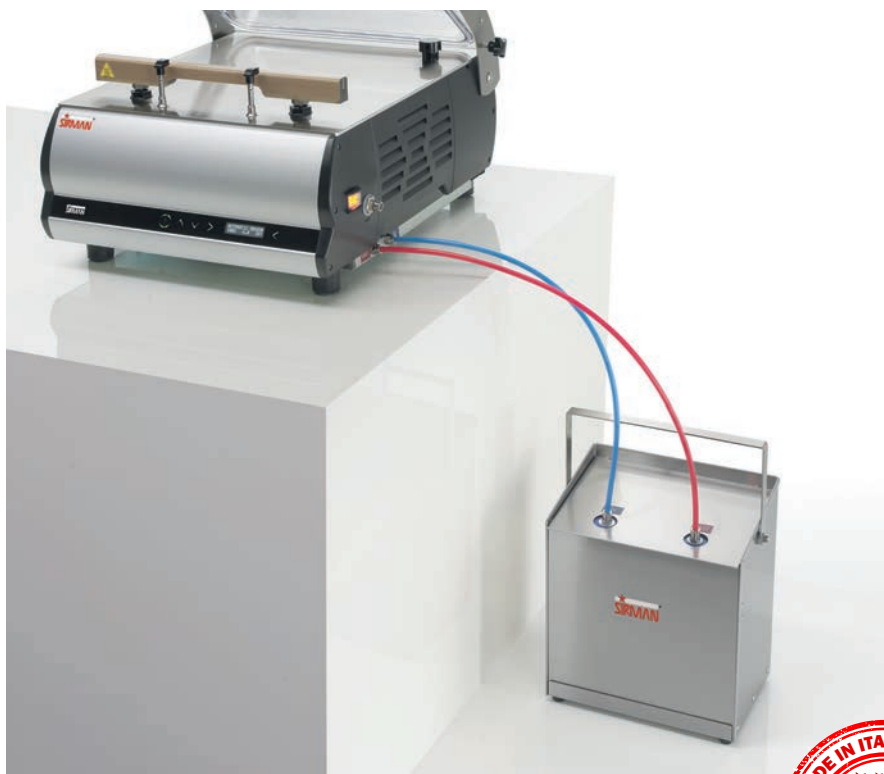

SANO₃
AUTOMATIC OZONE SANITIZATION



Optional - Patented - is an integrated and automated sanitizing system that works with an ozone generating cell to deeply sanitize the chamber and all the air pipes reaching the best result where other sanitizing procedures cannot get. Available only on W8 TOP 40, 50



AOR
AUTOMATIC OIL REPLACEMENT

Automatic Oil Replacement, an exclusive patent by Sirman, always in pole position for vacuum and sous vide technology. The machine automatically manages the oil changing, preserving the pump from damage and thus extending the warranty of the pump to 3 years (for machines connected via Wi-Fi).



Thermal label printer - option



Optional adhesive paper
for built-in printer



Standard support for vacuum bags
with liquids



Easy access for oil change and service



W8 50 DX DB
1 left and 1 right seal bars design



W8 70 DX TB
3 seal bars design



W8 Top 50 DX G
with inert gas flush ready



W8 Top 40-50 DX G
Option inert gas and A.O.R.

External vacuum: hose + GN container + lid



Reinforced Gastronorm Containers
and s/steel Lids



Reinforced Gastronorm Containers and
Lids

		W8 Top 30 DX	W8 Top 40 DX	W8 Top 50 DX DB	W8 Top 50 DX
Bag size	Capacity	Bags/cycle	Bags/cycle	Bags/cycle	Bags/cycle
5" x 7"	.5 pt - .5 lb	2	3	6	4
6" x 8"	.5 pt - .5 lb	2	2	4	3
8" x 12"	1 qt - 2 lb	1	2	4	2
10" x 12"	1.5 qt - 3 lb	1	1	2	2
10" x 15"	3 qt - 6 lb	1	1	2	2
12" x 14"	1 gal - 8 lb	1	1	2	1
12" x 16"	1 gal - 8 lb	1	1	2	1
12" x 18"	1.25 gal - 10 lb	1	1	2	1
14" x 20"	1.75 gal - 14 lb	--	1	2	1
16" x 22"	2.5 gal - 20 lb	--	1	2	1



W8 TOP 70 DX TB

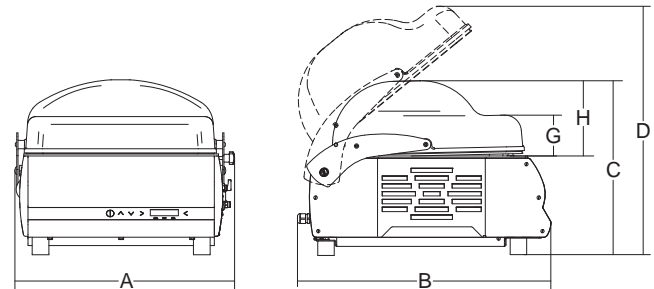

W8 30 - 40 - 50

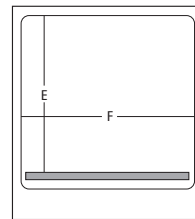

W8 50 DB

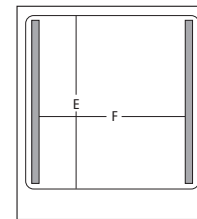

W8 70 TB

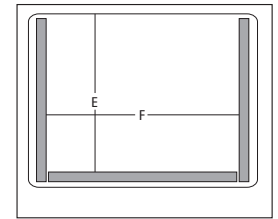

	Electrical	Seal bar	Pump	Chamber dimensions	Chamber dimensions								Net weight	Shipping	Gross weight
					A	B	C	D	E	F	G	H			
		inch.	m3/h	inch.	inch.	inch.	inch.	inch.	inch.	inch.	inch.	inch.	lbs.	inch.	lbs.
W8 Top 30 DX	120V, 11.3 A, 1250W	12 ^{1/4} "	9	13 ^{3/8} "x14 ^{3/16} "x6 ^{3/4} "	16"	20 ^{3/4} "	16"	23 ^{1/8} "	13 ^{1/8} "	13 ^{1/8} "	3 ^{47/64} "	6 ^{11/16} "	83	29"x23"x31"	105
W8 Top 40 DX	120V, 8.7 A, 1150W	16 ^{1/8} "	14	17"x16 ^{1/8} "x7 ^{1/8} "	19 ^{1/2} "	23"	16 ^{5/8} "	24 ^{3/4} "	15 ^{3/8} "	17"	3 ^{47/64} "	7 ^{3/32} "	123	30"x26"x31"	145
W8 Top 40 DX	120V, 11.3 A, 960W	16 ^{1/8} "	24	17"x16 ^{1/8} "x7 ^{1/8} "	19 ^{1/2} "	23"	16 ^{5/8} "	24 ^{3/4} "	15 ^{3/8} "	17"	3 ^{47/64} "	7 ^{3/32} "	123	30"x26"x31"	145
W8 Top 50 DX	120V, 13.8 A, 1000W	20 ^{1/16} "	24	21 ^{1/2} "x18 ^{1/8} "x8 ^{1/4} "	24"	25 ^{1/2} "	16 ^{5/8} "	23 ^{7/8} "	16 ^{7/8} "	21 ^{1/4} "	3 ^{35/64} "	8 ^{17/64} "	155	34"x34"x30"	190
W8 Top 50 DX DB (1 LEFT 1 RIGHT SEAL BARS)	120V, 13.8 A / 1000W	2x16 ^{1/8} "	24	21 ^{1/2} "x18 ^{1/8} "x8 ^{1/4} "	24"	25 ^{1/2} "	16 ^{5/8} "	23 ^{7/8} "	16 ^{7/8} "	21 ^{1/4} "	3 ^{35/64} "	8 ^{17/64} "	165	34"x34"x30"	195
W8 Top 70 DX TB (3 SEAL BARS)	220V, 3-ph +/- 10% 7.3 A, 1750W	1x25 ^{1/4} " 2x16 ^{1/8} "	48	30 ^{3/4} "x19 ^{1/8} "x8 ^{1/4} "	34 ^{1/2} "	26 ^{1/2} "	44 ^{5/8} "	53 ^{7/8} "	16 ^{3/4} "	26"	3 ^{47/64} "	7 ^{7/8} "	370	32"x48"x53"	282

SAT SYSTEM

vacuum pack machines with satellite



- Sat System is an optional function of the TOP control (see pag.86) board that allows you to quickly connect a second satellite machine to the main machine to be used instead of or simultaneously with the main machine.
- With a small investment, you can thus double productivity as if you had two machines available or you can have a satellite machine specifically dedicated to liquid or powdery products (Vertigo SAT 30).
- Ideal for:
 - all health and hygiene situations where the use of different machines for different products is required.
 - those who want to be faster in preparing their vacuum workload
 - those who want to exploit the maximum capacity of the bags with liquid products (using Vertigo SAT 30)
- It is recommended to use satellite units of the same size as the main machine or smaller

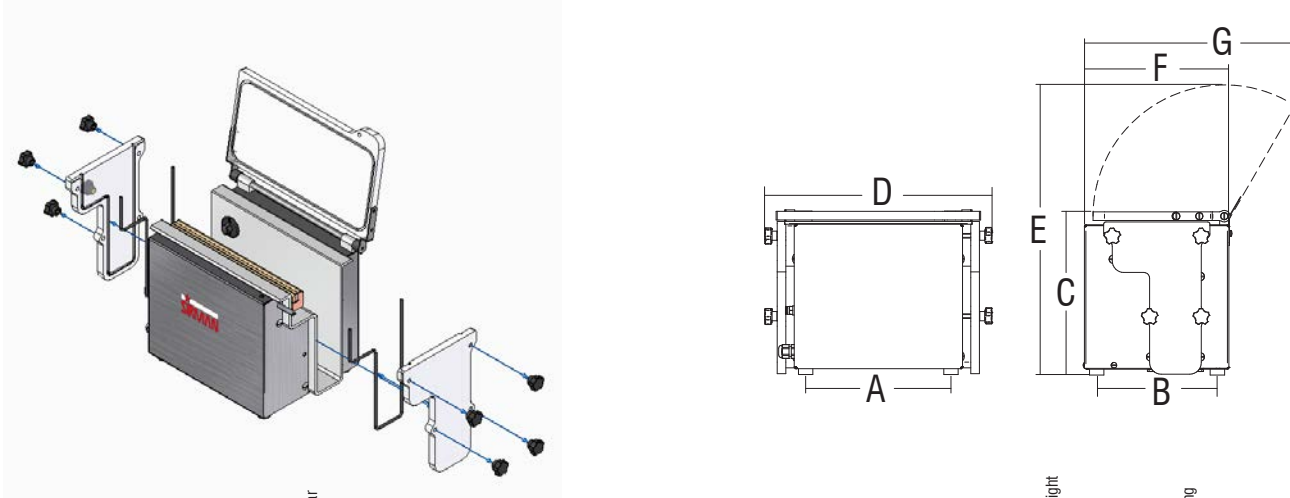

	Seal bar	A	B	C	D	E	F	G	Net weight	Shipping	Gross weight
	inch.	inch.	inch.	inch.	inch.	inch.	inch.	inch.	lbs.	inch.	lbs.
Vertigo SAT 30	12 ¹ / ₄ "	9 ⁶ / ₁₆ "	8 ¹⁷ / ₆₄ "	11 ³ / ₁₆ "	15 ¹⁹ / ₃₂ "	19 ⁷ / ₈ "	9 ⁵⁹ / ₆₄ "	14 ¹³ / ₃₂ "	29		



Certified to UL Standard 963 and NSF Standard 169
 Certified to CSA Standard C22.2

Vacuum-pack machines
 Sous-vide cookers



Sat System ready

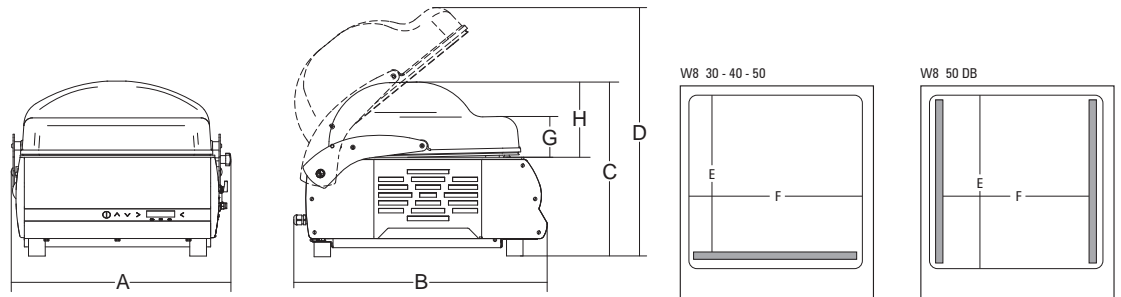

	Seal bar	A	B	C	D	E	F	G	H	Net weight	Shipping	Gross weight
	inch.	inch.	inch.	inch.	inch.	inch.	inch.	inch.	inch.	lbs.	inch.	lbs.
W8 SAT 30	12 ¹ / ₄ "	16"	20 ³ / ₄ "	16"	23 ¹ / ₈ "	13 ¹ / ₈ "	13 ¹ / ₈ "	3 ⁴ / ₇ "	6 ¹ / ₁₆ "	53	29"x23"x31"	75
W8 SAT 40	16 ¹ / ₈ "	19 ¹ / ₂ "	23"	16 ⁵ / ₈ "	24 ³ / ₄ "	15 ³ / ₈ "	17"	3 ⁴ / ₇ "	7 ³ / ₃₂ "	68	30"x26"x31"	90
W8 SAT 50	20 ¹ / ₁₆ "	24"	25 ¹ / ₂ "	16 ⁵ / ₈ "	23 ⁷ / ₈ "	16 ⁷ / ₈ "	21 ¹ / ₄ "	3 ³⁵ / ₆₄ "	8 ¹⁷ / ₆₄ "	99	34"x34"x30"	121
W8 SAT 50 DB	2x16 ¹ / ₈ "	24"	25 ¹ / ₂ "	16 ⁵ / ₈ "	23 ⁷ / ₈ "	16 ⁷ / ₈ "	21 ¹ / ₄ "	3 ³⁵ / ₆₄ "	8 ¹⁷ / ₆₄ "	99	34"x34"x30"	121



SIRMAN USA, Inc. 1500-1514 West Wrightwood Court, Addison, IL 60101 U.S.A.

Phone: +1 847-288-9500
 Toll free: 866-643-6872

sirmanusa@sirman.com
 www.sirman.com



EASY TOUCH Control

- Practical and intuitive touch keyboard with integrated WiFi
- Easy setting of the vacuum and sealing time
- Display shows vacuum percentage and time
- 10 programs that can be stored as desired
- Special programs:
 - Marinade
 - Pump preheating and oil cleaning cycle
 - Timed external vacuum (not for Vertigo)
- Last setting memorization
- Total use cycle and time counter
- Oil change message



TOP Control

- Smart, backlit, comprehensive yet intuitive touch control with WiFi connection
- Electronic control system with pressure sensor for automatic vacuum
 - Vacuum setting at Mbar, Percentage or Time according to the user
 - Temperature control sensor and pump protection
 - Adjustable automatic vacuum percentage 50-100% or with residual vacuum in Mbar
 - Dedicated program for liquids
 - Dedicated programs for marinating
 - 10 Multistep programs that can be stored as desired
 - 6 Languages available
 - Setting sealing time, vacuum and gas with 1/10 sec scale
 - Displays vacuum percentage and remaining time
 - Predictive maintenance operations to ensure a longer duration over time
 - Oil and filter warning signal
 - Oil preheating and cleaning cycle
 - Total cycle counter
 - Pump usage hour counter
 - Electronic Softair with 3 adjustment levels
- This control can integrate the following options*:
- Inert gas system
 - Thermal printer
 - A.O.R.
 - SanO3
 - SAT SYSTEM

* contact our office to find out which options may be available at the same time on the same device