

PASS-THRU REFRIGERATOR

Model: 1RENPTHD

Natural Refrigerant R-290 Model

1-Section Extra-Wide Pass-Thru Refrigerator with Half Doors

1RENPTHD - Stainless steel front, aluminum end panels and interior
1RENSAPTHD - Stainless steel exterior, aluminum interior
1RENSSPTHD - Stainless steel exterior and interior
Designed to maintain NSF-7 temperatures in 100°F ambient.



Options and Accessories

(upcharge and lead times may apply)

Additional epoxy coated steel shelves	Hinged glass doors (consult factory)
Chrome or stainless steel shelves	Full doors
Wine rack	Rehinging of doors (consult factory)
Universal pan slides	Correctional Facility Options
Adjustable legs	<ul style="list-style-type: none"> One way security screws
Custom laminates	<ul style="list-style-type: none"> Locking hasp (lock not included)
Special electrical requirements (consult factory)	<ul style="list-style-type: none"> Stainless steel mesh cover Coverless hinges

Consult factory for other model configurations, options and accessories.



Project Name:

Model Specified:

Location:

Item No:

Quantity:

AIA #:

SIS #:

Standard Model Features

REFRIGERATION SYSTEM

Self contained, performance rated "plug" refrigeration system

Natural, environmentally safe, high efficiency R-290 refrigerant¹

Refrigeration system is readily accessible on top of cabinet, separate from the "food zone"

Automatic, hot gas condensate evaporator

Expansion valve system

CABINET ARCHITECTURE

3" non-CFC polyurethane foam insulation

Smooth, polished chrome workflow door handles

Cam action, lift off hinges

Self-closing doors

Magnetic snap in Santoprene™ door gaskets

Cylinder lock in each door

Heavy duty, epoxy coated steel shelves

Heavy duty pilaster strips

5" casters

MODEL FEATURES

LED interior lighting

Electronic control, off cycle defrost

Top and side air distribution ducts

Cabinet upper side panels and refrigeration "plug" system can be removed and reinstalled at job site

¹ R-290 refrigerant meets all federal and state regulatory requirements.

APPROVAL:

Model Specifications

DIMENSIONAL DATA

Net Capacity (cubic feet)	22 (623 l)
Width, Overall (inches)	28 1/2 (724 mm)
Depth, Overall (inches) (including handles)	38 3/4 (984 mm)
Depth (inches) (less doors)	32 (813 mm)
Depth (inches) (doors open 90°)	84 (2134 mm)
Clear Door Width (inches)	21 7/8 (556 mm)
Clear Half Door Height (inches)	27 1/2 (699 mm)
Height, Overall (inches) (including 5" casters)	82 1/4 (2096 mm)
Number of Doors	4
Number of Shelves	3
Shelf Area (square feet)	20.4 (1.9 sq m)
Tray Slide Capacity (per half section) (2" centers)	11

REFRIGERANT DATA

Condensing Unit Size (H.P.)	1/4
R-290 Refrigerant Charge (oz)	4.3
Capacity (BTU per hour)*	1930

ELECTRICAL DATA

Voltage (International)	115/60/1 (220/50/1)
Feed Wires (including ground)	3
Total Amps (International)	4.3 (2.2)
10 ft. Cord/Plug [attached] (International)	Yes (No)

SHIPPING DATA

Height - Crated (inches)	85 1/2 (2172 mm)
Width - Crated (inches)	31 5/8 (803 mm)
Depth - Crated (inches)	42 (1067 mm)
Volume - Crated (cubic feet)	65 (1841 cu l)
Weight Std - Crated (pounds)	380 (172 kg)
Weight SS - Crated (pounds)	455 (206 kg)

* Rating @ +25°F evaporator, 90°F ambient
Figures in parentheses reflect metric equivalents rounded to the nearest whole unit.

Model Plan Views

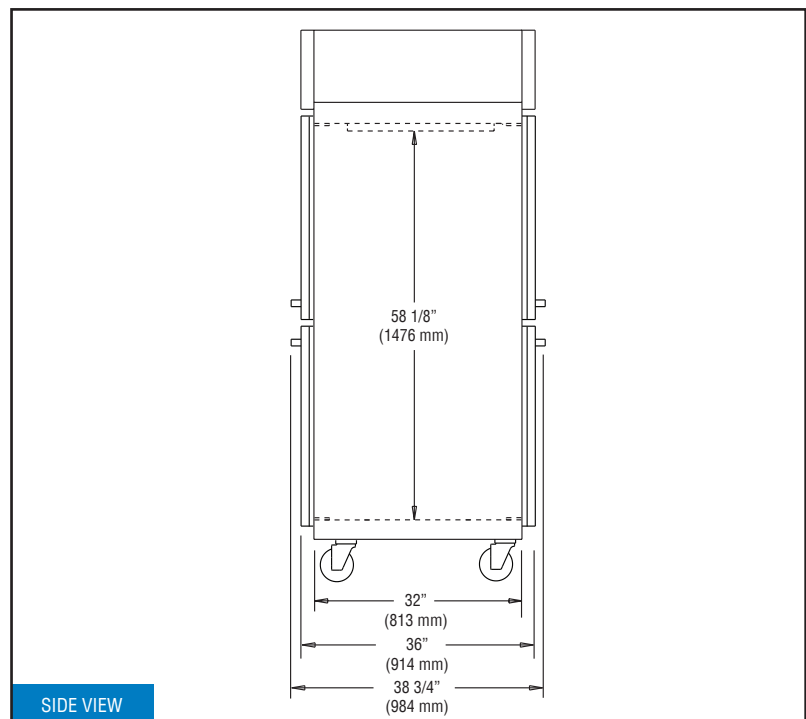
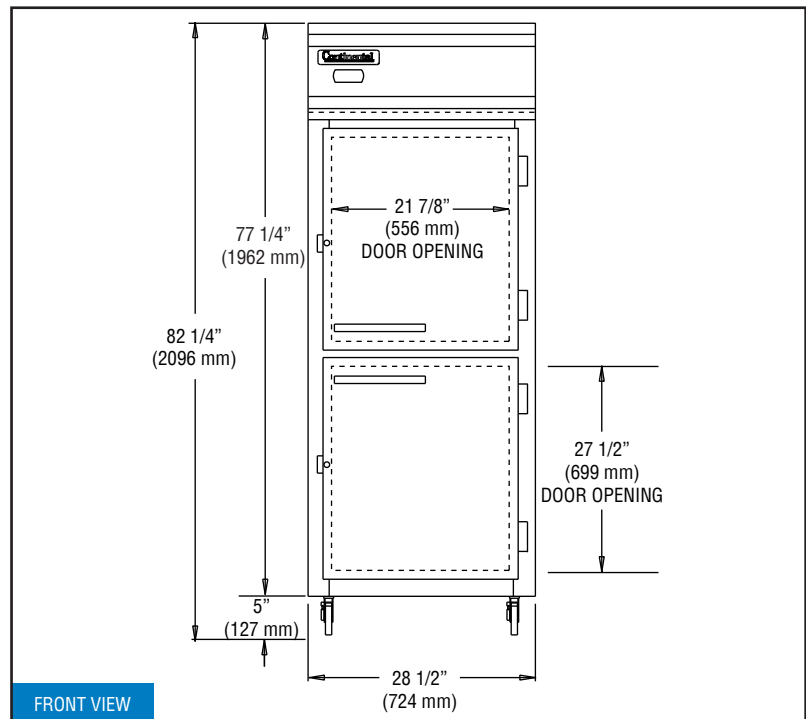

IMPORTANT NOTE: If the cabinet is located under a low ceiling, a minimum clearance of 12" is required on top and 3" on sides.

Continental
Refrigerator

Toll-Free: 800-523-7138
Phone: 215-244-1400
Fax: 215-244-9579

539 Dunksferry Road
Bensalem, PA 19020
www.continentalrefrigerator.com

Due to our continued efforts in developing innovative products, specifications subject to change without notice.



PROUDLY
DESIGNED & ASSEMBLED
IN THE U.S.A.

Intertek

© Copyright 2021. Continental Refrigerator.
A Division of National Refrigeration & Air Conditioning Products, Inc.



Equipped with one NEMA-5-15P Plug
(varies by country)

REVISED: 12/23/25