



TURBO LIQUIDISER TRX-22 220/60/3 (BY AIR)

2-speed turbo-mixer.



P/N 3030505

DYNAMIC PREPARATION
TURBO LIQUIDISERS



SALES DESCRIPTION

- ✓ Turbo-blender designed to work in up to 800 l / 130 gal bowls.

Ideal for big production needs

- ✓ Designed for large yields and for frequent use and cleaning.
- ✓ Mix and liquefy directly in the pot or pan for making consommés, soups, omelettes, sauces, etc.
- ✓ Ideal for kitchens with large production capacities and for food industry.
- ✓ 2-speed model.

Sturdy construction

- ✓ Fully manufactured in 18/10 stainless steel.
- ✓ Designed for large yields.
- ✓ Allow working in containers of up to 800 l / 130 gal.
- ✓ 24" long arm for blending in any type of cooking pot.
- ✓ 0-60 min built-in timer.

Easy and convenient handling

- ✓ They can be moved in several directions and are height-adjustable.
- ✓ The machine is fitted on a trolley with 4 non-slip rubber wheels, 2 of them with brakes.
- ✓ The balanced liquidiser arm stops the arm when falling or tipping back when not locked.
- ✓ An arm securing lever, located on the trolley, allows you to lock the blender with one hand while holding the trolley with the other.
- ✓ The watertight, tilted control panel is easily accessible even during use.
- ✓ Their built-in timer allows leaving the machine running for up to 60 minutes without the need for user involvement.

Versatility, thanks to 3 types of interchangeable grids

- ✓ 21D attachment for fibrous ingredients.
- ✓ Standard 30D multi-use attachment.
- ✓ 42D attachment for very fine blending.

Guaranteed safety

- ✓ The safety micro switch controls work position and prevents the turbine from working if the arm is too high or low.
- ✓ The wiring incorporated into the trolley tubes, so the work area is free of cables and does not hinder the movement of the blender arm.
- ✓ Supports for storing the power supply cable prevent it from getting caught or tangled during storage.

INCLUDES

- ✓ Trolley, motor and arm (without attachments).

OPTIONAL

- Attachments:
 - 21D for fibrous ingredients
 - Standard 30D attachment for general use
 - 42D attachment for very fine blending

ACCESSORIES

- Grids for TRX

SPECIFICATIONS

Maximum recipient capacity: 800 l
 Liquidising arm length: 600 mm
 Max. grid diameter: 288 mm
 Total loading: 2200 W
 Speed (in liquid): 750-1500 rpm
 Electrical supply: - / 60 Hz / 3~ (10 A -)
 Electrical connection: 3P+G

External dimensions (W x D x H)

- ✓ Width: 568 mm
- ✓ Depth: 1643 mm (963 mm)
- ✓ Height: 1219 mm (1651 mm)

Net weight: 96 kg
 Noise level (1m.): <70 dB(A)
 Background noise: 32 dB(A)

Crated dimensions
 1750 x 1040 x 810 mm
 Gross weight: 176 kg





TURBO LIQUIDISER TRX-22 220/60/3 (BY AIR)

2-speed turbo-mixer.



P/N 3030505

DYNAMIC PREPARATION
TURBO LIQUIDISERS

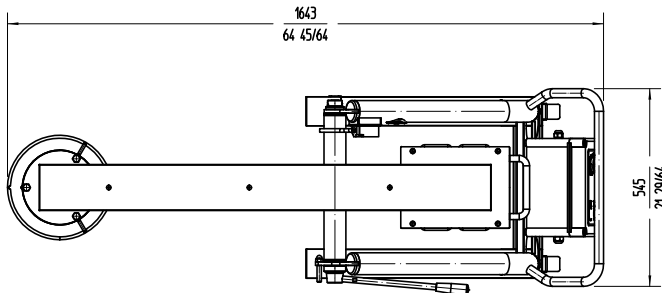
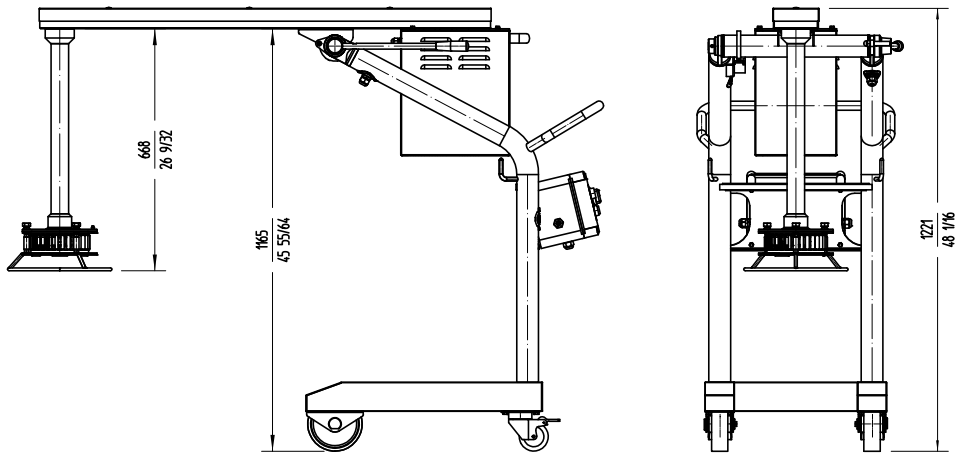

sammic | sammic.com
Food Service Equipment Manufacturer

Polígono Basarte, 1. phone +34 943 15 72 36
20720 Azkoitia, Spain sales@sammic.com



Project	Date
Item	Qty
Approved	

product sheet
updated 14/10/2025