

Easy-Pull™ Heavy-Duty Utility Carts

Model 163421 Patent Pending

Spec. # _____



Provide The Flexibility Of Pushing And Safely Pulling Actions When Hauling Heavy Loads

Benefits

- Push or pull loads for ultimate flexibility
- Multifunctional piece of equipment that helps save money, time, and space
- Transport supplies easily over long distances
- Full visibility when pulling cart to ensure operator safety
- Easy to load and unload cart

Features

- Swing-out handle locks up for conventional pushing action
- All-welded stainless steel construction is easy to clean and sanitize
- Durable 700 lb. carrying capacity
- Optional on-board hitch bar system allows for towing of multiple carts

Casters

- 5" cushion tread, 2 ea. fixed, 2 ea. swivel with brake



Swing-out handle allows for safe pushing or pulling action.



Hinged handle locks securely in upright position.

AIA # _____

Lakeside Manufacturing, Inc.

4900 West Electric Avenue • West Milwaukee, WI 53219 U.S.A.

800-558-8565 • 414-902-6400 • Fax 414-902-6446 • info@eLakeside.com • www.eLakesideFoodservice.com

Model
163421

Easy-Pull™

Heavy-Duty Utility Carts

Specifications:

Lakeside model 163421 is of welded stainless steel U-frame construction. Shelves are 18-gauge and U-frame is 1" x 1" x 1/8" angle stainless steel. Full-height tubular handle is hinged at the bottom to swing out for pulling action, and locks in upright position for pushing action. Optional on-board hitch bar system connects frame crossmembers to allow for towing of multiple carts. Casters are 5" (2 ea. fixed and 2 ea. swivel with brake) non-marking with cushion tread, fastened to reinforced 18-gauge stainless steel crossmembers for extra strength.

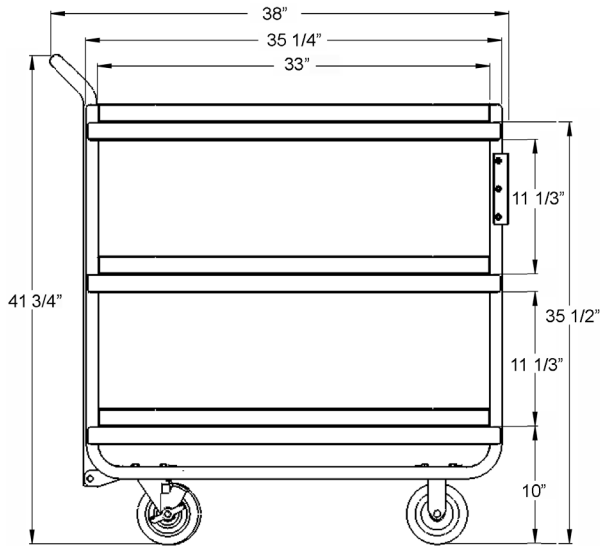

Optional On-Board Hitch Bar

Model 163421

Model Information

| Model | Shelf Size | No. of Shelves | Ship Wt. |
|--------|------------|----------------|----------|
| 163421 | 21" x 33" | 3 Ea. | 125 lb. |

Optional Accessory

- Towing hitch bar



Lakeside Manufacturing, Inc.
4900 West Electric Avenue • West Milwaukee, WI 53219 U.S.A.
800-558-8565 • 414-902-6400 • Fax 414-902-6446
info@eLakeside.com • www.eLakesideFooservice.com