

# DESIGNER LINE SANDWICH UNIT

**Model: D48N12C**

Natural Refrigerant R-290 Model

*Designer Line*

48" Cutting Top Sandwich Unit  
Refrigerator with Solid Door - 12 Pans

Stainless steel front, top and end panels and interior.



## Options and Accessories

(upcharge and lead times may apply)

|                                       |                            |
|---------------------------------------|----------------------------|
| Stainless steel back                  | Casters                    |
| Overshelves (single or double)        | Rear mounted cutting board |
| Additional epoxy coated steel shelves | Composite cutting board    |
| Stainless steel shelves               | Flat insulated night cover |
| Door locks                            | Vision panel lid           |
| Crumb catcher                         | Modified pan openings      |

Consult factory for other model configurations, options and accessories.

Project Name:

Model Specified:

Location:

Item No:

Quantity:

AIA #:

SIS #:

## Standard Model Features

### REFRIGERATION SYSTEM

Performance rated refrigeration system

Natural, environmentally safe,  
high efficiency R-290 refrigerant<sup>1</sup>

Unique air flow distribution allows  
pan product to maintain 33° - 41°F

Automatic, hot gas condensate evaporator

Non-corrosive, plasticized fin evaporator coil

Expansion valve system

Easily serviceable, back mounted compressor

### CABINET ARCHITECTURE

2" non-CFC polyurethane foam insulation

Smooth, polished chrome door handles

Spring loaded, self closing doors

Magnetic snap in Santoprene™ door gaskets

Heavy duty, epoxy coated steel shelves

19" deep, full length nylon cutting board

Insulated lid

Completely enclosed, vented and removable case back

6" adjustable, stainless steel legs

### MODEL FEATURES

Off-cycle defrost

Electronic controller with digital display & hi-low alarm

(12) 1/6 size recessed pans, 4" deep

Removable interior tub below pans

Field rehingeable doors

<sup>1</sup> R-290 refrigerant meets all federal and state regulatory requirements.

**Continental**<sup>®</sup>  
Refrigerator

Toll-Free: 800-523-7138  
Phone: 215-244-1400  
Fax: 215-244-9579

539 Dunksferry Road  
Bensalem, PA 19020  
www.continentalrefrigerator.com

APPROVAL:

# Model Specifications

## DIMENSIONAL DATA

|  |                  |
|--|------------------|
| Net Capacity (cubic feet)                                      | 13.4 (379 cu l)  |
| 1/6 Size Pans (4" deep)  | 12               |
| Width, Overall (inches)  | 48 (1219 mm)     |
| Depth, Overall (inches)<br>(including cutting board & bumpers) | 38 1/4 (972 mm)  |
| Depth, Cutting Board (inches)                                  | 19 (483 mm)      |
| Height, Overall (inches)<br>(including 6" legs)                | 43 1/4 (1099 mm) |
| Shelf Area (square feet)                                       | 6.8 (0.6 sq m)   |
| Number of Shelves  | 2                |
| Number of Doors  | 2                |
| Interior Depth (inches)  | See Drawing      |
| Interior Height (inches)                                       | 26 1/4 (667 mm)  |
| Interior Width (inches)  | 44 (1118 mm)     |

## REFRIGERANT DATA

|                             |      |
|-----------------------------|------|
| Condensing Unit Size (H.P.) | 1/4  |
| Capacity (BTU per hour)*    | 1940 |

## ELECTRICAL DATA

|  |                     |
|--|---------------------|
| Voltage (International)                        | 115/60/1 (220/50/1) |
| Total Amps (International)                     | 4.8 (2.7)           |
| 10 ft. Cord/Plug [attached]<br>(International) | Yes<br>(No)         |

## SHIPPING DATA

|                          |                  |
|--------------------------|------------------|
| Weight (pounds)          | 276 (125 kg)     |
| Height - Crated (inches) | 43 1/4 (1099 mm) |
| Width - Crated (inches)  | 56 (1422 mm)     |
| Depth - Crated (inches)  | 37 1/4 (946 mm)  |

\* Rating @ +25°F evaporator, 90°F ambient  
Figures in parentheses reflect metric equivalents rounded to the nearest whole unit.



Equipped with one NEMA-5-15P Plug  
(varies by country)

**Continental**  
Refrigerator

Toll-Free: 800-523-7138  
Phone: 215-244-1400  
Fax: 215-244-9579

539 Dunksferry Road  
Bensalem, PA 19020  
[www.continentalrefrigerator.com](http://www.continentalrefrigerator.com)

Due to our continued efforts in developing innovative products, specifications subject to change without notice.



© Copyright 2021. Continental Refrigerator.  
A Division of National Refrigeration & Air Conditioning Products, Inc.

# Model Plan Views

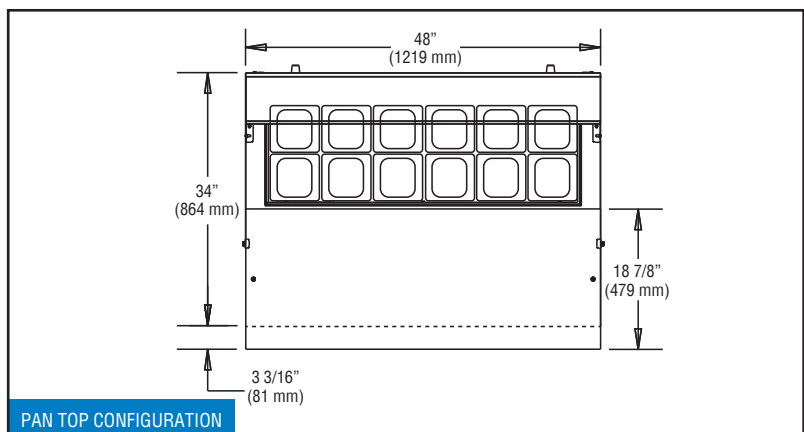
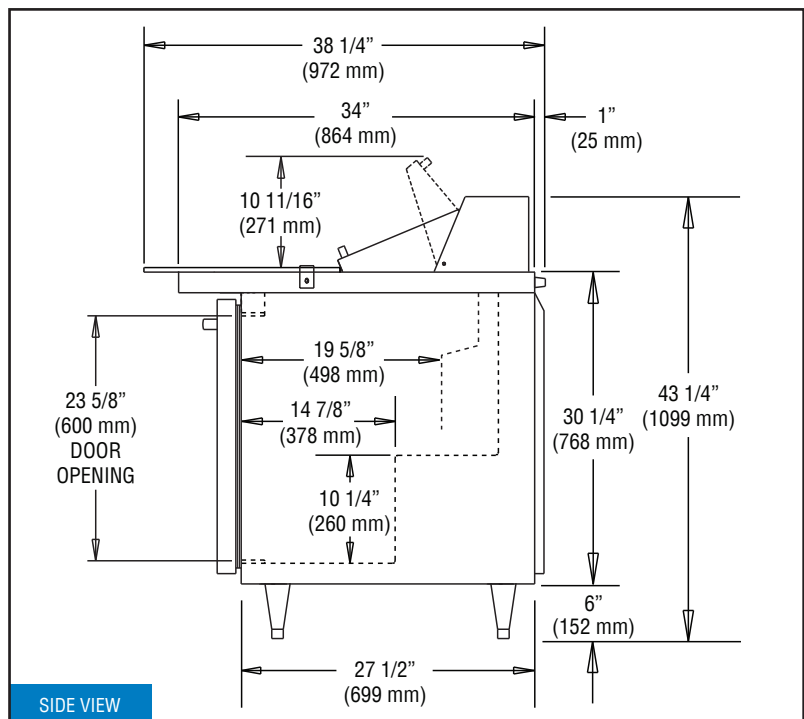
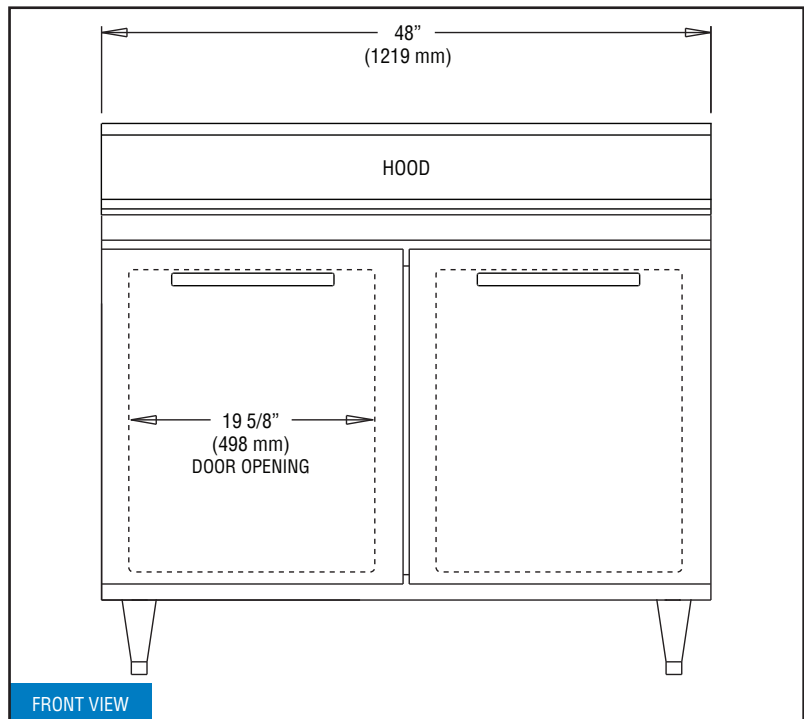

REVISED: 4/5/2022