

# SANDWICH UNIT REFRIGERATOR

## Model: SW32N12M

Natural Refrigerant R-290 Model

### 32" Mighty Top Sandwich Unit Refrigerator with Solid Door - 12 Pans

Stainless steel front, top and end panels, aluminum back and interior.



## Options and Accessories

(upcharge and lead times may apply)

Stainless steel interior	Adjustable legs
Stainless steel back	Optional caster sizes
Overshelves (single or double)	Rear mounted cutting board
Additional epoxy coated steel shelves	Composite cutting board
Stainless steel shelves	Flat insulated night cover
Door lock	Vision panel lid
Crumb catcher	Modified pan openings

Consult factory for other model configurations, options and accessories.

**Continental**<sup>®</sup>  
Refrigerator

Toll-Free: 800-523-7138  
Phone: 215-244-1400  
Fax: 215-244-9579

539 Dunksferry Road  
Bensalem, PA 19020  
[www.continentalrefrigerator.com](http://www.continentalrefrigerator.com)

Project Name:

Model Specified:

Location:

Item No:

Quantity:

AIA #:

SIS #:

## Standard Model Features

### REFRIGERATION SYSTEM

Performance rated refrigeration system

Natural, environmentally safe, high efficiency R-290 refrigerant<sup>1</sup>

Unique air flow distribution allows pan product to maintain 33° - 41°F

Automatic, hot gas condensate evaporator

Non-corrosive, plasticized fin evaporator coil

Easily serviceable, back mounted compressor

### CABINET ARCHITECTURE

2" non-CFC polyurethane foam insulation

Smooth, polished chrome door handle

Spring loaded, self closing door

Magnetic snap in Santoprene™ door gasket

Heavy duty, epoxy coated steel shelf

8" deep, full length nylon cutting board

Insulated lid

Completely enclosed, vented and removable case back

5" casters

### MODEL FEATURES

(12) ½ size recessed pans, 4" deep

Removable interior tub below pans

Electronic controller with digital display & hi-low alarm

Off-cycle defrost

Field rehingeable door

<sup>1</sup> R-290 refrigerant meets all federal and state regulatory requirements.

APPROVAL:

# Model Specifications

## DIMENSIONAL DATA

Net Capacity (cubic feet)	9.0 (253 cu l)
1/6 Size Pans (4" deep)	12
Width, Overall (inches)	32 (813 mm)
Depth, Overall (inches) (including bumpers)	35 (890 mm)
Depth, Cutting Board (inches)	8 (203 mm)
Height, Overall (inches) (including 5" casters)	42 1/4 (1073 mm)
Shelf Area (square feet)	3.9 (0.4 sq m)
Number of Shelves	1
Number of Doors	1
Interior Depth (inches)	See Drawing
Interior Height (inches)	26 1/4 (667 mm)
Interior Width (inches)	28 (711 mm)

## REFRIGERANT DATA

Condensing Unit Size (H.P.)	1/5
Capacity (BTU per hour)*	1625

## ELECTRICAL DATA

Voltage (International)	115/60/1 (220/50/1)
Total Amps (International)	2.46 (1.85)
10 ft. Cord/Plug [attached] (International)	Yes (No)

## SHIPPING DATA

Weight (pounds)	236 (107 kg)
Height - Crated (inches)	43 1/4 (1099 mm)
Width - Crated (inches)	40 (1016 mm)
Depth - Crated (inches)	37 1/4 (946 mm)

\* Rating @ +25°F evaporator, 90°F ambient  
Figures in parentheses reflect metric equivalents rounded to the nearest whole unit.



Equipped with one NEMA-5-15P Plug  
(varies by country)

# Continental®

Refrigerator

Toll-Free: 800-523-7138  
Phone: 215-244-1400  
Fax: 215-244-9579

539 Dunksferry Road  
Bensalem, PA 19020  
[www.continentalrefrigerator.com](http://www.continentalrefrigerator.com)

Due to our continued efforts in developing innovative products, specifications subject to change without notice.



© Copyright 2021. Continental Refrigerator.  
A Division of National Refrigeration & Air Conditioning Products, Inc.

# Model Plan Views

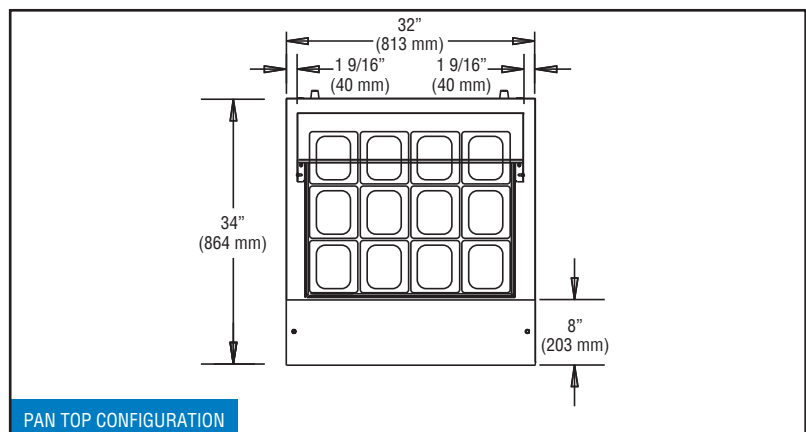
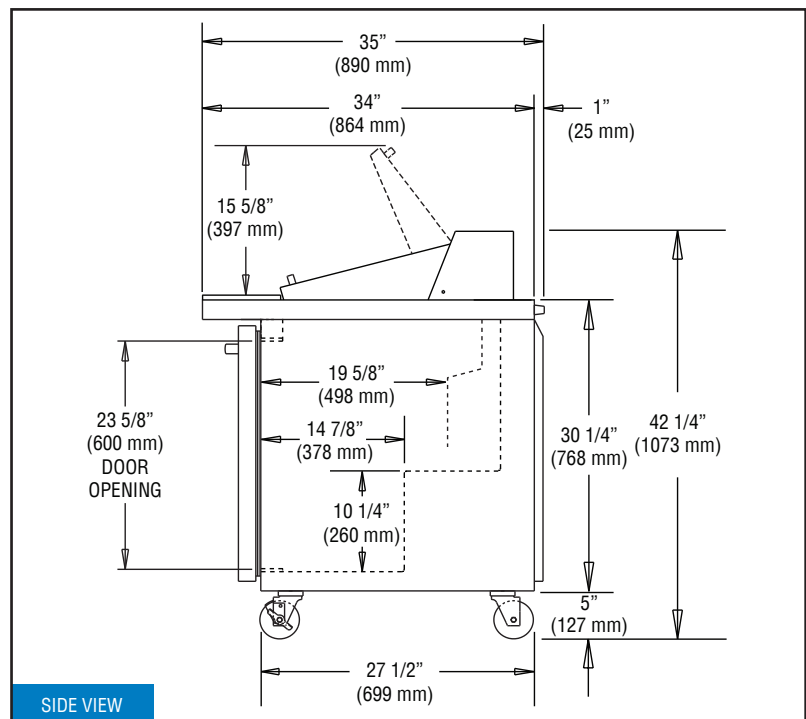
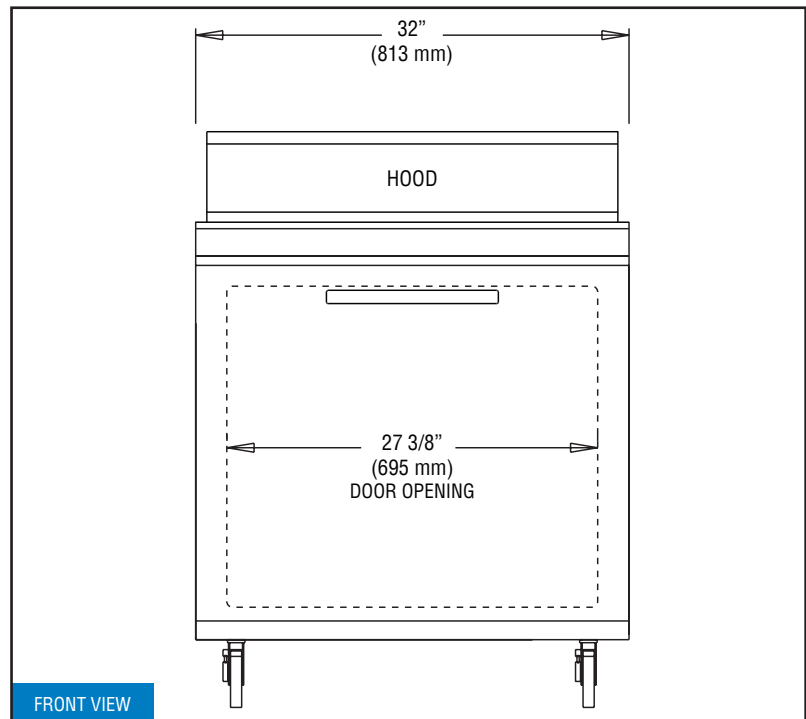

REVISED: 4/8/2022