



SEP-760 Automated Dough Press



Ideal for:

- Pizza
- Tortillas
- Pita Bread
- Burritos
- Roti
- Chapati
- Flat Bread
- Gluten-free Products
- Ethnic Foods

Highlights:

- Press products up to 18"
- Extra height between platens allows easy operation
- 300-500pcs an hour
- Compact tabletop design
- Simple thickness adjustments
- Heavy duty, maintenance-free
- All electric heavy duty drive
- Efficient energy consumption
- Non-stick work surfaces

SEP-760 Automated Dough Press

Features

- Simple heat settings for top & bottom platens
- Switch to automated or manual mode
- Programmable “dough tap” for optimal doughspreading
- Patented Design for even dough stretching
- Programmable PRESS TIMER
- Programmable BUZZER
- Dough piece COUNTER
- Programmable ECO MODE to conserve energy

Industry Uses

- Pizzerias
- Restaurants
- Cafes
- Supermarkets
- Schools
- Mexican Establishments
- Ethnic Food Production

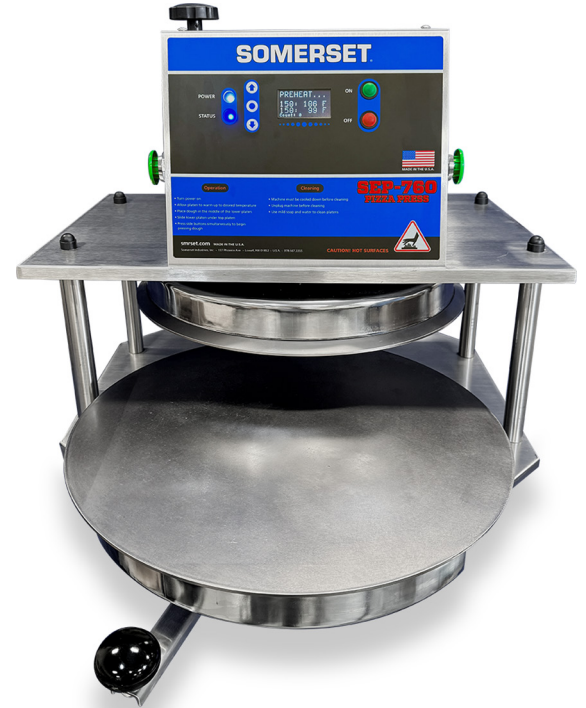

Specifications

(Specifications subject to change without notice)

Electrical Data: 220v / 50-60Hz 3600W 16A

Plug Configuration: NEMA 6-20P 

Temperature Range: 0-400° F (0-204° C)

Construction: All Stainless Steel

Shipping Weight: 243lbs (64.8kgs)

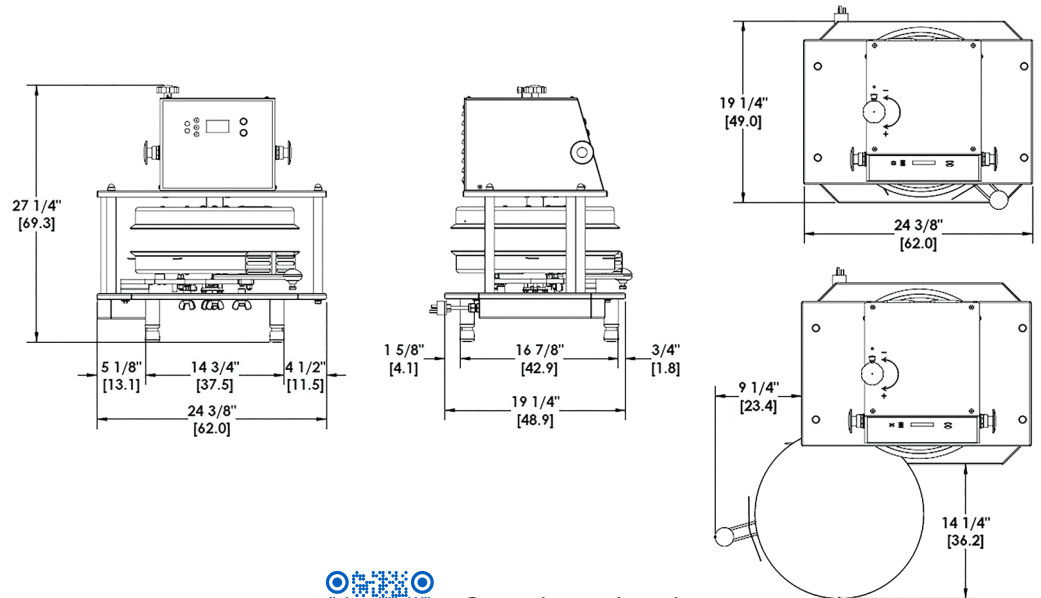

Contact us

978.667.3355 | 800.772.440

Fax: 978.671.9466

Email: somerset@smrset.com

smrset.com

Somerset Industries, Inc.
137 Phoenix Ave
Lowell, MA 01852 USA



Scan the code to learn more about the SEP-760