

Project:	
Model #:	
Item #:	
Available W/H:	Qty:
Approval:	
AIA #:	SIS #:
CSI Section 11400	

Buffet Display Table

Food Prep Tables
J Series

Model : JBT-60-N



* Sneeze guard sold separately

FEATURES & BENEFITS

- **Digital temperature control & monitor system**
 Keeps food products safe by maintaining constant temperatures. External digital display allows for easy monitoring.
- **Hydrocarbon refrigerants (R-290)**
 With innovative and eco-friendly technology, Turbo Air brings you hydrocarbon refrigerators designed to meet DOE's Energy Conservation Standards in 2017 and to use EPA's SNAP Program approved HC refrigerants. Hydrocarbon refrigerants do not deplete the ozone layer and have very low contribution to global warming (ODP-0, GWP-3).
- **Exterior & interior of the cabinet**
 The Turbo Air J series boasts all stainless steel exterior including back (galvanized steel bottom). Interior is stainless steel floor with AL sides, back and AL door liners. It guarantees the utmost in cleanliness and long product life. The J series adds a touch of style to the most refined setting.
- **Side mount compressor unit**
 With compressors positioned on the side of the unit, our refrigerators can now be serviced without being moved. Our front air intake feature also allows this model to be highly efficient in narrow spaces.
- **High-density polyurethane insulation**
 The entire cabinet structure and solid doors are foamed-in-place using high density, CFC free polyurethane insulation.
- **Adjustable, heavy duty, PE (polyethylene) coated wire shelves**
- **Ergonomically designed doors**
 Customers' fatigue fades away with easy grip handles and doors that open effortlessly. These features along with self-closing doors make this the ultimate choice in customer convenience.
- **Magnetic door gaskets**
 Magnetic door gaskets are of one-piece construction, removable without tools for ease of cleaning and replacement.
- **Easy open front grille with condenser cleaning brush kit**
 Front grille cover is easily removable without any tools, which makes condenser cleaning easy and convenient at any time. Handy condenser cleaning brush is included inside the front grille cover.
- **Double sided polycarbonate sneeze guard (optional)**
 The transparent polycarbonate cover is durable, and the two 304 stainless steel side stands are easy to clean and anticorrosive.
- **Refrigerator holds 33°F ~ 39°F for the best in food preservation**



Model	Swing Doors	CU./FT.	#of Shelves	#of Pans (1/3 size)	HP	AMPS	Crated Weight (lbs.)	L x D x H* (inches)
JBT-60-N	2	15	2	12	1/2	6.2	235	59 1/8 X 27 1/2 X 29

Buffet Display Table

Food Prep Tables
J Series

Model : JBT-60-N

ELECTRICAL DATA	
Voltage	115/60/1
Plug Type	 NEMA 5-15P
Full Load Amperes	6.2
Compressor HP	1/2
Cord Length (ft.)	9
Refrigerant	R-290
DIMENSIONAL DATA	
Ext. Length Overall (in.)	59 1/8 (1502mm)
Ext. Depth Overall (in.)	27 1/2 (700mm)
Ext. Height Overall (in.)*	29 (736mm)
# of Doors	2
# of Shelves	2
# of Pans	12
Net Capacity (cu. ft.)	15
Shelf Size (in.)	21 1/2 x 17 3/4
Net Weight (lbs.)	200
Gross Weight (lbs.)	235

Design and specifications subject to change without notice.
Actual shipping weight may differ due to extra packing materials for product protection.
* Height does not include 5" for caster with stem height.

■ **WARRANTY : 2 Year Parts and Labor Warranty
5 Year Compressor Warranty**

■ **STANDARD FEATURES**

- *Anti-corrosion coated evaporator*
- *Self-contained system*
- *4" dia. swivel casters with locks on the front set*
- *1/3 size condiment pans included*

■ **OPTIONAL ACCESSORIES**

- 1" caster, 1/2" diameter & 13 TPI: S28R813660 (non-brake)
- 2.5" caster, 1/2" diameter & 13 TPI: 30265H0100 (non-brake), 30265H0200 (w/ brake)
- 5" caster, 1/2" diameter & 13 TPI: M726500100 (non-brake), M726500200 (w/ brake)
- Leveling leg, 1/2" - 13 TPI x 1.54": LFM1213566
- 6" ABS plastic leg: 30221M0200
- 6" stainless steel leg: 30221M0600
- Additional PE coated wire shelf: BR99000102
- Sneeze guard: SNZ-60T
- Tray slide: TS-60
- Clear pan cover: PC-60J
- Cutting board: CBJB60
- **Door lock: extra lead time will apply, please call factory for more details to order**

PLAN VIEW

(unit : inch)

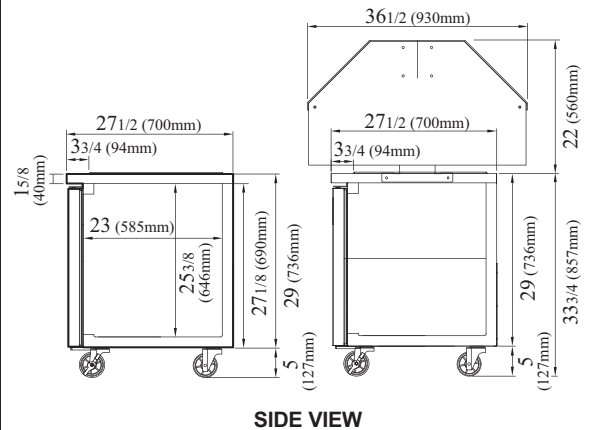
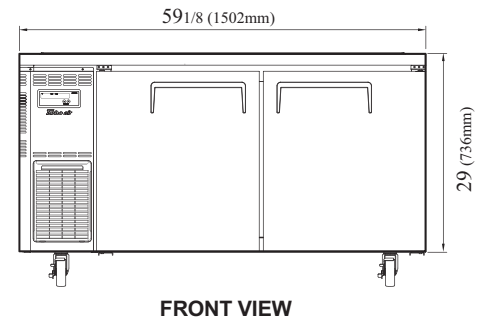
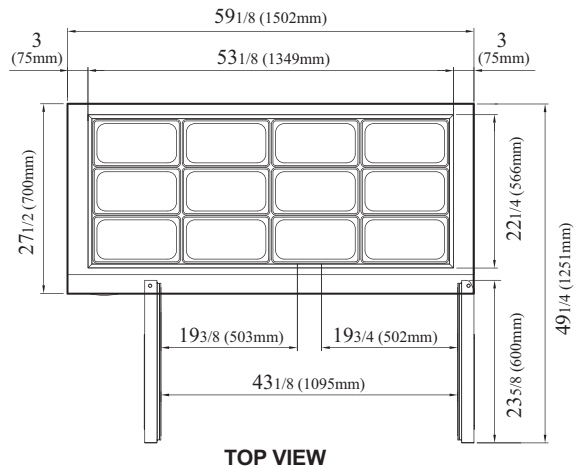

Ver.20260611



- Turbo Air : 800-627-0032
- Bake Tech Innovation : 800-500-3519
- Warranty: 800-381-7770
- AC: 888-900-1002



Continued product development may necessitate specification changes without notice.