



AM-50BAK-(AD)DS

SELF-CONTAINED CUBER WITH BUILT-IN STORAGE BIN



AM-50BAK-(AD)DS
03/11/26
Item # 13204K

Item #: _____
Project: _____
Qty: _____
AIA#: _____

W x D x H
AM-50BAK / AM-50BAK-DS
14⁷/₈" x 22⁵/₈"* x 33¹/₂"
Shipping Dimensions 20³/₄" x 30¹/₂" x 40"
AM-50BAK-AD / AM-50BAK-ADDS
14⁷/₈" x 22⁵/₈"* x 31¹/₂"
Shipping Dimensions 20³/₄" x 30¹/₂" x 38"

(-AD) - ADA Compliant 
(-DS) - Customized Cabinet Door System

* not including handle



AM-50BAK
Air-Cooled
(Shown)
AM-50BAK-AD
Air-Cooled
ADA Compliant Unit



AM-50BAK-DS*
(Shown)
with Custom Cabinetry
AM-50BAK-ADDS*
Air-Cooled
ADA Compliant Unit

*Customer responsible for providing cabinetry



Features

- ▶ Full length stainless steel door handle
- ▶ UL approved for outdoor use
- ▶ Undercounter design
- ▶ Drain pump option available
- ▶ Environmentally friendly R290 hydrocarbon refrigerant

- Up to 54 lbs. of ice production per 24 hours
- Fewer moving parts for longer life
- Power switch accessible without panel removal
- Less than 34 inches tall (AM-50BAK, AM-50BAK-DS)
- Less than 32 inches tall; ADA Compliant (AM-50BAK-AD, AM-50BAK-ADDS)
- Up to 27 lbs. of built-in storage capacity
- Easily disassembled water circuit for easy cleaning
- Front in and out airflow
- Equipped with 6 ft. Cord with NEMA 5-15 Plug

Warranty:

2 Year Parts & Labor on entire machine.
1 Year Parts & Labor on HS-5061 Drain Pump Assembly.
Valid in United States, Canada, Puerto Rico and U.S. Territories. Contact factory for warranty in other countries.

Condenser	Model	ICE PRODUCTION		WATER USAGE		ELECTRICAL				Heat Rejection BTU/hr.	Refrigerant Charge Amount	Net / Ship Weight (lbs.)
		Air / Water Temp Lbs. per 24 hours 70°/50°F 90°/70°F		Potable Gal. per 100 lbs. 90°/70°F	Condenser Gal. per 100 lbs. 90°/70°F	kWh Used per 100 lbs. 90°/70°F	Min. Circuit/Max. Fuse Size	Amperage	Voltage			
Air	AM-50BAK(-DS)	54	35	65.0	N/A	9.0	15A	2.0A	115V/60/1	1,400	2.3oz	103/112
Air	AM-50BAK-AD(-DS)	54	35	65.0	N/A	9.0	15A	2.0A	115V/60/1	1,400	2.3oz	103/112

AM Cube Dimensions*

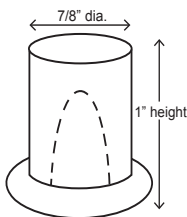

* approximate size in inches, image not to scale

Operating Limits

- Ambient Temp Range 45 - 100°F
- Water Temp Range 45 - 95°F
- Water Pressure 10 - 113 PSIG
- Voltage Range 104-127V
- If GFCI is required, a GFCI breaker MUST be used in lieu of GFCI receptacle

Location

- Allow 15" (38 cm) at front and enough space at rear for water supply and drain connections.
- Location must provide a firm and level foundation.
- Do not place near ovens, grills or other high heat producing equipment.

Parts

- Side trim kit available - HS-0182
- Accessory - HS-5061 Drain Pump Assembly
- Water filter - H9320-51
- 2" Top Spacer Kit - HS-2133

Plumbing

- Icemaker Water Supply Line: Minimum 1/4" Nominal ID Copper Water Tubing or Equivalent
- Icemaker Drain Line: Minimum 1/2" Nominal ID Hard Pipe or Equivalent

Hoshizaki reserves the right to change specifications without notice.



AM-50BAK-(AD)DS

SELF-CONTAINED CUBER WITH BUILT-IN STORAGE BIN

AM-50BAK-(AD)DS

03/11/26

Item # 13204K

FRONT VIEW

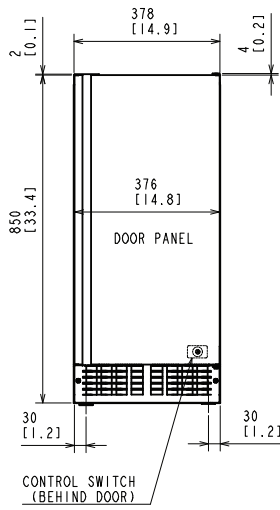

AM-50BAK*

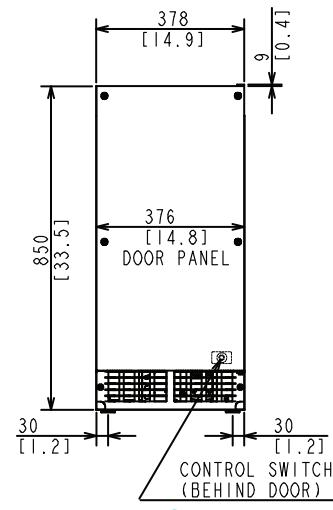

AM-50BAK-DS*

mm
[inch]

* -AD models have height of 31.5"

REAR VIEW

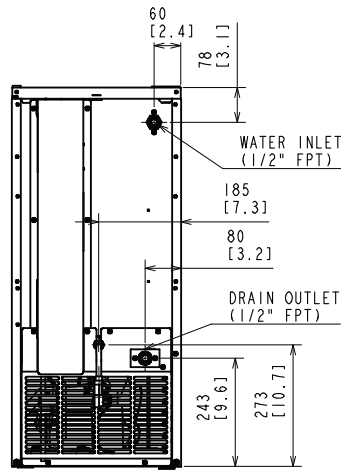

AM-50BAK*

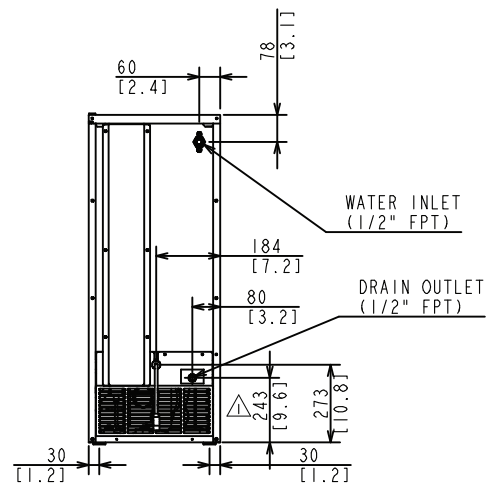

AM-50BAK-DS*

* -AD models have height of 31.5"

SIDE VIEW

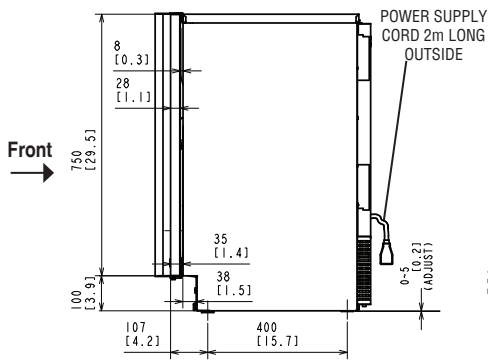

AM-50BAK*

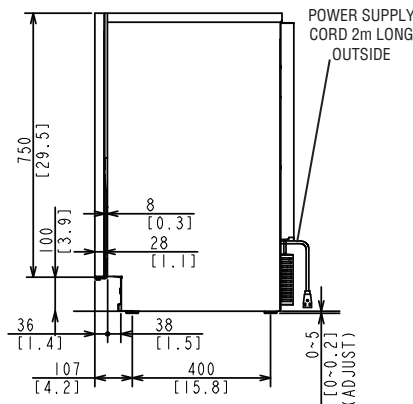

AM-50BAK-DS*

* -AD models have height of 31.5"

TOP VIEW

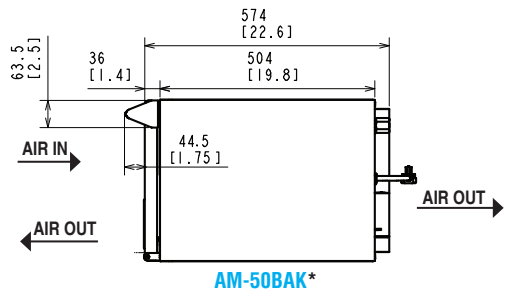

AM-50BAK*

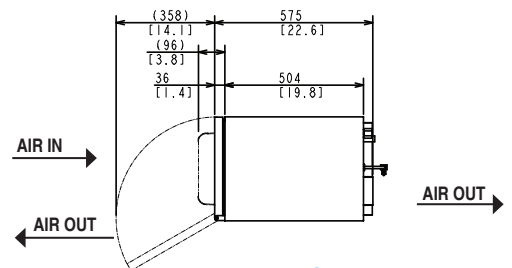

AM-50BAK-DS*