

DISPLAY FREEZER (0°F)

Model: 1FESNGDHD

Natural Refrigerant R-290 Model

1-Section Extra-Wide Display Reach-In Freezer with Half Hinged Glass Door - Shallow Depth

1FESNGDHD - Stainless steel front, aluminum end panels and interior

1FESNSAGDHD - Stainless steel exterior, aluminum interior

1FESNSSGDHD - Stainless steel exterior and interior



Options and Accessories

(upcharge and lead times may apply)

Stainless steel case back	Special electrical requirements (consult factory)
Additional epoxy coated steel shelves	Rehinging of doors (consult factory)
Chrome or stainless steel shelves	Wine rack
Heavy duty pilaster strips	Adjustable legs

Consult factory for other model configurations, options and accessories.

Continental
Refrigerator



Project Name:

Model Specified:

Location:

Item No:

Quantity:

AIA #:

SIS #:

Standard Model Features

REFRIGERATION SYSTEM

Self contained, performance rated refrigeration system

Natural, environmentally safe, high efficiency R-290 refrigerant¹

Automatic, electric condensate evaporator

Expansion valve system

Standard operating temperature is 0 to -5°F and can be adjusted to operate as low as -10°F in a 90°F ambient.

CABINET ARCHITECTURE

3" non-CFC polyurethane foam insulation

Triple-pane, tempered hinged glass doors

Chrome plated door handles

Cam action, lift-off hinges

Self-closing doors

Magnetic snap in door gaskets

Cylinder lock in each door

Heavy duty, epoxy coated steel shelves

5" casters

MODEL FEATURES

LED interior lighting

Electronic control, automatic electric defrost

¹ R-290 refrigerant meets all federal and state regulatory requirements.

APPROVAL:

Model Specifications

DIMENSIONAL DATA

Net Capacity (cubic feet)	18 (510 l)
Width, Overall (inches)	28 1/2 (724 mm)
Depth, Overall (inches) (including handles)	29 1/4 (743 mm)
Depth (inches) (less doors)	25 7/8 (657 mm)
Depth (inches) (doors open 90°)	51 7/8 (1318 mm)
Clear Door Width (inches)	21 7/8 (556 mm)
Clear Half Door Height (inches)	27 1/2 (699 mm)
Height, Overall (inches) (including 5" casters)	82 1/4 (2096 mm)
Number of Doors	2
Number of Shelves	4
Shelf Area (square feet)	20.4 (1.9 sq m)

REFRIGERANT DATA

Condensing Unit Size (H.P.)	1/3
R-290 Refrigerant Charge (oz)	3.6
Capacity (BTU per hour)*	1200

ELECTRICAL DATA

Voltage (International)	115/60/1 (220/50/1)
Feed Wires (including ground)	3
Total Amps (International)	6.5 (3.3)
Defrost Amps (International)	3.9 (2.0)
10 ft. Cord/Plug [attached] (International)	Yes (No)

SHIPPING DATA

Height - Crated (inches)	85 1/2 (2172 mm)
Width - Crated (inches)	31 5/8 (803 mm)
Depth - Crated (inches)	42 (1067 mm)
Volume - Crated (cubic feet)	65 (1841 cu l)
Weight Std - Crated (pounds)	340 (155 kg)
Weight SS - Crated (pounds)	410 (186 kg)

* Rating @ -15°F evaporator, 90°F ambient
Figures in parentheses reflect metric equivalents rounded to the nearest whole unit.

Model Plan Views

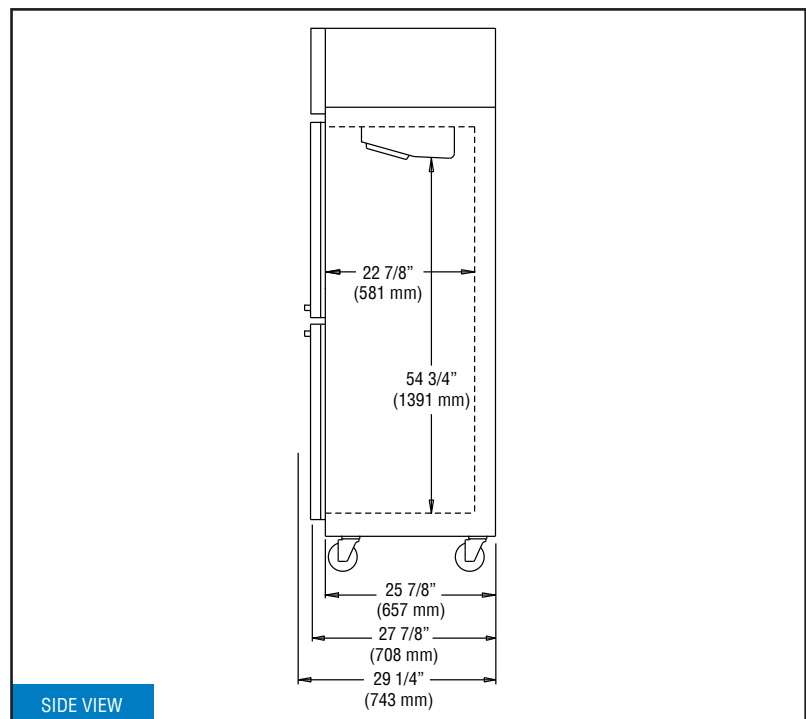
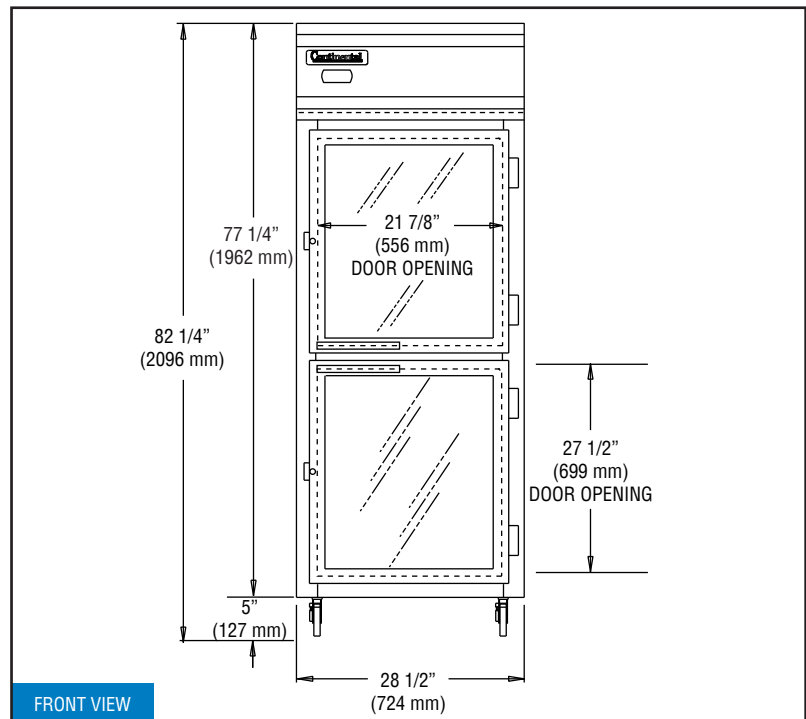

IMPORTANT NOTE: If the cabinet is located directly against a wall and/or under a low ceiling, a minimum clearance of 12" is required on top and 3" on sides and rear.

Continental
Refrigerator

Toll-Free: 800-523-7138
Phone: 215-244-1400
Fax: 215-244-9579

539 Dunksferry Road
Bensalem, PA 19020
www.continentalrefrigerator.com

Due to our continued efforts in developing innovative products, specifications subject to change without notice.



PROUDLY
DESIGNED & ASSEMBLED
IN THE U.S.A.

Intertek

© Copyright 2021. Continental Refrigerator.
A Division of National Refrigeration & Air Conditioning Products, Inc.



Equipped with one NEMA-5-15P Plug
(varies by country)

REVISED: 1/6/26