

BACK BAR EQUIPMENT

Model: BB24N

Natural Refrigerant R-290 Model

24" Back Bar Cooler



ENERGY STAR® Qualified Commercial Refrigerator

Textured baked black enamel finish exterior, stainless steel countertop and interior back with reinforced stainless steel floor.

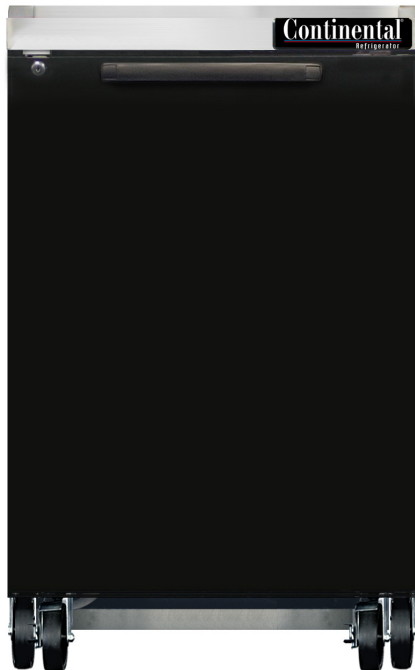

Options and Accessories

(upcharge and lead times may apply)

| | |
|---------------------------------|---|
| Additional epoxy coated shelves | Food storage rated stainless steel interior (NSF-7) |
| Stainless steel shelves | Hinged glass door (consult factory) |
| Wine rack | |

Consult factory for other model configurations, options and accessories.



Project Name:

Model Specified:

Location:

Item No:

Quantity:

AIA #:

SIS #:

Standard Model Features

REFRIGERATION SYSTEM

Performance rated refrigeration system

Natural, environmentally safe, high efficiency R-290 refrigerant¹

Automatic, hot gas condensate evaporator

Extra large, balanced evaporator coil

CABINET ARCHITECTURE

High density, non-CFC polyurethane foamed-in-place insulation

Rear and side venting louvered panels

Magnetic snap in door gasket

Cylinder keyed security lock

Stainless steel reinforced threshold

5" high casters (cannot be changed, footing installed)

MODEL FEATURES

Electronic control, off cycle defrost

Easily accessible and serviceable condensing unit

¹ R-290 refrigerant meets all federal and state regulatory requirements.

APPROVAL:

Model Specifications

DIMENSIONAL DATA

| | |
|---|-------------------|
| Net Capacity (cubic feet) | 8 (226 l) |
| Width, Overall (inches) | 24 1/8 (613 mm) |
| Depth, Overall (inches) (including handle & condenser) | 31 7/16 (798 mm) |
| Height, Overall (inches) | 38 13/16 (986 mm) |
| Bottle/Can Capacity (12 oz) | 55 (per shelf) |
| Number of Doors | 1 |
| Number of Shelves | 2 |

REFRIGERANT DATA

| | |
|-------------------------------|------|
| Condensing Unit Size (H.P.) | 1/5 |
| R-290 Refrigerant Charge (oz) | 2.3 |
| Capacity (BTU per hour)* | 1470 |

ELECTRICAL DATA

| | |
|--|---------------------|
| Voltage (International) | 115/60/1 (220/50/1) |
| Feed Wires (including ground) | 3 |
| Total Amps (International) | 3.2 (1.5) |
| 10 ft. Cord/Plug [attached] (International) | Yes (No) |

SHIPPING DATA

| | |
|--------------------------|--------------|
| Weight (pounds) | 210 (105 kg) |
| Height - Crated (inches) | 45 (1099 mm) |
| Width - Crated (inches) | 31 (908 mm) |
| Depth - Crated (inches) | 36 (946 mm) |

* Rating @ +25°F evaporator, 90°F ambient
 Figures in parentheses reflect metric equivalents rounded to the nearest whole unit.



Equipped with one NEMA-5-15P Plug
 (varies by country)

Continental
 Refrigerator

Toll-Free: 800-523-7138
 Phone: 215-244-1400
 Fax: 215-244-9579

539 Dunksferry Road
 Bensalem, PA 19020
www.continentalrefrigerator.com

Due to our continued efforts in developing innovative products, specifications subject to change without notice.



PROUDLY
 DESIGNED & ASSEMBLED
 IN THE U.S.A.

Intertek

© Copyright 2021. Continental Refrigerator.

Model Plan Views

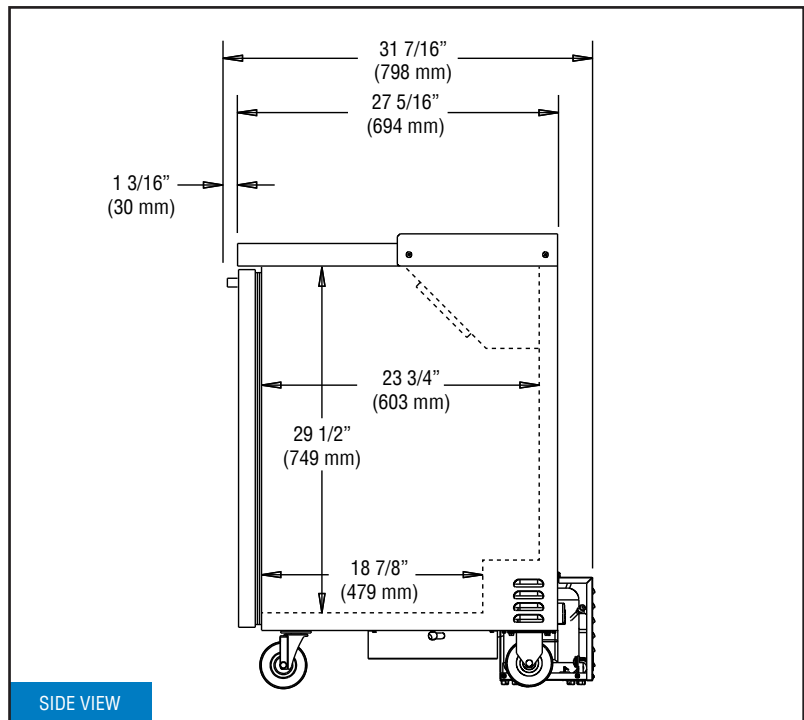
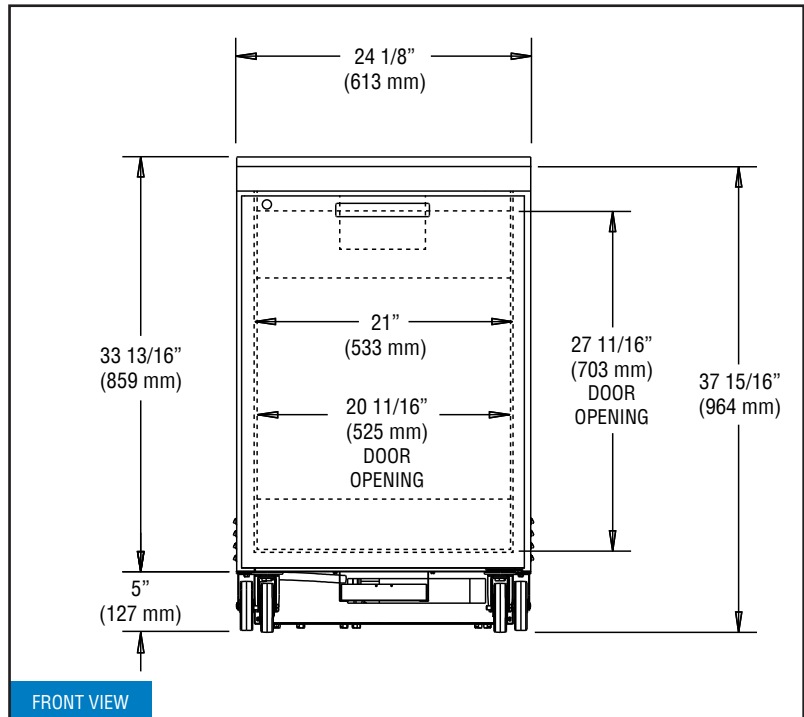

IMPORTANT NOTE: If the cabinet is located directly against a wall, a minimum clearance of 3" is required on sides, front and rear.

REVISED: 4/29/26